



Locality plan

1 : 5000

Site Information:

Address: 26 Rolleston Road Clondeboye
 DP number: LOT 3 DP 75226 LOTS 1-2 DP 73281
 LOT 4 DP 61673 RS 38157 LOT 1 DP
 81114 SEC 1 SO 19658 SEC 1 SO
 20203 LOT 1 DP 450527 SEC 2
 CLONDEBOYE NO 2 SETT
 Exposure Zone: Zone B
 Earthquake Zone: Zone 1
 Wind Zone: High

DLA Drawing Index			
Sheet Number	Sheet Name	90% Review 30/07/24	Tender Issue 29/08/24
A0.00	Drawing Schedule & Location Plan	0	1
A0.10	Standard Notation & Project Specific Notes	0	1
A0.20	Project Key Notes	0	1
A1.00	Locality Plan	0	1
A1.02	Site Plan Control Room - Boilers 1 & 2	0	1
A1.03	Site Plan Control Room - Boilers 4,5 & 6	0	1
A2.00	Existing and Demo Control Room Floor Plans - Boilers 1 & 2	0	1
A2.01	Existing and Demo Control Room Boilers 4,5 & 6	0	1
A2.02	Proposed Control Room Floor Plan - Boilers 1&2	0	1
A2.03	Proposed Control Room Floor Plan - Boilers 4,5&6	0	1
A2.10	Plumbing and Drainage Plan Control Room - Boilers 1&2	0	1
A2.11	Plumbing and Drainage Plan Control Room - Boilers 4,5 & 6	0	1
A2.20	Electrical and Fire Safety Plan Control Room - Boilers 1&2	0	1
A2.21	Electrical and Fire Safety Plan Control Room - Boilers 4,5&6	0	1
A2.30	Reflected Ceiling / Lighting Plan Control Room - Boilers 1&2	0	1
A2.31	Reflected Ceiling / Lighting Plan Control Room - Boilers 4,5&6	0	1
A2.40	Bracing Plan Control Room - Boilers 1&2	0	1
A2.41	Bracing Plan Control Room - Boilers 1&2 Bracing Calculation	0	1
A2.50	Proposed Control Room Roof Plan - Boilers 1&2	0	1
A2.51	Proposed Control Room Roof Plan - Boilers 4,5&6	0	1
A2.60	Proposed Foundation Plan Control Room - Boilers 1 & 2	0	1
A2.61	Proposed Foundation Plan Control Room - Boilers 4, 5 & 6	0	1
A3.00	Wall & Floor Finishes Plan Control Room - Boilers 1&2	0	1
A3.01	Wall & Floor Finishes Plan Control Room - Boilers 4,5 & 6	0	1
A4.00	Control Room - Boilers 1&2 Elevations North & South	0	1
A4.01	Control Room - Boilers 1&2 Elevations West & East	0	1
A4.02	Control Room - Boilers 4,5&6 Elevations	0	1
A5.00	Control Room - Boilers 1&2 Section A & B	0	1
A5.01	Control Room - Boilers 1&2 Section C	0	1
A5.02	Control Room - Boilers 4,5 & 6 Sections E & F	0	1
A5.03	Control Room - Boilers 4,5 & 6 Section G	0	1
A6.01	Joinery Location Plan	0	1
A6.02	Boilers 1&2 Control Room Enlarged Plan - Office	0	1
A6.03	Boilers 1 & 2 Control Room - Office Elevation 1	0	1
A6.04	Boilers 1 & 2 Control Room - Office Elevation 2	0	1
A6.05	Boilers 1&2 Control Room Enlarged Plan - Permits	0	1
A6.06	Boilers 1 & 2 Control Room - Permits Elevation 1	0	1
A6.07	Boilers 1 & 2 Control Room - Permits Elevation 2	0	1
A6.08	Boilers 1 & 2 Control Room - Lab Elevation	0	1
A6.09	Boilers 1 & 2 Control Room Enlarged Plan - Acc Toilet and Wc.	0	1
A6.10	Boilers 1 & 2 Control Room - Acc Toilet Elevation	0	1

DLA Drawing Index			
Sheet Number	Sheet Name	90% Review 30/07/24	Tender Issue 29/08/24
A6.11	Boilers 1 & 2 Control Room - Wc. Elevation	0	1
A6.12	Boilers 1 & 2 Control Room Enlarged Plan - Control Room	0	1
A6.13	Boilers 1 & 2 Control Room - Control room Elevation 1	0	1
A6.14	Boilers 1 & 2 Control Room - Control room Elevation 2	0	1
A6.15	Boilers 1 & 2 Control Room - Document Storage Elevation	0	1
A6.16	Boilers 4, 5 & 6 Control Room Enlarged Plan - cl. and Sh. & Wc.	0	1
A6.17	Boilers 4, 5 & 6 Control Room - cl. and Sh. & Wc. Elevation	0	1
A6.18	Boilers 4, 5 & 6 Control Room Enlarged Plan - Female Lockers	0	1
A6.19	Boilers 4, 5 & 6 Control Room - Female Lockers Elevation	0	1
A6.20	Boilers 4, 5 & 6 Control Room Enlarged Plan - Male Lockers	0	1
A6.21	Boilers 4, 5 & 6 Control Room Enlarged Plan - Male Lockers Elevation A	0	1
A6.22	Boilers 4, 5 & 6 Control Room Enlarged Plan - Male Lockers Elevation B	0	1
A6.23	Boilers 4, 5 & 6 Control Room - Lunch Room Elevation	0	1
A7.00	Exterior Window Schedule Control Room Boilers - 1 & 2	0	1
A7.01	Exterior Window Schedule Control Room Boilers - 4, 5 & 6	0	1
A7.10	Door Schedule Control Room Boilers - 1 & 2	0	1
A7.11	Door Schedule Control Room Boilers - 4, 5 & 6	0	1
A8.00	Timber Post Concrete Footing Detail	0	1
A8.01	Foundation Join With Wall Detail	0	1
A8.02	Foundation Detail	0	1
A8.03	Foundation With 90 Nib Detail	0	1
A8.04	Roof and Ceiling Detail 1	0	1
A8.05	Foundation and nib connect with existing	0	1
A8.06	Cap & Apron Flashing Detail	0	1
A8.07	Roof With Eaves	0	1
A8.08	Varanda Rafter Join With Wall	0	1
A8.09	Varanda Detail 1	0	1
A8.10	Varanda Detail 2	0	1
A8.11	Gutter Detail With No Eaves	0	1
A8.12	Internal Beam Detail	0	1
A8.13	Eco Open Channel Drain Detail	0	1
A8.21	Exterior Door Open In Detail	0	1
A8.22	Exterior Sliding Door Detail	0	1
A8.23	Exterior Window Details	0	1
A8.24	Exterior Nib To Vinyl Detail	0	1
A8.30	Wall Junction Detail	0	1
A8.31	Wall Junction Detail Join With Existing Structure	0	1
A8.32	GIB Horizontal Detail	0	1
A8.33	Boiler 4, 5 & 6 Control Room Roof Join With Existin	0	1
A8.34	Boiler 1 & 2 Control Room Roof Join	0	1
A8.35	HWC and Pipe Penetration	0	1
A8.36	Bedding and backfilling	0	1
A8.40	Interior Vinyl Detail	0	1
A8.41	Interior Corner Detail	0	1
A9.01	Joinery Detail - Benchtop for office and control room	0	1
A9.02	Joinery Detail - Permits Detail	0	1
A9.03	Joinery Detail - Lab And Locker Detail	0	1
A9.04	Interior Door Details 1	0	1
A9.05	Interior Door with Raven Seal	0	1
A9.06	Interior Door Cavity Slider	0	1



Copyright: The copyright of this drawings remains the property of DLA Architects Limited and may only be used or re-used with DLA's prior written consent.

Project: Clondeboye Bio Mass Control Room & Amenities



Drawing Title: Drawing Schedule & Location Plan
 CAD File:

REV.	DATE	REVISION DETAILS
1	28/08/24	Tender Issue
0	27/05/24	First Issue

Scale: As indicated @ A3
 Date: 29/08/24
 Drawn: MX
 Designed: MA
 Checked: CG
 Job No: C919
 Drawing No: A0.00
 Revision No: 1

General Notes:

- The Architectural drawings shall be read in conjunction with the associated specifications and conditions of contract. The drawings shall also be read in conjunction with all Structural, Services, & Civil documentation, and all other project drawings. Any discrepancies shall be referred to the Architect for resolution.
- Do not scale from these drawings, use figured dimensions only. Verify all dimensions with Structural, Services, Civil and all other project drawings prior to construction commencing. Refer all discrepancies to the Architect for resolution.
- Substitution for, or amendment to the specified details or materials shall not be carried out without prior approval of the Architect.
- All work shall be carried out strictly in accordance with the New Zealand Building Code, Local Territorial Authority Requirements, OSH Requirements & Regulations, and any other Statutory Requirements that may be applicable to this project.
- All work shall be of best trade practice.

Abbreviations:

AD	Above Datum	MS	Mild Steel
AP	Access Panel	MAX	Maximum
APPR	Approved	MIN	Minimum
BM	Benchmark	MM	Millimetre
		M	Metre
C/C	Centre to Centre	NB	Nominal Bore
CL	Centre Line	NTS	Not to Scale
CTRS	Centres	NZS	New Zealand Standard
CODE	Building Code	O/A	Overall
CONC	Concrete	O/H	Overhead
COS	Check on Site	OD	Outside Diameter
CORR	Corrugated	O/F	Overflow
CB	Coach Bolt	PC	Precast Concrete
CS	Coach Screw	PFC	Parallel Flange Channel
CSK	Countersunk	R	Radius
CHS	Circular Hollow Section	RAD	Radiata
CJ	Construction Joint	RHS	Rectangular Hollow Section
CP	Cesspit	REF	Reference
DRG	Drawing	RC	Reinforced Concrete
DWG	Drawing	ROW	Right of Way
DIA	Diameter	RL	Reduced Level
DIAG	Diagonal	RO	Rough Opening (refer to detail)
DHS	Dimond Hi-Span (metal Purlin)	SC	Sawcut Joint
DIM	Dimension	S.S	Stainless Steel
DPC	Damp Proof Course	S.S.S	Satin Stainless Steel
DPM	Damp Proof Membrane	SED	Small End diameter
DB	Distribution Board	SK	Sketch
DP	Downpipe	SPEC	Specification
D4S	Dressed Four Sides	SHT	Sheet
EJ	Expansion Joint	SCHED	Schedule
FHR	Fire Hose Reel	SHS	Square Hollow Section
FG	Fixed Glass	SP	Soil Pipe
GT	Gully Trap	SQ/M	Square Metre
HD	Hold Down Bolt	TFC	Tapered Flange Channel
HDG	Hot Dipped Galvanised	TYP	Typical
HOR	Horizontal	TGV	Tongue, Groove & Vee Joint
ID	Inside Diameter	TV	Terminal Vent
IL	Invert Level	U/S	Underside
IB	Inspection Bend	UB	Universal Beam
IJ	Inspection Junction	UC	Universal Column
KW	Kilowatt	VER	Vertical
L	Litre	W	Watt
		WT	Wall Thickness

Drawing Annotation:

Drawing Numbering

A2.05	A	Discipline (i.e A is for Architect)
	2	Series (100, 200, 300 etc)
	05	Sheet Number (0-99)

Series Numbering

A0.00	Drawing Schedule, Locality Plan, General Notation
A1.00	Site Drawings
A2.00	Plans
A3.00	Finishes Plans
A4.00	Elevations
A5.00	Cross Sections
A6.00	Enlarged Plans / Room Elevations
A7.00	Door & Window Schedules
A8.00	Construction Details
A9.00	Interior Details

Doors and Windows

Refer to floor plans & door & window schedules for rough opening sizes, finishes, hardware & furniture.

Door Numbers

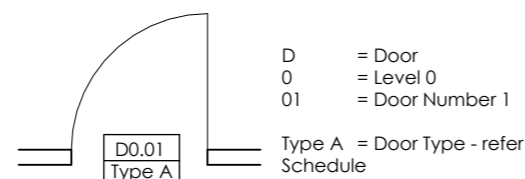

Window Numbers

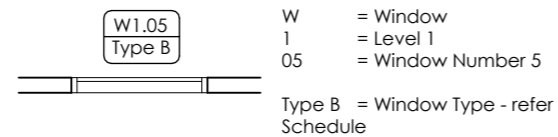

Space Numbering

1.03	1	= Level Number
Kitchen	03	= Space Number
	Kitchen	= Space Name

Wall Finishes Type Keys

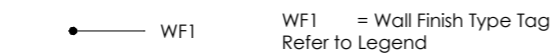

Floor Finishes Type Keys



Ceiling Finishes Type Keys

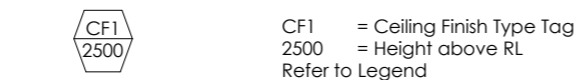

Reference Symbols:

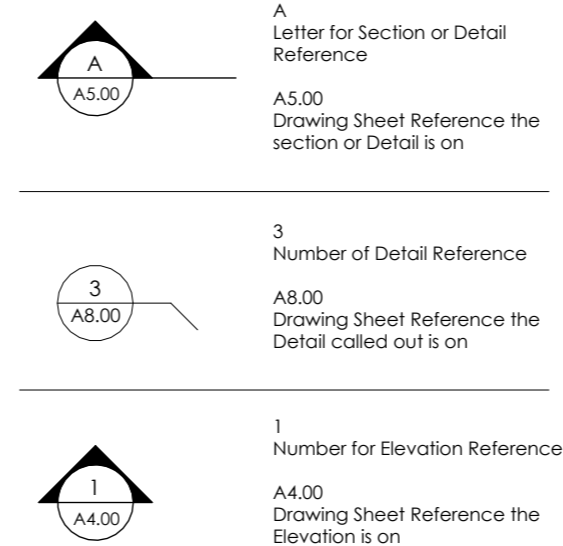

Expression of Levels:

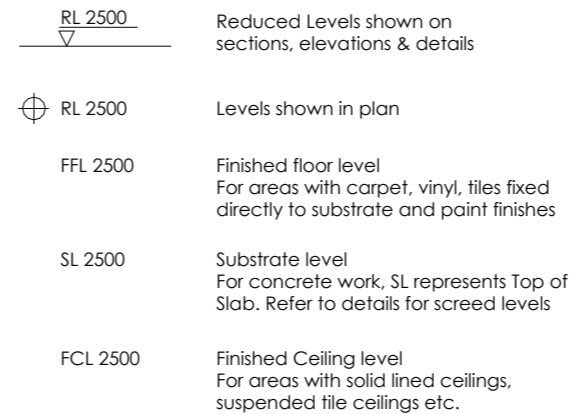

North Arrows:

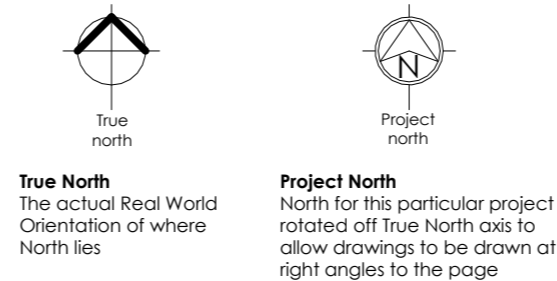

Keynote Tags:

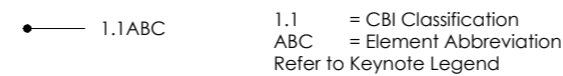

Project Specific Notes:

Client Supply Items:
Lockers to be supplied by client
Items for Salvage:

Copyright:

The copyright of this drawings remains the property of DLA Architects Limited and may only be used or re-used with DLA's prior written consent.

Project:

Clandeboyne Bio Mass Control
Room & Amenities

Client:

Fonterra
Clandeboyne



Drawing Title:

Standard Notation & Project
Specific Notes

CAD File:

1	28/08/24	Tender Issue
0	27/05/24	First Issue
REV.	DATE	REVISION DETAILS

Scale:

1 : 50 @ A3

Date:

29/08/24

Drawn:

MX

Designed:

MA

Checked:

CG

Job No:

C919

Drawing No:

A0.10

Revision No:

1

Keynote Legend

Key Value	Keynote Text
31.ASG	ANCHOR SCREW: anchor screw M6 30x30x3mm galvanized washer.
31.BM12	M12: fix beam with M12 bolts and 50x50x3mm galvanized washer.
31.CSS	25mm T head stainless steel brad nails for panel fixing.
31.FAS	12mm hdg cast-in anchor + 50x50x3mm galvanized washer@ max. 900ctrs - 66mm min. from concrete edge. Position a 'Fixing Anchor' within 150mm of the end of each plate or any wall bracing element.
31.GSN	NAIL: galvanized steel nail.
31.JHR	S.S. Lumberlok JH47 x 120 joist hanger. Fix with Product Nails 30mm x 3.15dia. per flange or 2/Type 17-12g x 35mm Hex Head Screws.
31.M12	M12 Bolt.
31.RDN	65x2.8mm Round Drive ring shank nails for batten fixing
31.RIV	RIVET: Aluminium standard rivets.
31.SFN	SCREW: min. 12 gauge screw fixing w/ neoprene washer over EPDM washer where required to allow for expansion. 6T3 - Hit 2, Miss 2, Hit 1. 75mm nail.
31.WBE	WATERBAR: Waterbar epoxied into sawcut.
32.A10	R10 @ 600ctrs vertically
32.BAR	BAR: 2/D12 Bar horizontal.
32.COS	Waterproof concrete when dry with concrete sealer.
32.FSE	FOOTING: Concrete footing 200mm wide down to good ground. 140mm width, 150mm height nib with scabble to slab, d10 starters @ 600crs, D10 running length of nib.
32.FST	FOOTING: Concrete footing 200mm wide down to good ground. 90mm width, 150mm height nib with scabble to slab, d10 starters @ 600crs, D10 running length of nib.
32.MES	MESH: 500E grade mesh with 30mm min. top cover.
32.PSL	Proposed paving slab.
32.RE10	REBAR: D10 rebar @400crs. supplementary reinforcing bars required at internal corner, 2 x D10, 1200m long. 50mm below slab surface to clear reinforcing.
32.REB	REBAR: D12 rebar @400crs.50mm below slab surface to clear reinforcing. lap 400 within slab mesh. 150mm epoxy-fixed into existing slab.
32.SLB	SLAB ON GROUND: 100mm thick 20mpa concrete slab reinforced with SE62 500E grade mesh over 250 micron polythene DPM.
32.SOG	SLAB ON GROUND: 100mm thick 20mpa concrete slab reinforced with SE62 500E grade mesh over 250 micron polythene DPM.- 30mm top cover. Place concrete over 250micron polythene DPM fully lapped and sealed at all junctions in accordance with NZS3604. Protect DPM with a maximum of 25mm sand blinding on 150mm min compacted hardfill. Starter to overlap mesh by 400mm min. Mesh shall be lapped in accordance with the manufacturers specification, or a minimum of 1 square plus 50mm (as minimum requirement under nzs 3101). 5mm deep sawcuts at 6m crs and perimeter foundations.
33.ETF	EXTERNAL TIMBER NOGGING
37.ETB	BEAM: 150 x 45mm timber beam.
37.ETS	STRINGER: 90 x 45mm timber stringer.
37.ETT	STRINGER: 140 x 45mm timber stringer.
37.TBC	BEAD: timber bead cut to suit.
38.ETE	EXTERNAL TIMBER FRAMING EXISTING: 90 x 45mm, H1.2 treated timber wall framing remain unchanged.
38.ETF1	EXTERNAL TIMBER FRAMING: 140 x 45mm, H1.2 studs at 600mm centres max.
38.ETF2	EXTERNAL TIMBER FRAMING: Construct with 90 x 45mm, H1.2 studs at 600mm centres max.
38.IJF	Jack framing. 90 x 45 @ 600 crs. dwangs 800crs max.
38.ITF	INTERNAL TIMBER FRAMING: Construct with 90mm x 45mm SG8 h1.2 framing with studs @ 600mm crs to nzs3604:2011. Dwang at 800mmcrs. Dwang for all fittings, fixtures, linings, bracing panels & trims. DPC between bottom plate and conc. Slab.
38.RTP	TIMBER PURLINS: 70x45mm SG8 H1.2 treated timber purlins with 900mm spacing, max fixed with 1/10g Self-drilling screw, 80mm long, at each rafter/truss.
38.TC3	H3.1 timber cavity battens 20mm.
38.TDL	LINTEL: lintel refer to truss and lintel design schedule.
38.TLT	LINTEL: 240 x 90mm LVL Futurebuild H1.2 Lintel. Fix to wall framing with MiTek Lumberlok Lintel Fixing TYPE H.
38.TP1	TIMBER POST: Prolam 88x88mm, H5 Visual (PLPH5-100) post with 3 coat paint finish, footing size refer to detail drawing.
38.TPP	TIMBER PACKER PITCH: H3.2 timber packer shaped to suit 5deg. pitch.
38.TPQ	TIMBER PACKER PITCH: H1.2 timber packer shaped to suit 8deg. pitch.
38.ITC	TIMBER TRUSS CONSTRUCTION: Timber trusses @ 900 crs generally designed, fabricated and fixed according to the engineered truss design and specifications.
38.TTP	TIMBER PACKER.
38.TTT	TIMBER TRUSS: timber end truss to take cladding.
39.TVB	BENCH: 70 x 45mm timber frame for Vinyl Bench.
39.WTP	25mm H3.1 pre-primed, pine timber, flush reveals with enamel painted finish.
42.AXO	AXON Panel: 9mm thick x 1200mm wide Axon Panel, over CLD cavity battens fixed to wall framing, over RAB board to new timber wall framing. To be installed in accordance with Axon Panel Technical Specification. Coat paint finish to match existing cladding, unless noted otherwise.
42.CCL	CAVITY CLOSER: Cavity closure strip Hardie uPVC vent strip 75mm min upstand with 1000mm2 of opening per lineal metre. Keep clear of debris.
42.EXC	Existing cladding.
42.SCB	CAVITY BATTEN: 70 x 19mm Hardie CLD Structural Cavity Batten installed in 20mm drained cavity fixing.
43.DPC	DPC to provide separation of metal capping and timber.
43.FFT	ROOF FLASHING: flexible flashing tape to seal off roof space from cladding cavity.
43.FSR	ROOFING: Freeman Six Rib Roofing 0.55 BMT Colorcote MagnaFlow pre-finished steel trapezoidal roofing. Colour match the existing.
43.FVC	foam vented cavity closure strip.
43.JHS	JAMES HARDIE SOFFIT LINING: 6mm prefinished Villaboard Eaves soffit lining and pvc jointers with painted finish
43.PBP	Building Paper under Axon Panel.
43.PCF	CAP FLASHING: 0.55BMT Colorcote MagnaFlow pre-finished parapet cap flashing
43.PEF	EAVE FLASHING: 0.55 BMT pre-finished eave flashing.

Keynote Legend

Key Value	Keynote Text
43.RUL	UNDERLAY: Thermakraft Covertek 407 roof underlay
43.SEA	BRANZ approved flexible sealant.
43.SEAC	Edge to be sealed before fixing typical 2mm maximum gap.
43.TAF	TYPICAL APRON FLASHING: 0.55mm BMT Colorcote MagnaFlow apron flashings complete with hem. 75mm min. cover to over flashing, 110mm total height. over flashing w/ 35mm min. clearance to apron flashing. refer to cladding notes for material type.
43.TBF	TYPICAL METAL BARGE FLASHING: 0.55 BMT Colorcote MagnaFlow (matching colour as roof cladding) Barge flashing lapped over roof cladding, lap min. 2 crests.
43.TFA	TYPICAL FASCIA/BARGE BOARD 185mm: 0.55BMT Colorcote MagnaFlow formed steel fascia with clips fixed to framing. Colorcote MagnaFlow gutters packed off fascia with 6mm gap behind.
43.TFB	TYPICAL METAL FASCIA/BARGE BOARD 147mm: 0.55BMT Colorcote MagnaFlow formed steel fascia with clips fixed to framing. Colorcote MagnaFlow gutters packed off fascia with 6mm gap behind.
43.TGU	TYPICAL GUTTER: Colorcote MagnaFlow steel 125mm Box gutter with external brackets and snow straps @ 500crs fixed in accordance with manufacturers recommendations and colour matched to roofing.
43.THF	TYPICAL HEAD FLASHING: 0.55mm BMT Colorcote MagnaFlow head flashings. 70mm min. cover to over flashing.
43.TRF	TYPICAL RIDGE FLASHING: 0.55mm BMT Colorcote MagnaFlow ridge flashings complete with control/slip joint.
45.WAS	WINDOW AIR SEAL: flexible wet sealant over PEF backing rod.
45.WFT	55: Selected window flashing tape - refer specification
46.CST	75mm wide sealing tape.
46.JHC	Hardie 9mm aluminium internal corner.
46.JHEC	Hardie 9mm Panel Aluminium External Box Corner.
47.INR	Pink Batts Roof insulation 275mm.
47.INW	Pink Batts wall insulation 90mm.
47.RAB	Rigid Air Barrier: James Hardie RAB Board 6mm.
47.SNF	SEAL: apply continuous 6mm bead of Seal n Flex-1 or Sikaflex 11FC adhesive sealant.
51.ARC	ARCHITRAVE: 60x18mm timber architrave with enamel painted finish
51.EIL	Existing wall lining.
51.HGA	13mm GIB Aqualine interior wall lining, level 4 plaster and paint finish
51.HGL	13mm GIB Standard interior wall lining, level 4 plaster and paint finish
51.HGP	New paint finish over existing lining.
51.QGL	GBTLA 45r Double 13mm GIB Standard interior wall lining, level 4 plaster and paint finish.
51.SHL	Acrylic liner over unsealed GIB Aqualine.
52.BAR	BAG RACK
52.EPW	FINISH: existing plywood finish remain unchanged.
52.PWF	FINISH: proposed plywood finish align with existing.
52.SSO	SOCKET: Switched socket outlets.
52.TPI	PACKER: Timber packer over DPC.
53.GBL	GIB BOARD CEILING LINING: 13mm Aqualine GIB board ceiling lining, level 4 GIB stopping and 3 coat paint finish, supported by rondo suspended ceiling grid system. Refer to Colour Schedule.
53.GCL	GIB BOARD CEILING LINING: 13mm Standary GIB board ceiling lining, level 4 GIB stopping and 3 coat paint finish, supported by rondo suspended ceiling grid system. Refer to Colour Schedule.
53.GCL2	Double GIB Quiet ceiling.
53.RQC	RONDO QUIET CLIP fixed to truss bottom chords
53.RQT	Rondo track 310mm.
53.SCT	SUSPENDED CEILING TILES: 1200 x 600 x 16mm Armstrong Fine Fissured RH99, NRC0.60 CAC35 acoustic ceiling, square lay-in a 2-way Armstrong 24mm Peakform suspended grid system. Refer to Colour Schedule.
53.SFC	Standard Fiber Cement sheet fix onto existing ceiling grid.
55.AWF	FLASHING TAPE: Thermakraft Theraflash flashing tape to run perimeter of opening, lap 50mm minimum over wall underlay/RAB
55.FBB	Foam bond breaker.
55.SAF	SIKAFLEX SEALANT: continuous Sikaflex AT-Facade waterproof sealant / airseal over PEF rod to perimeter of trim cavity.
55.SSB	SUPPORT BAR: Sill support bar, pre-fill fixing holes with silicon sealant.
55.STP	SILL TIMBER PACKER: 25mm H3.2 treated timber reveal, 3 coat.
55.TUP	Turn-up flashing tape 100mm min. at trimmer studs.
55.WANZ	WANZ sill support bar.
64.VS2	VINYL SURFACING 02: 2mm thick Jacobsens Tarkett Primo Premium commercial grade floor vinyl glued and fixed in accordance with the manufacturers specification, covered 150mm unless stated otherwise. Welded joints. Refer to Colour Schedule.
64.VS3	VINYL SURFACING 03: 2mm thick Jacobsens Tarkett Primo Safe.T NON-SLIP commercial grade floor vinyl glued and fixed in accordance with the manufacturers specification, covered 150mm unless stated otherwise. Welded Joints. Refer to Colour Schedule.
73.ACW	Accessible Toilet: Adesso Elevate Back to Wall Toilet Suite with Soft Close
73.MRR	Mirror: Custom Mirox Polished Edge Mirror No Fixings @ 450 x 850mm.
73.SDU	Sanitary Disposal Unit.
73.SHR	Cubicle shower unit.
73.SSD1	Soap Dispensers: Mediclinics Surface Push-Button Liquid Soap Dispenser - Matte Black Epoxy
73.SSD2	Shower Soap Dispensers: Mediclinics Surface Push-Button Liquid Soap Dispenser - Matte Black Epoxy
73.TDP	Paper Towel dispensers.
73.TRH	Toilet Paper Holder.
73.WC	Toilet: Adesso Elevate Back to Wall Toilet Suite with Soft Close Seat Raised Button Set.
73.WHB	Accessible Wall Basin: Basin: Johnson Suisse Quado 450 Wall Hung Basin with Quado Shroud
74.DCR	REINFORCEMENT: Drainage corner reinforcement to waterproofing membrane change of substrate in accordance with manufacturers details.
74.DP1	DOWNPIPES: 80dia. Colorcote MagnaFlow downpipes with pipe brackets @ 1200crs and maintenance gap to riser with leaf grate
74.GEB	BRACKET: External Gutter bracket spacings 750mm.
74.LAW	Liquid applied waterproofing (UV stable) to channel and face of slab.
74.MDR	MEMBRANE: Membrane dressed into reveal.

General Notes:

- This drawing shall be read in conjunction with all other drawings & specifications.
- All work shall be strictly in accordance with the New Zealand Building Code, Local Territorial Authority Requirements, OSH Requirements & Regulations, and any other Statutory Requirements that may be applicable to this project.
- All work shall be of best trade practice.
- Do not scale from this drawing. Use only figured dimensions. The Contractor shall verify all dimensions on site, and report any discrepancies to the Architect before commencing work.



Copyright:
The copyright of this drawings remains the property of DLA Architects Limited and may only be used or re-used with DLA's prior written consent.

Project:
Clandeboye Bio Mass Control Room & Amenities



Drawing Title:
Project Key Notes
CAD File:

REV.	DATE	REVISION DETAILS
1	28/08/24	Tender Issue
0	27/05/24	First Issue

Scale: @ A3	Date: 29/08/24	Drawn: MX
	Designed: MA	Checked: CG
Job No: C919	Drawing No: A0.20	Revision No: 1

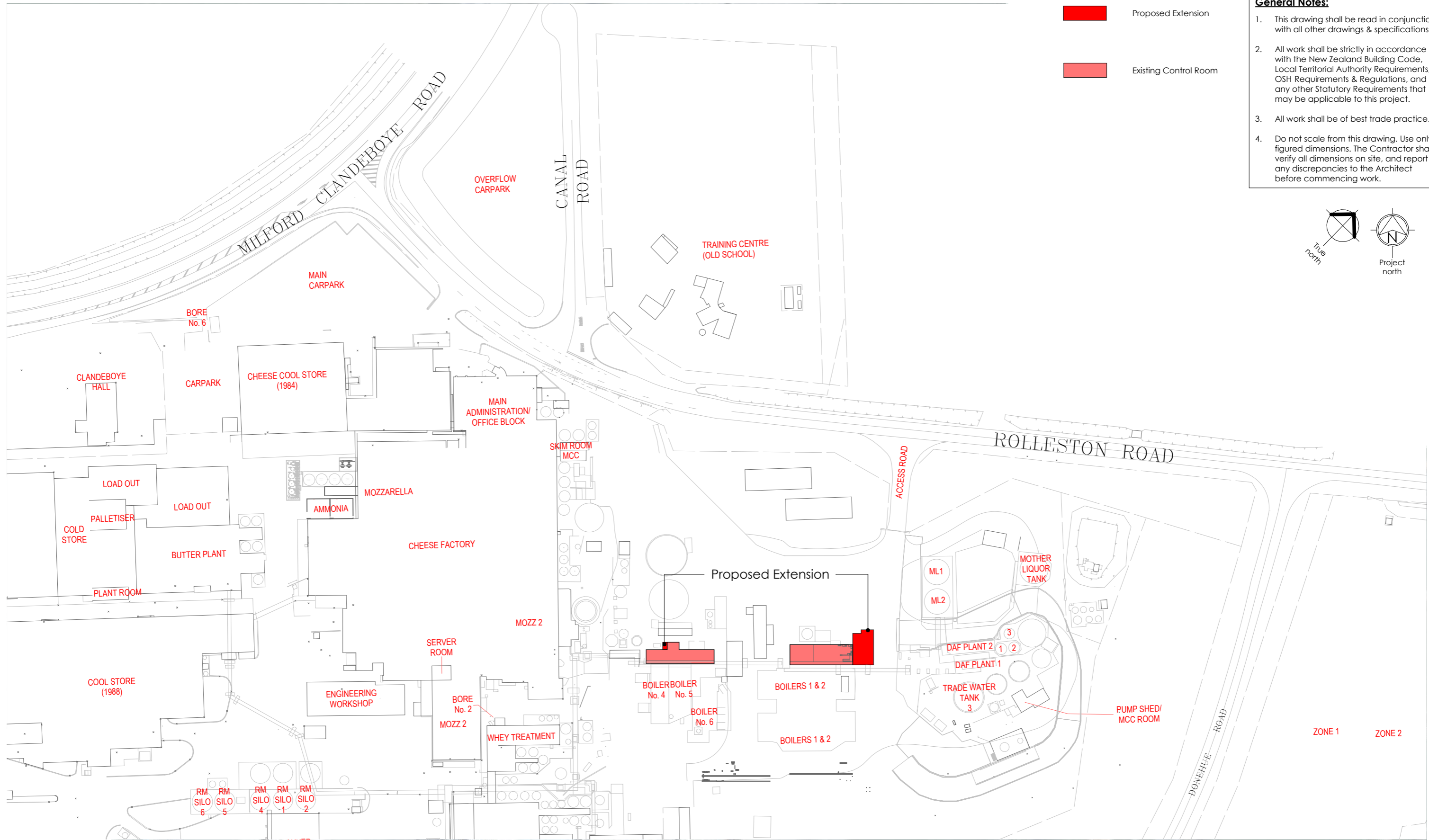

- Proposed Extension
- Existing Control Room

- General Notes:**
1. This drawing shall be read in conjunction with all other drawings & specifications.
 2. All work shall be strictly in accordance with the New Zealand Building Code, Local Territorial Authority Requirements, OSH Requirements & Regulations, and any other Statutory Requirements that may be applicable to this project.
 3. All work shall be of best trade practice.
 4. Do not scale from this drawing. Use only figured dimensions. The Contractor shall verify all dimensions on site, and report any discrepancies to the Architect before commencing work.

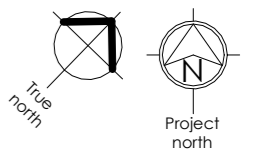

Locality Plan 1 to 1500

1 : 1500



Copyright:
 The copyright of this drawings remains the property of DLA Architects Limited and may only be used or re-used with DLA's prior written consent.

Project:
Clandeboye Bio Mass Control Room & Amenities

Client:
Fonterra Clondeboye

Drawing Title:
Locality Plan
 CAD File:

REV.	DATE	REVISION DETAILS
1	28/08/24	Tender Issue
0	27/05/24	First Issue

Scale: As indicated @ A3	Date: 29/08/24	Drawn: MX
Job No: C919	Designed: MA	Checked: CG
Drawing No: A1.00	Revision No: 1	

- General Notes:**
1. This drawing shall be read in conjunction with all other drawings & specifications.
 2. All work shall be strictly in accordance with the New Zealand Building Code, Local Territorial Authority Requirements, OSH Requirements & Regulations, and any other Statutory Requirements that may be applicable to this project.
 3. All work shall be of best trade practice.
 4. Do not scale from this drawing. Use only figured dimensions. The Contractor shall verify all dimensions on site, and report any discrepancies to the Architect before commencing work.

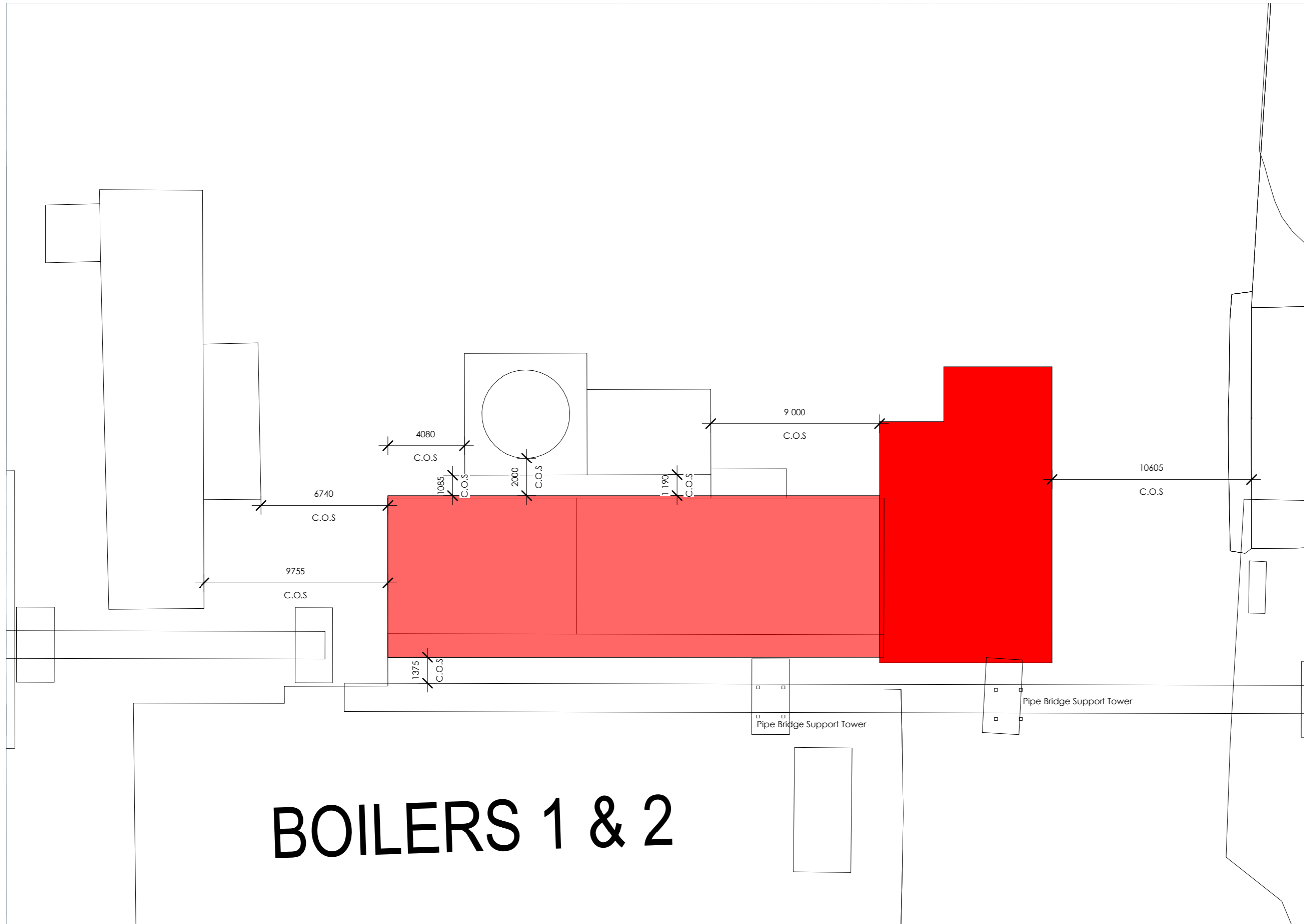
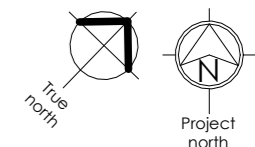

BOILERS 1 & 2

- Proposed Extension
- Existing Control Room

Site Plan Control Room - Boilers 1 & 2

1 : 200



Copyright:
The copyright of this drawings remains the property of DLA Architects Limited and may only be used or re-used with DLA's prior written consent.

Project:
Clandeboye Bio Mass Control Room & Amenities

Client:
Fonterra Clandeboye

Drawing Title:
Site Plan Control Room - Boilers 1 & 2
CAD File:

REV.	DATE	REVISION DETAILS
1	28/08/24	Tender Issue
0	27/05/24	First Issue

Scale: As indicated @ A3	Date: 29/08/24	Drawn: MX
Job No: C919	Designed: MA	Checked: CG
Drawing No: A1.02	Revision No: 1	

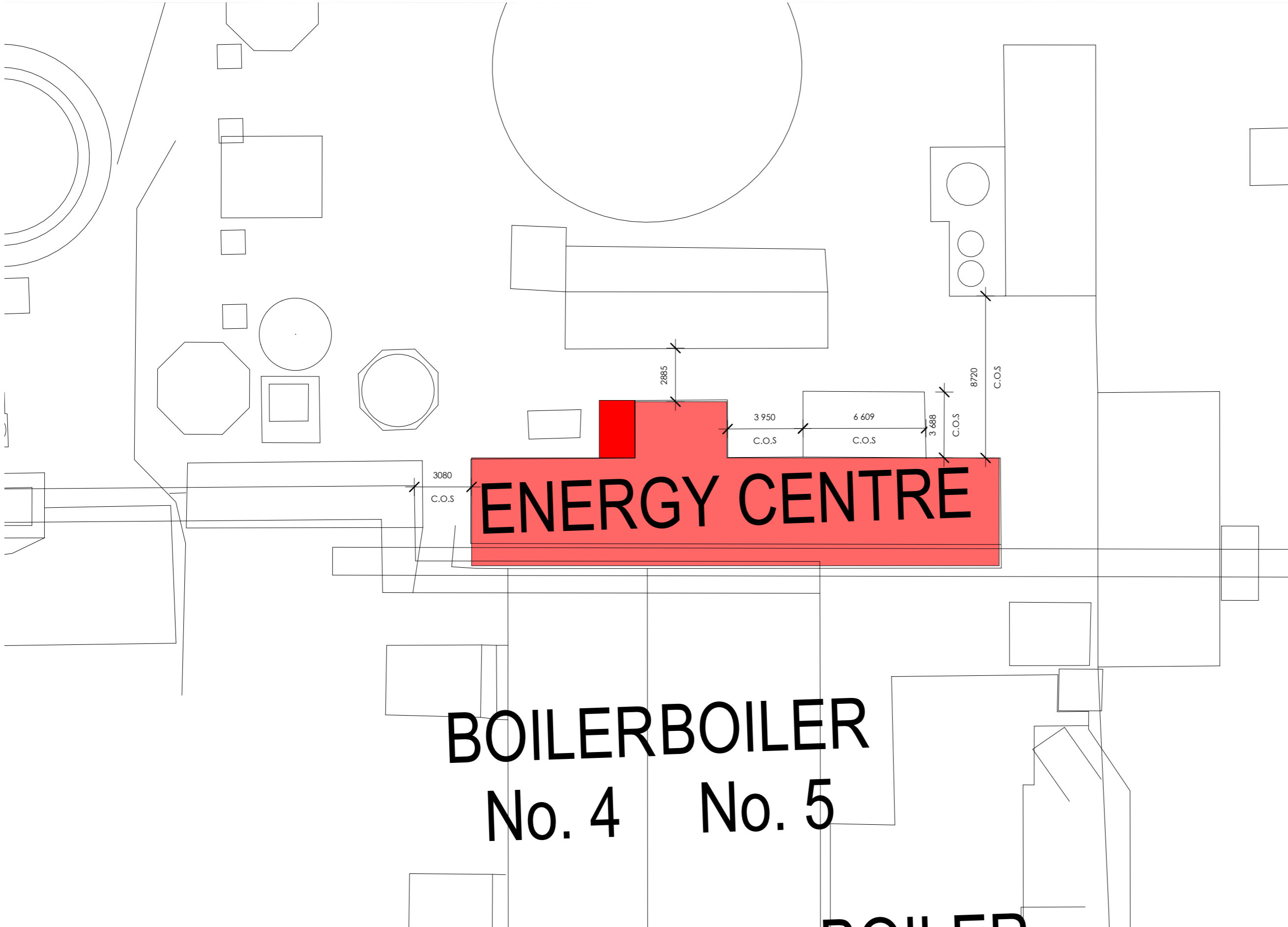

- General Notes:**
1. This drawing shall be read in conjunction with all other drawings & specifications.
 2. All work shall be strictly in accordance with the New Zealand Building Code, Local Territorial Authority Requirements, OSH Requirements & Regulations, and any other Statutory Requirements that may be applicable to this project.
 3. All work shall be of best trade practice.
 4. Do not scale from this drawing. Use only figured dimensions. The Contractor shall verify all dimensions on site, and report any discrepancies to the Architect before commencing work.

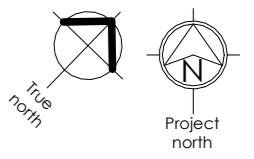

- Proposed Extension
- Existing Control Room

Site Plan Control Room - Boilers 4,5 &6

1 : 200



Copyright:
The copyright of this drawings remains the property of DLA Architects Limited and may only be used or re-used with DLA's prior written consent.

Project:
Clandeboye Bio Mass Control Room & Amenities

Client:
Fonterra Clandeboye





Drawing Title:
Site Plan Control Room - Boilers 4,5 &6
CAD File:

REV.	DATE	REVISION DETAILS
1	28/08/24	Tender Issue
0	27/05/24	First Issue

Scale: As indicated @ A3	Date: 29/08/24	Drawn: MX
Job No: C919	Designed: MA	Checked: CG
Drawing No: A1.03	Revision No: 1	

Demolition Notes:

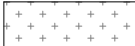
1. Protect existing services and parts of service systems that are to remain in place during the execution of the Contract Works. Provide temporary caps or covers to prevent the ingress of dust and other contaminants into the systems, ducts, pipes etc.
2. Make good all damage to existing footpaths, grounds and/or other services caused in carrying out the Contract Works.
3. Protect retained parts of existing building. Take care in cutting away and stripping out to reduce the amount of making good.
4. Support and brace the existing structure during the cutting of new openings or the replacement of structural parts. Prevent debris from overloading any part of the structure. Do not remove supports until the new work is strong enough to support the existing structure. Ensure all work remains structurally stable and sound.
5. **Make good all existing and new surfaces affected by the demolition and new work.**
6. Contractor to locate and plot **ALL** existing services.

-  demolish floor coverings
-  excavate earth work
-  existing gravel
-  existing asphalt
-  existing concrete
-  to be demolished

Boilers 1 & 2 Control Room Demolition Plan Notes

- remove all floor coverings to shaded works area
- existing ceiling grid Boiler Control Rooms 1 & 2 to be retained

General Notes:

1. This drawing shall be read in conjunction with all other drawings & specifications.
2. All work shall be strictly in accordance with the New Zealand Building Code, Local Territorial Authority Requirements, OSH Requirements & Regulations, and any other Statutory Requirements that may be applicable to this project.
3. All work shall be of best trade practice.
4. Do not scale from this drawing. Use only figured dimensions. The Contractor shall verify all dimensions on site, and report any discrepancies to the Architect before commencing work.

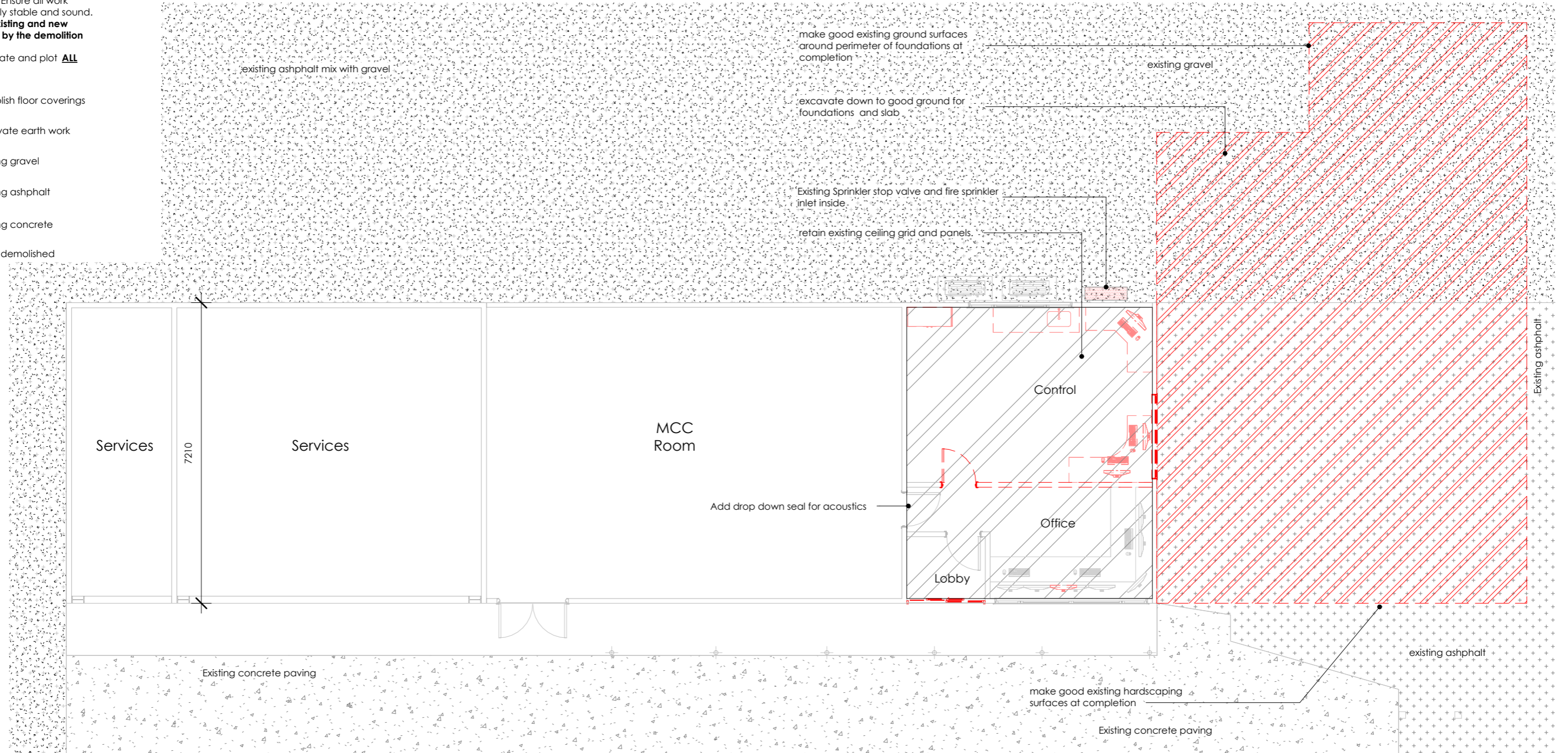

Existing and Demo Control Room Floor Plans - Boilers 1 & 2

1 : 100

dla. timaru.
 t: +64 3 683 1300
 e: admin@dla.co.nz
 49 george street,
 timaru, 7910

Copyright:
 The copyright of this drawings remains the property of DLA Architects Limited and may only be used or re-used with DLA's prior written consent.

Project:
 Clandeboye Bio Mass Control Room & Amenities

Client:
 Fonterra Clandeboye 

Drawing Title:
 Existing and Demo Control Room Floor Plans - Boilers 1 & 2
 CAD File:

REV.	DATE	REVISION DETAILS
1	28/08/24	Tender Issue
0	27/05/24	First Issue

Scale: As indicated @ A3	Date: 29/08/24	Drawn: MX
Job No: C919	Designed: MA	Checked: CG
Drawing No: A2.00	Revision No: 1	

General Notes:



1. This drawing shall be read in conjunction with all other drawings & specifications.
2. All work shall be strictly in accordance with the New Zealand Building Code, Local Territorial Authority Requirements, OSH Requirements & Regulations, and any other Statutory Requirements that may be applicable to this project.
3. All work shall be of best trade practice.
4. Do not scale from this drawing. Use only figured dimensions. The Contractor shall verify all dimensions on site, and report any discrepancies to the Architect before commencing work.

Boilers 4,5 & 6 Control Room Demolition Plan Notes

- retain existing plywood ceiling refer to proposed Reflected Ceiling Plan.
- remove all floor coverings to shaded works area.

Demolition Notes:

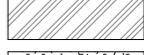
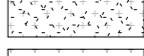
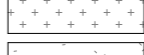
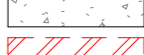
1. Protect existing services and parts of service systems that are to remain in place during the execution of the Contract Works. Provide temporary caps or covers to prevent the ingress of dust and other contaminants into the systems, ducts, pipes etc.
2. Make good all damage to existing footpaths, grounds and/or other services caused in carrying out the Contract Works.
3. Protect retained parts of existing building. Take care in cutting away and stripping out to reduce the amount of making good.
4. Support and brace the existing structure during the cutting of new openings or the replacement of structural parts. Prevent debris from overloading any part of the structure. Do not remove supports until the new work is strong enough to support the existing structure. Ensure all work remains structurally stable and sound.
5. **Make good all existing and new surfaces affected by the demolition and new work.**
6. Contractor to locate and plot **ALL** existing services.

-  demolish floor coverings
-  excavate earth work
-  existing gravel
-  existing asphalt
-  existing concrete
-  to be demolished

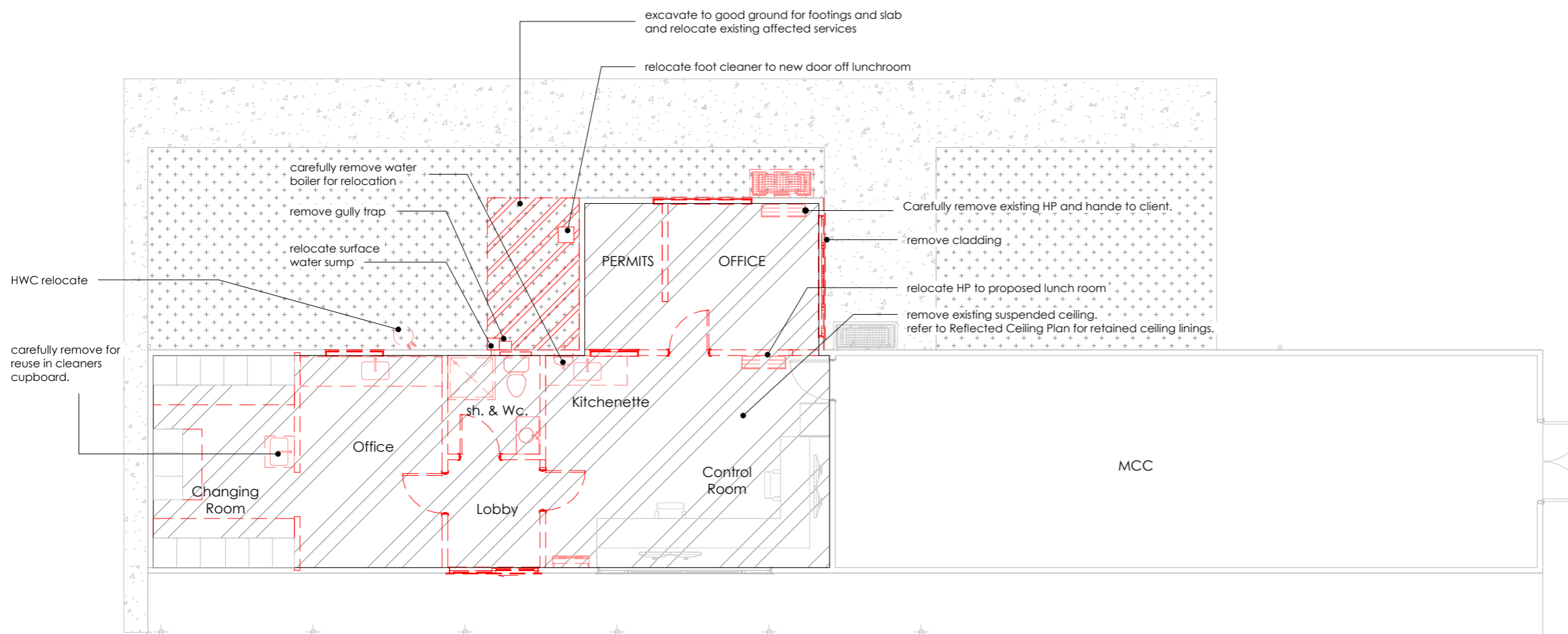

Existing and Demo Control Room Floor Plans - Boilers 4,5 & 6.

1 : 100

Sanitaryware Schedule - Boiler 1,2 Control Room and Amenities

Accessible Toilet:

- Caroma Cosmo Care pan, Concealed trap, Caroma Caravelle Care seat and Caroma Cosmo 2 Connector Cistern.
- Caroma Care 500 wall basin with Vitreous China Care Shroud, 1TH, pop-up waste and overflow
- Marketti Healthcare Swivel basin mixer
- Raymor Care Classic L Rail 750mm
- Raymor Care Classic 600mm Grab Rail (Door)
- Mirrox 400 x 800 frameless, polished edge, adhesive fixed mirror.
- Coat Hook, Miles Nelson 102 CP
- Install toilet roll holder, soap dispenser, paper towel dispenser, waste bins (supplied by Fonterra)

Unisex WC:

- Caroma Aire Concorde Connector Toilet Suite
- Caroma Concorde wall basin 1TH with pop-up waste & shroud
- Marketti Blade basin mixer
- Mirrox 400 x 800 frameless, polished edge, adhesive fixed mirror.
- Coat Hook, Miles Nelson 102 CP
- Install toilet roll holder, soap dispenser, paper towel dispenser, waste bins (supplied by Fonterra)

Permits Kitchenette

- Oliveri Single Bowl Universal Sink
- Raymor Alpha Gooseneck Kitchen Mixer
- Zip Manual Boiling Wate Unit 7.0L
- Install soap dispenser, paper towel dispenser (supplied by Fonterra)

Laboratory

- Acero Custom Stainless Steel Bench
- Comlab Bench Mounted Laboratory mixing Set with Swivel Gooseneck Outlet LCN113N
- Install soap dispenser, paper towel dispenser (supplied by Fonterra)

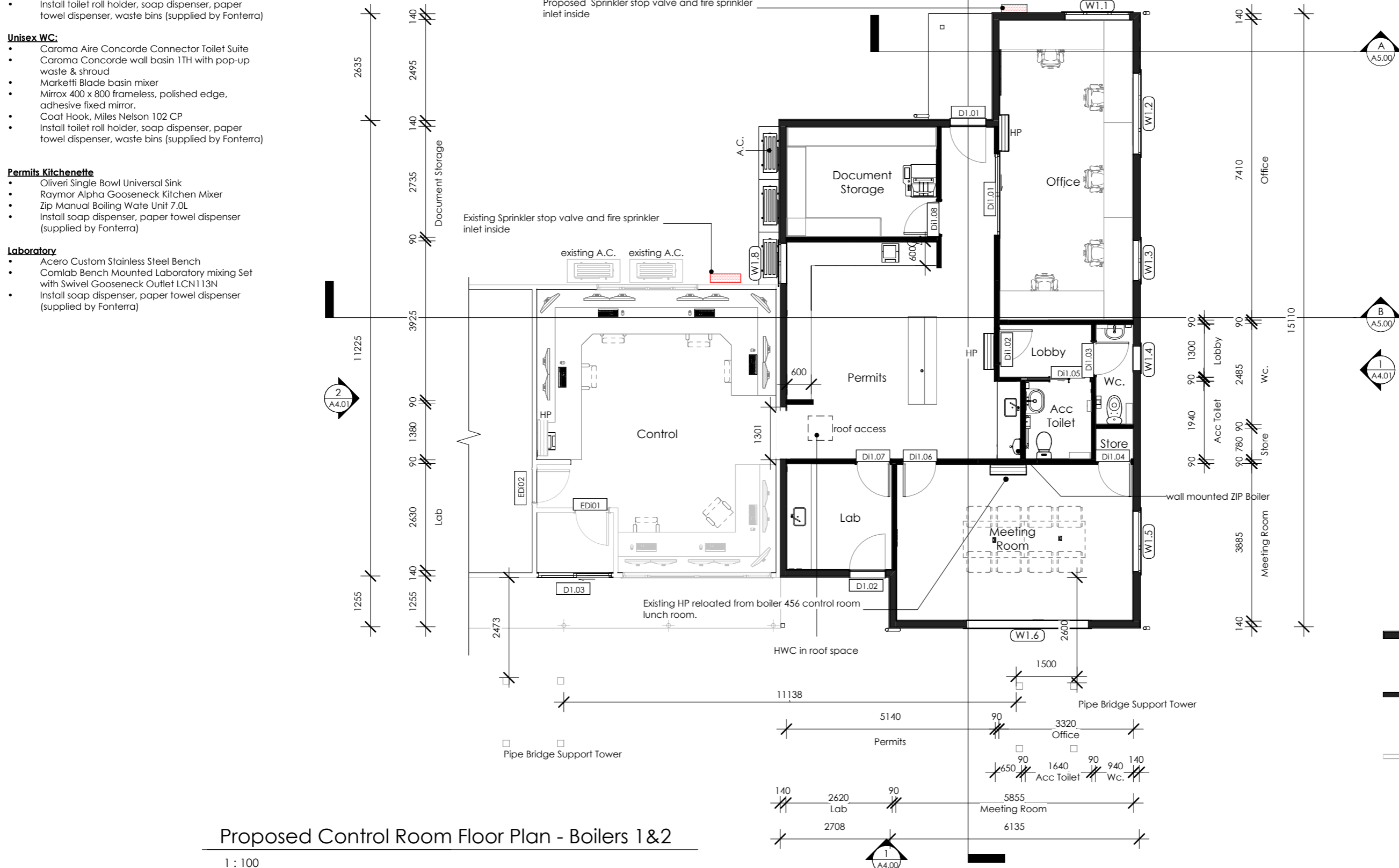

General Notes:

1. This drawing shall be read in conjunction with all other drawings & specifications.
2. All work shall be strictly in accordance with the New Zealand Building Code, Local Territorial Authority Requirements, OSH Requirements & Regulations, and any other Statutory Requirements that may be applicable to this project.
3. All work shall be of best trade practice.
4. Do not scale from this drawing. Use only figured dimensions. The Contractor shall verify all dimensions on site, and report any discrepancies to the Architect before commencing work.

Dimensions are to framing, contractor to allow for lining thickness.

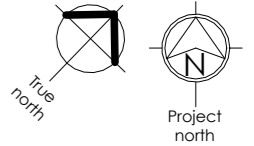

- Proposed 140x45 Framing Exterior Wall
140x45 H1.2 SG8 studs
@ 600crs dwangs
@ 800crs
- Proposed 90x45 Timber Framing Interior Walls
90x45 H1.2 SG8 studs
@ 600crs, dwangs
@ 800crs
- Existing Walls

Proposed Control Room Floor Plan - Boilers 1&2

1 : 100



Copyright:
The copyright of this drawings remains the property of DLA Architects Limited and may only be used or re-used with DLA's prior written consent.

Project:
Clandeboy Bio Mass Control Room & Amenities

Client:
Fonterra Clandeboy

Drawing Title:
Proposed Control Room Floor Plan - Boilers 1&2

CAD File:

REV.	DATE	REVISION DETAILS
1	28/08/24	Tender Issue
0	27/05/24	First Issue

Scale: As indicated @ A3	Date: 29/08/24	Drawn: MX
Job No: C919	Designed: MA	Checked: CG
Drawing No: A2.02	Revision No: 1	

Sanitaryware Schedule - Boiler 4,5,6 Control Room and Amenities

Male Shower & WC // Female Shower & WC

- Caroma Aire Concorde Connector Toilet Suite
- Caroma Concorde wall basin 1TH
- Markefi Blade basin mixer
- Mirrox 400 x 800 frameless, polished edge, adhesive fixed mirror
- Coat Hook, Miles Nelson 102 CP
- Install toilet roll holder, soap dispenser, paper towel dispenser, waste bins (supplied by Fonterra)
- Raymor Cove 3 Sided 900x900 Alcove Semi Frameless Shower
- Raymor Alpha Shower Mixer
- Raymor Multi-Spray Slide Shower

Cleaners

- Install existing relocated cleaners sink and tapware
- Install shelving above sink

Lunch Room

- Oliveri Single Bowl Universal Sink
- Raymor Alpha Gooseneck Kitchen Mixer
- Install existing relocated wall mounted Rheem water boiler
- Install soap dispenser, paper towel dispenser (supplied by Fonterra)

General Notes:

1. This drawing shall be read in conjunction with all other drawings & specifications.
2. All work shall be strictly in accordance with the New Zealand Building Code, Local Territorial Authority Requirements, OSH Requirements & Regulations, and any other Statutory Requirements that may be applicable to this project.
3. All work shall be of best trade practice.
4. Do not scale from this drawing. Use only figured dimensions. The Contractor shall verify all dimensions on site, and report any discrepancies to the Architect before commencing work.

Dimensions are to framing, contractor to allow for lining thickness.

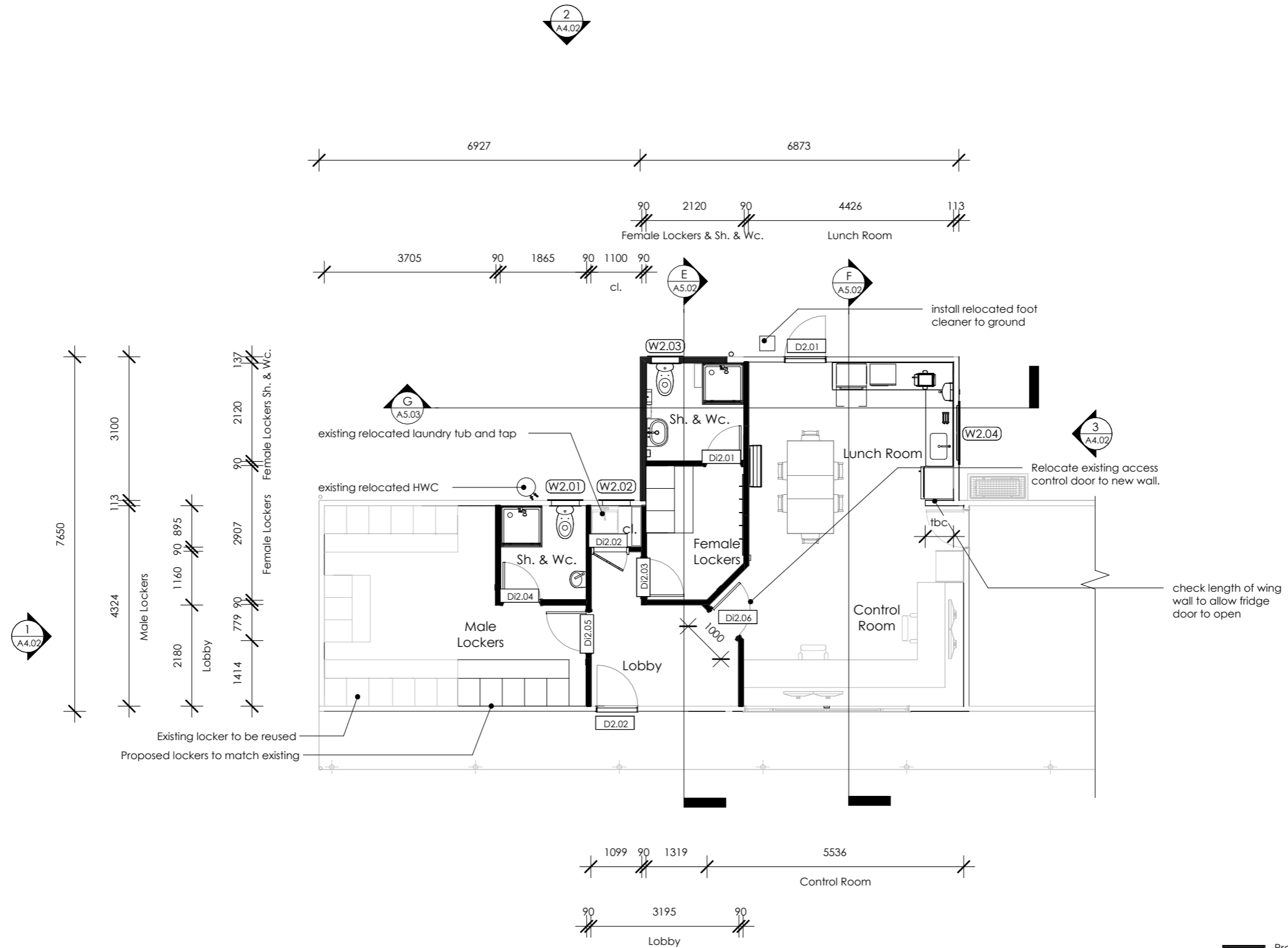
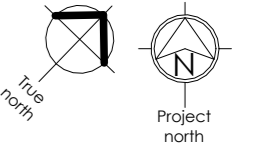

Proposed Control Room Floor Plan - Boilers 4,5&6

1 : 100

Proposed 140x45 Framing Exterior Wall
140x45 H1.2 SG8 studs
@ 600crs dwangs
@ 800crs

Proposed 90x45 Timber Framing Interior Walls
90x45 H1.2 SG8 studs
@ 600crs, dwangs
@ 800crs

Existing Walls



Copyright:
The copyright of this drawings remains the property of DLA Architects Limited and may only be used or re-used with DLA's prior written consent.

Project:
Clandeboy Bio Mass Control Room & Amenities

Client:
Fonterra Clandeboy

Drawing Title:
Proposed Control Room Floor Plan - Boilers 4,5&6
CAD File:

REV.	DATE	REVISION DETAILS
1	28/08/24	Tender Issue
0	27/05/24	First Issue

Scale: As indicated @ A3	Date: 29/08/24	Drawn: MX
Job No: C919	Designed: MA	Checked: CG
Drawing No: A2.03	Revision No: 1	

DOWNPIPE CALCULATIONS

Box Gutter 125 Roof area served by 80mm Downpipe from Dimond Technical Manual - Table 3.1G

Rainfall Intensity, I(mm/hr)	Roof Area Served per DP
40	168m ²
50	134m ²
60	111m ²
70	96m ²
80	84m ²
90	75m ²
100	67m ²
120	56m ²
140	48m ²
160	42m ²
180	37m ²
200	33m ²

Max roof area to be served by 80mm downpipe:
Roof G: 133m² / 2 DP = 66.5m²

Drainage Plan Note:

Existing subseil services in works area.
*Co-ordinate existing and proposed services with Aurecon Ltd.

Location To Be Confirm By Aurecon
Drain Location And Direction To Be Confirm By Aurecon

Sanitaryware Schedule - Boiler 1,2 Control Room and Amenities

Accessible Toilet:

- Caroma Cosmo Care pan, Concealed trap, Caroma Caravelle Care seat and Caroma Cosmo 2 Connector Cistern.
- Caroma Care 500 wall basin with Vitreous China Care Shroud, 1TH, pop-up waste and overflow
- Marketti Healthcare Swivel basin mixer
- Raymor Care Classic L Rail 750mm
- Raymor Care Classic 600mm Grab Rail (Door)
- Mirrox 400 x 800 frameless, polished edge, adhesive fixed mirror.
- Coat Hook, Miles Nelson 102 CP
- Install toilet roll holder, soap dispenser, paper towel dispenser, waste bins (supplied by Fonterra)

Unisex WC:

- Caroma Aire Concorde Connector Toilet Suite
- Caroma Concorde wall basin 1TH with pop-up waste & shroud
- Marketti Blade basin mixer
- Mirrox 400 x 800 frameless, polished edge, adhesive fixed mirror.
- Coat Hook, Miles Nelson 102 CP
- Install toilet roll holder, soap dispenser, paper towel dispenser, waste bins (supplied by Fonterra)

Permits Kitchenette

- Oliveri Single Bowl Universal Sink
- Raymor Alpha Gooseneck Kitchen Mixer
- Zip Manual Boiling Wate Unit 7.0L
- Install soap dispenser, paper towel dispenser (supplied by Fonterra)

Laboratory

- Acero Custom Stainless Steel Bench
- Comlab Bench Mounted Laboratory mixing Set with Swivel Gooseneck Outlet LCN113N
- Install soap dispenser, paper towel dispenser (supplied by Fonterra)

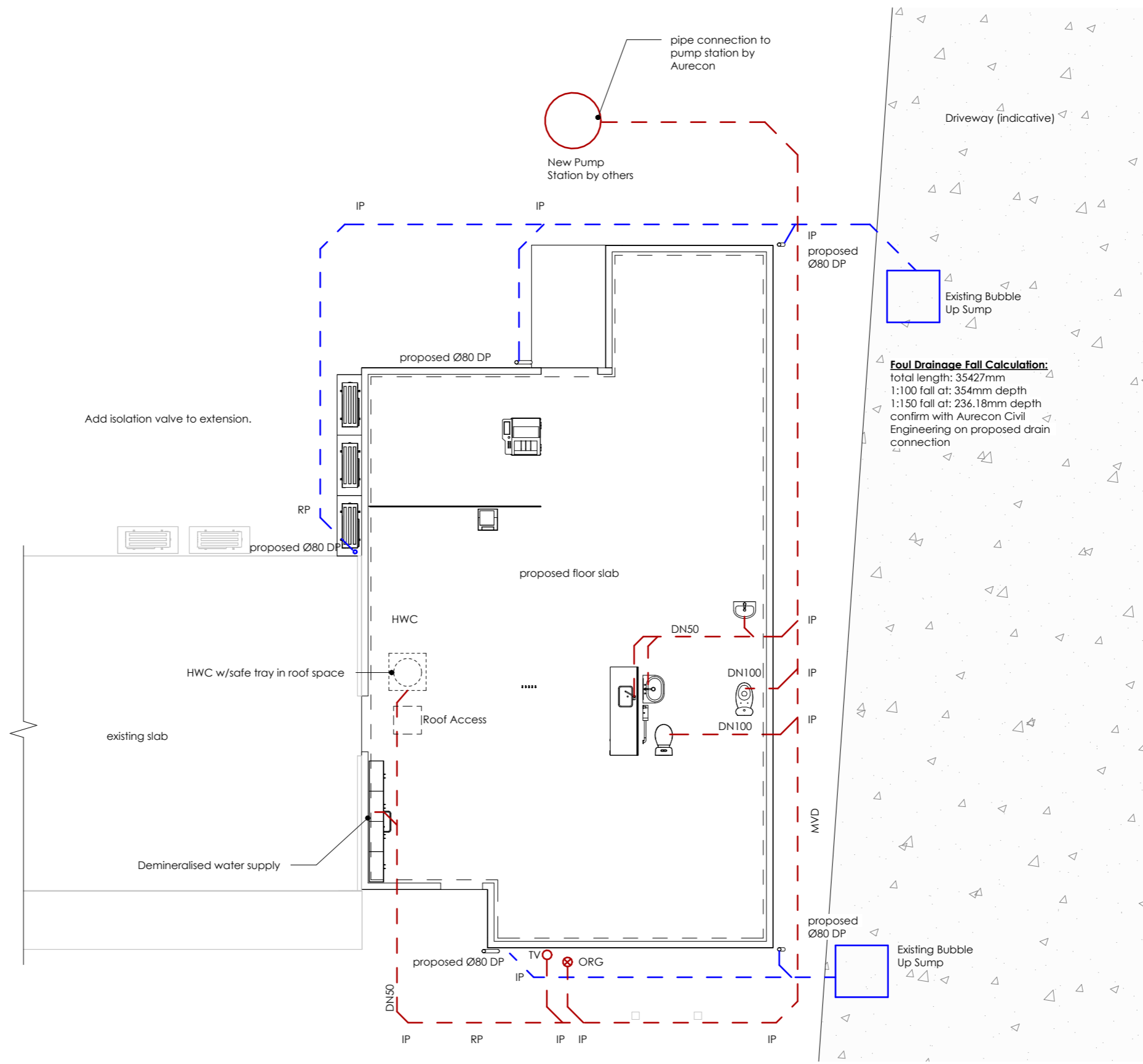

General Notes:

1. This drawing shall be read in conjunction with all other drawings & specifications.
2. All work shall be strictly in accordance with the New Zealand Building Code, Local Territorial Authority Requirements, OSH Requirements & Regulations, and any other Statutory Requirements that may be applicable to this project.
3. All work shall be of best trade practice.
4. Do not scale from this drawing. Use only figured dimensions. The Contractor shall verify all dimensions on site, and report any discrepancies to the Architect before commencing work.

Plumbing & Drainage Notes:

- All sanitary and drainage works and materials shall be installed in accordance with AS/NZS 3500 Part 2.
- Plumbing must be inspected as required by local authorities before being covered.
- Conceal all pipework where possible and vent all drains as necessary.
- All dimensions, sizes, invert levels and locations of services to be verified on site before work commences.
- Drainage gradients: Install drains to gradients noted & to suit the levels of the structure and the sewer main connection.
- Provide inspection openings (cleaning eyes) as noted and as required by and in accordance with AS/NZS 3500.
- All drains up to slab level shall be no less than DN65, except where DN50 discharge pipes are permitted to connect into FWG.
- All fixture discharge pipes above slab level from showers, basins, sinks, urinals shall be DN50 unless noted otherwise.
- Amenities floor slab level is RL0.000.

Drain Gradients:

DN50	1:40 Gradient
DN65	1:40 Gradient
DN80	1:60 Gradient
DN100	1:60 Gradient
DN150	1:100 Gradient

Plumbing Key:

MVD	Main vented Drain
VBD	Vented Branch Drain
ORG	Overflow Relief Gully
HWC	Hot Water Cylinder
TV	Terminal Vent
d/w	Dishwasher
DP	Down Pipe
RP	Rodding Point
IP	Inspection Point

Note: Unless noted otherwise all dimensions are to Grid lines.

Legend:

	Existing Sewer
	Sewer Proposed
	Stormwater Existing
	Stormwater Proposed

DRAWING NOTE:

Drawing to be printed in Colour

Plumbing and Drainage Plan Control Room - Boilers 1 & 2

1 : 100

dla. timaru.
t: +64 3 683 1300
e: admin@dla.co.nz
49 george street,
timaru, 7910

Copyright:
The copyright of this drawings remains the property of DLA Architects Limited and may only be used or re-used with DLA's prior written consent.

Project:
Clandeboyne Bio Mass Control Room & Amenities

Client:
Fonterra Clandeboyne

Drawing Title:
Plumbing and Drainage Plan Control Room - Boilers 1 & 2
CAD File:

REV.	DATE	REVISION DETAILS
1	28/08/24	Tender Issue
0	27/05/24	First Issue

Scale: As indicated @ A3	Date: 29/08/24	Drawn: MX
Job No: C919	Designed: MA	Checked: CG
Drawing No: A2.10	Revision No: 1	

DOWNPIPE CALCULATIONS

Box Gutter 125 Roof area served by 80mm Downpipe from Dimond Technical Manual - Table 3.1G

Rainfall Intensity, I(mm/hr)	Roof Area Served per DP
40	168m ²
50	134m ²
60	111m ²
70	96m ²
80	84m ²
90	75m ²
100	67m ²
120	56m ²
140	48m ²
160	42m ²
180	37m ²
200	33m ²

**Max roof area to be served by 80mm downpipe:
Roof G: 133m² / 2 DP = 66.5m²**

Drainage Plan Note:

Existing subseil services in works area.
*Co-ordinate existing and proposed services with Aurecon Ltd.

Location To Be Confirm By Aurecon
Drain Location And Direction To Be Confirm By Aurecon

Sanitaryware Schedule - Boiler 4,5,6 Control Room and Amenities

Male Shower & WC // Female Shower & WC

- Caroma Aire Concorde Connector Toilet Suite
- Caroma Concorde wall basin 1TH
- Marketti Blade basin mixer
- Mirrox 400 x 800 frameless, polished edge, adhesive fixed mirror
- Coat Hook, Miles Nelson 102 CP
- Install toilet roll holder, soap dispenser, paper towel dispenser, waste bins (supplied by Fonterra)
- Raymor Cove 3 Sided 900x900 Alcove Semi Frameless Shower
- Raymor Alpha Shower Mixer
- Raymor Multi-Spray Slide Shower

Cleaners

- Install existing relocated cleaners sink and tapware
- Install shelving above sink

Lunch Room

- Oliveri Single Bowl Universal Sink
- Raymor Alpha Gooseneck Kitchen Mixer
- Install existing relocated wall mounted Rheem water boiler
- Install soap dispenser, paper towel dispenser (supplied by Fonterra)

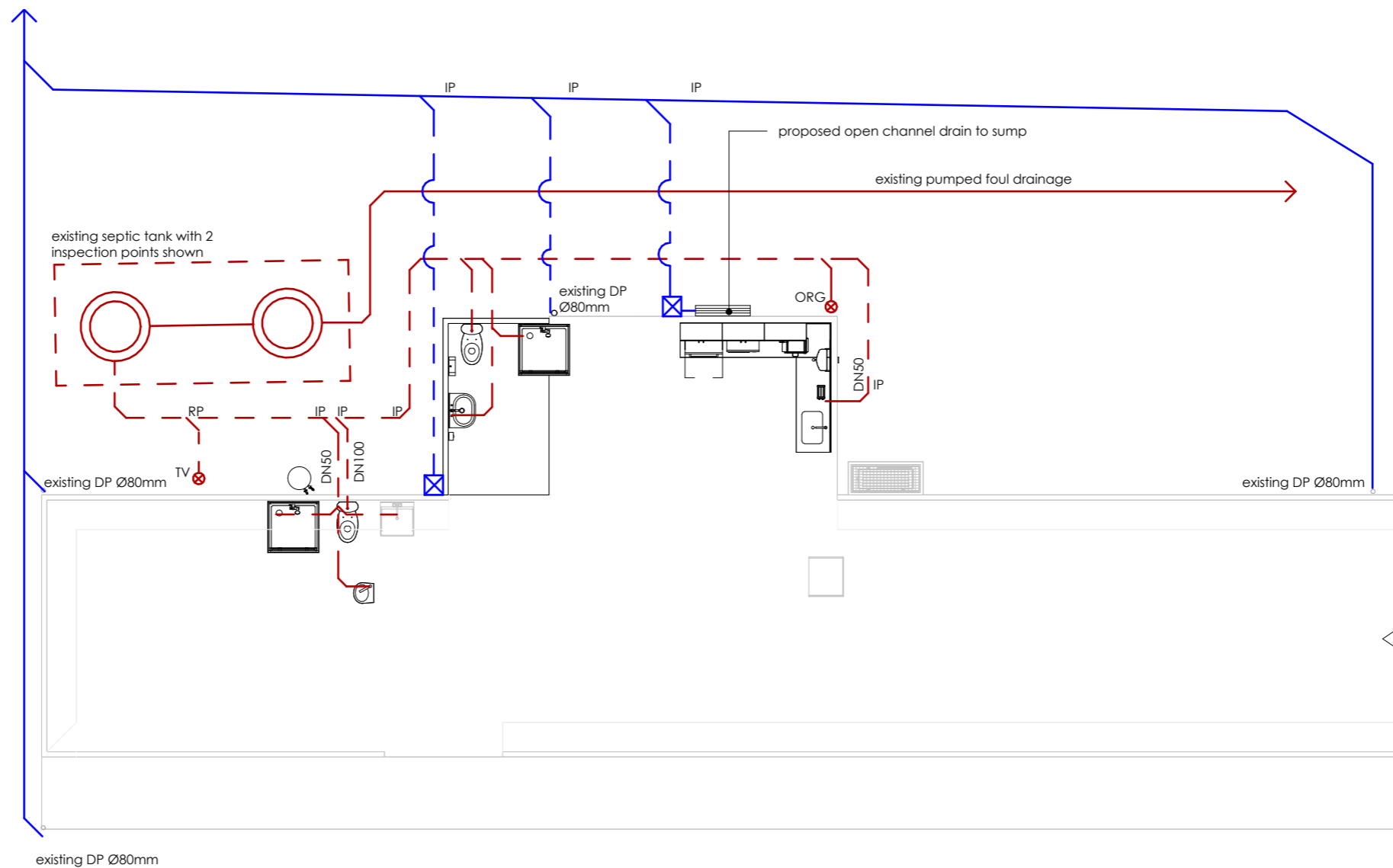

General Notes:

1. This drawing shall be read in conjunction with all other drawings & specifications.
2. All work shall be strictly in accordance with the New Zealand Building Code, Local Territorial Authority Requirements, OSH Requirements & Regulations, and any other Statutory Requirements that may be applicable to this project.
3. All work shall be of best trade practice.
4. Do not scale from this drawing. Use only figured dimensions. The Contractor shall verify all dimensions on site, and report any discrepancies to the Architect before commencing work.

Plumbing & Drainage Notes:

- All sanitary and drainage works and materials shall be installed in accordance with AS/NZS 3500 Part 2.
- Plumbing must be inspected as required by local authorities before being covered.
- Conceal all pipework where possible and vent all drains as necessary.
- All dimensions, sizes, invert levels and locations of services to be verified on site before work commences.
- Drainage gradients: Install drains to gradients noted & to suit the levels of the structure and the sewer main connection.
- Provide inspection openings (cleaning eyes) as noted and as required by and in accordance with AS/NZS 3500.
- All drains up to slab level shall be no less than DN65, except where DN50 discharge pipes are permitted to connect into FWG.
- All fixture discharge pipes above slab level from showers, basins, sinks, urinals shall be DN50 unless noted otherwise.
- Amenities floor slab level is RL0.000.

Drain Gradients:

DN50	1:40 Gradient
DN65	1:40 Gradient
DN80	1:60 Gradient
DN100	1:60 Gradient
DN150	1:100 Gradient

Plumbing Key:

MVD	Main vented Drain
VBD	Vented Branch Drain
ORG	Overflow Relief Gully
HWC	Hot Water Cylinder
TV	Terminal Vent
d/w	Dishwasher
DP	Down Pipe
RP	Rodding Point
IP	Inspection Point

Note: Unless noted otherwise all dimensions are to Grid lines.

Legend:

—	Existing Sewer
- - -	Sewer Proposed
—	Stormwater Existing
- - -	Stormwater Proposed

DRAWING NOTE:

Drawing to be printed in Colour

Plumbing and Drainage Plan Control Room - Boilers 4,5 & 6

1 : 100



Copyright:
The copyright of this drawings remains the property of DLA Architects Limited and may only be used or re-used with DLA's prior written consent.

Project:
Clandeboyne Bio Mass Control Room & Amenities

Client:
Fonterra Clandeboyne

Drawing Title:
Plumbing and Drainage Plan Control Room - Boilers 4,5 & 6
CAD File:

REV.	DATE	REVISION DETAILS
1	28/08/24	Tender Issue
0	27/05/24	First Issue

Scale: As indicated @ A3	Date: 29/08/24	Drawn: MX
Job No: C919	Designed: MA	Checked: CG
Drawing No: A2.11	Revision No: 1	

General Notes:





1. This drawing shall be read in conjunction with all other drawings & specifications.
2. All work shall be strictly in accordance with the New Zealand Building Code, Local Territorial Authority Requirements, OSH Requirements & Regulations, and any other Statutory Requirements that may be applicable to this project.
3. All work shall be of best trade practice.
4. Do not scale from this drawing. Use only figured dimensions. The Contractor shall verify all dimensions on site, and report any discrepancies to the Architect before commencing work.

Fire Safety Note

Fire safety features to be amended to suit (MCP, Sounder, Extinguishers, Exit sign, Smoke Detector, Sprinkler and any other component) to make up the whole system. Design by a qualified fire safety consultant.

PLANS MUST BE READ IN CONJUNCTION WITH FIRE REPORT BY HOLMES FIRE

Electrical Legend:

-  Double switched socket outlet flush mounted horizontal.
-  Double data point mounted horizontal.
-  Existing double switched socket outlet flush mounted horizontal.
-  Existing double data point mounted horizontal.

Notes:

Refer to joinery drawings for exact locations of outlets, switches. Confirm outlet locations onsite
 Electrical Plans must be read in conjunction with Electrical Specification from **Micon Engineering Ltd.**

1. Relocated UPS PPTS shift to new location, circuit SC16, PPTS are with round earth pin
2. Relocated UPS PPTS in new location, circuit CS1, PPTS are with round earth pin
3. Existing DB02, lighting UPS lights(EMG), power and UPS DB, include circuits CS1 and SC16

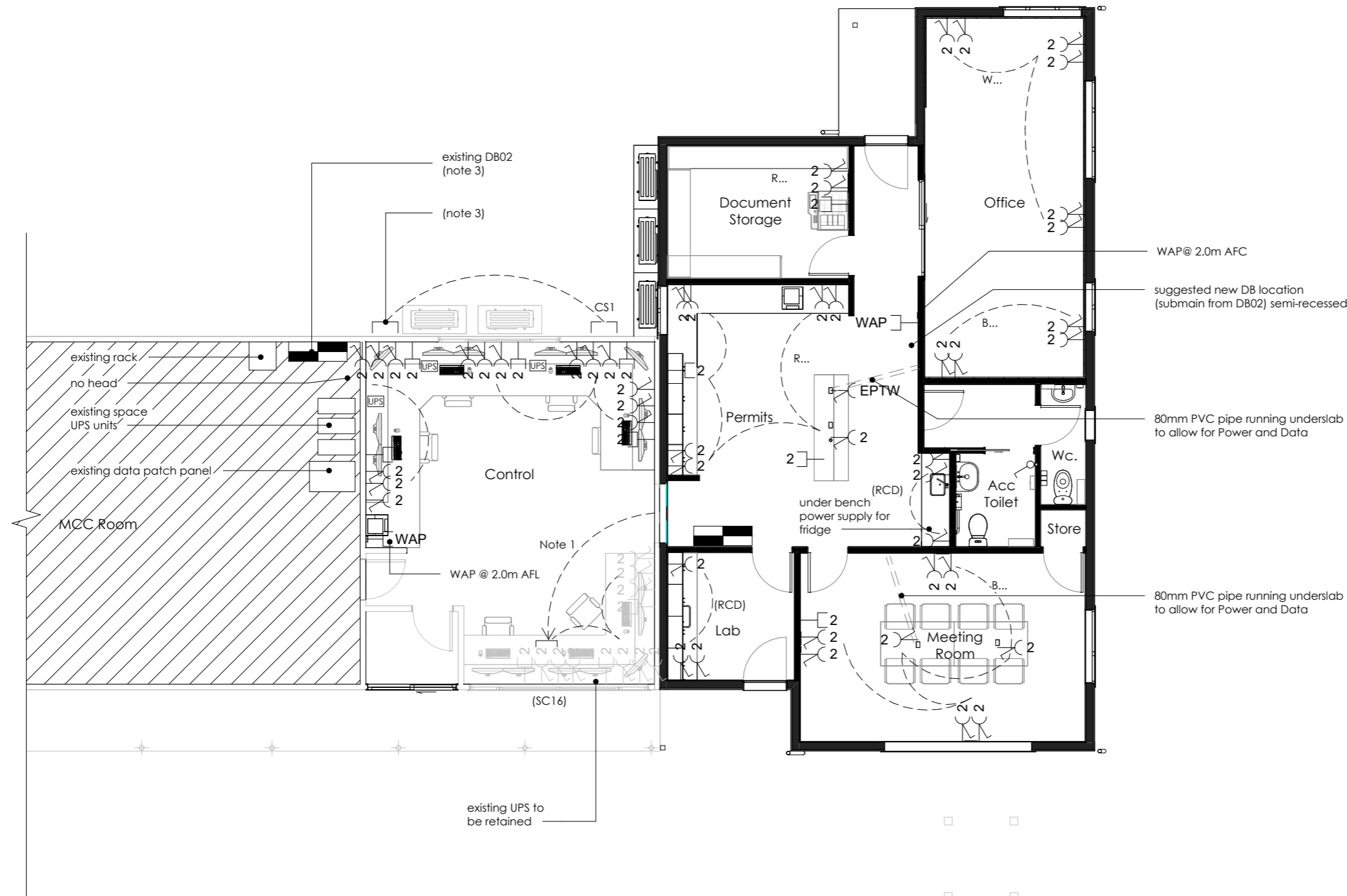

Electrical Plan Control Room - Boilers1 &2

1 : 100



Copyright:
 The copyright of this drawings remains the property of DLA Architects Limited and may only be used or re-used with DLA's prior written consent.

Project:
Clandeboy Bio Mass Control Room & Amenities

Client:
Fonterra Clandeboy

Drawing Title:
Electrical and Fire Safety Plan Control Room - Boilers1 &2
 CAD File:

REV.	DATE	REVISION DETAILS
1	28/08/24	Tender Issue
0	27/05/24	First Issue

Scale: As indicated @ A3	Date: 29/08/24	Drawn: MX
Job No: C919	Designed: MA	Checked: CG
Drawing No: A2.20	Revision No: 1	

General Notes:





1. This drawing shall be read in conjunction with all other drawings & specifications.
2. All work shall be strictly in accordance with the New Zealand Building Code, Local Territorial Authority Requirements, OSH Requirements & Regulations, and any other Statutory Requirements that may be applicable to this project.
3. All work shall be of best trade practice.
4. Do not scale from this drawing. Use only figured dimensions. The Contractor shall verify all dimensions on site, and report any discrepancies to the Architect before commencing work.

Fire Safety Note

Fire safety features to be amended to suit (MCP, Sounder, Extinguishers, Exit sign, Smoke Detector, Sprinkler and any other component) to make up the whole system. Design by a qualified fire safety consultant.

PLANS MUST BE READ IN CONJUNCTION WITH FIRE REPORT BY HOLMES FIRE

Electrical Legend:

-  Double switched socket outlet flush mounted horizontal.
-  Double data point mounted horizontal.
-  Existing double switched socket outlet flush mounted horizontal.
-  Existing double data point mounted horizontal.

Notes:

Refer to joinery drawings for exact locations of outlets, switches. Confirm outlet locations onsite

Electrical Plans must be read in conjunction with Electrical Specification from **Micon Engineering Ltd.**

1. Retain existing UPS PPTS (UPS switchboard #6 and #7 PPTS indicated on layout drawing are additional)

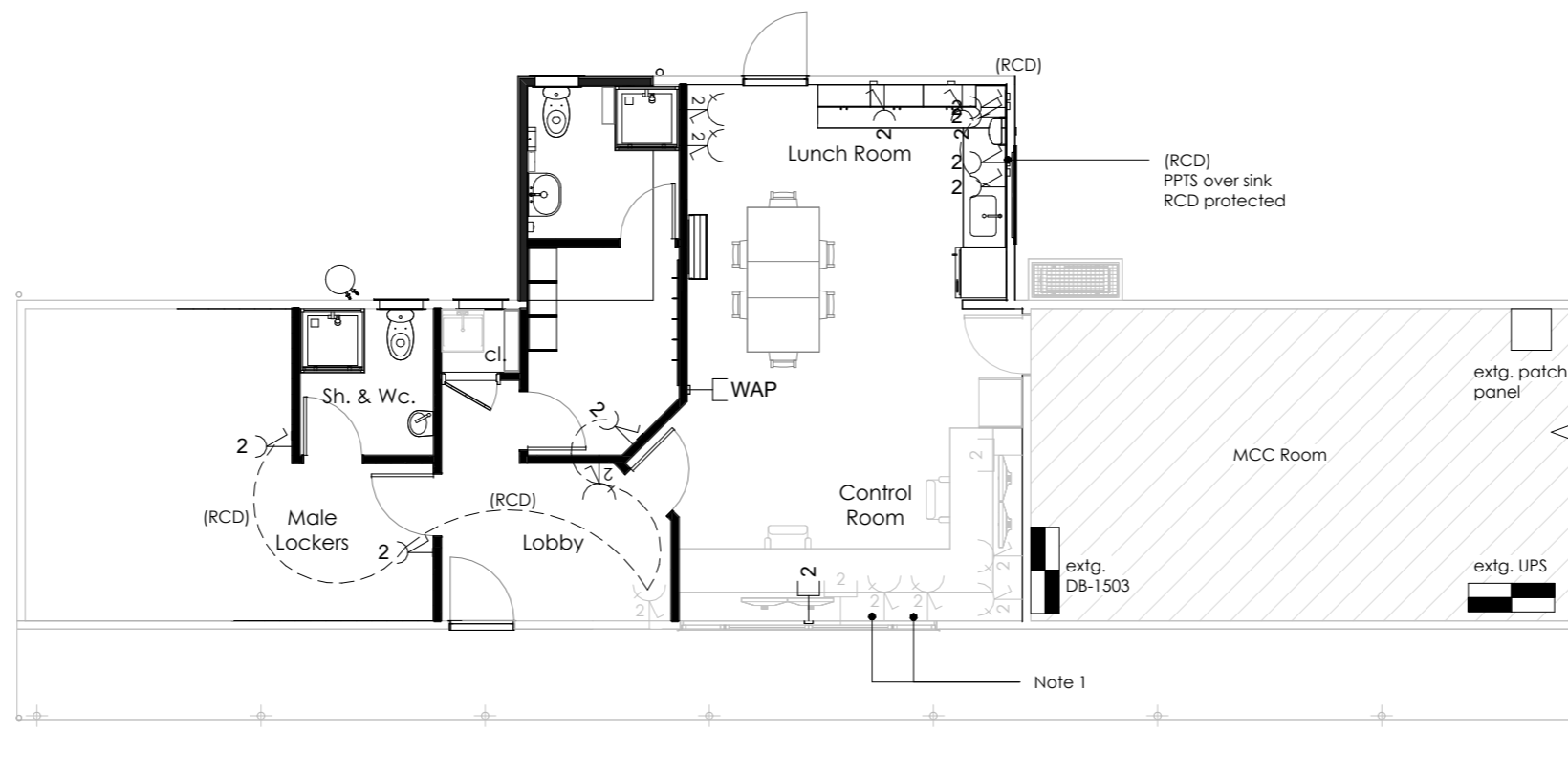

Electrical Plan Control Room - Boilers 4,5&6

1 : 100



Copyright:
The copyright of this drawings remains the property of DLA Architects Limited and may only be used or re-used with DLA's prior written consent.

Project:
Clandeboyne Bio Mass Control Room & Amenities

Client:
Fonterra Clandeboyne

Drawing Title:
Electrical and Fire Safety Plan Control Room - Boilers 4,5&6
CAD File:

REV.	DATE	REVISION DETAILS
1	28/08/24	Tender Issue
0	27/05/24	First Issue

Scale: As indicated @ A3	Date: 29/08/24	Drawn: MX
Job No: C919	Designed: MA	Checked: CG
Drawing No: A2.21	Revision No: 1	

- General Notes:**
1. This drawing shall be read in conjunction with all other drawings & specifications.
 2. All work shall be strictly in accordance with the New Zealand Building Code, Local Territorial Authority Requirements, OSH Requirements & Regulations, and any other Statutory Requirements that may be applicable to this project.
 3. All work shall be of best trade practice.
 4. Do not scale from this drawing. Use only figured dimensions. The Contractor shall verify all dimensions on site, and report any discrepancies to the Architect before commencing work.







- Ceiling Finishes Notes:**
1. All Plaster board wall and ceiling junctions to be square stopped.
 2. Read in conjunction with mechanical and electrical drawings for all air conditioning requirements, duct, grills & lighting plans.
 3. Reflected Ceiling Plans to be read in conjunction with fire design philosophy for signs etc.
 4. Reflected Ceiling Plans to be read in conjunction with Colour Schedule.
 5. Co-ordinate & be aware of smoke detector positions / layouts.
 6. Sprinkler system to be extended.
 7. Refer to Resene TechSpec in specifications for paint systems

HVAC, Fresh Air/Ventilation & Sprinkler System Note



HVAC, Fresh air, ventilation and sprinkler system to be designed by contractor and comply with all Fonterra performance requirements, building code clauses and respective design standards.

Fonterra requirements are detailed in specification appendix and must be read in conjunction with all other documentation.

Ceiling legend:

-  MODENA MINI LED W PREMIUM 4000K
-  Heights indicated are taken from RL0.000
-  2 Way Switch
-  MONZA LED OPAL (PX2250136)
-  MONZA II LED (PX2250150)
-  Existing troffes light in ceiling grid
-  exterior flood light

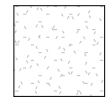
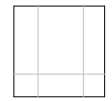
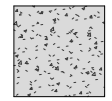

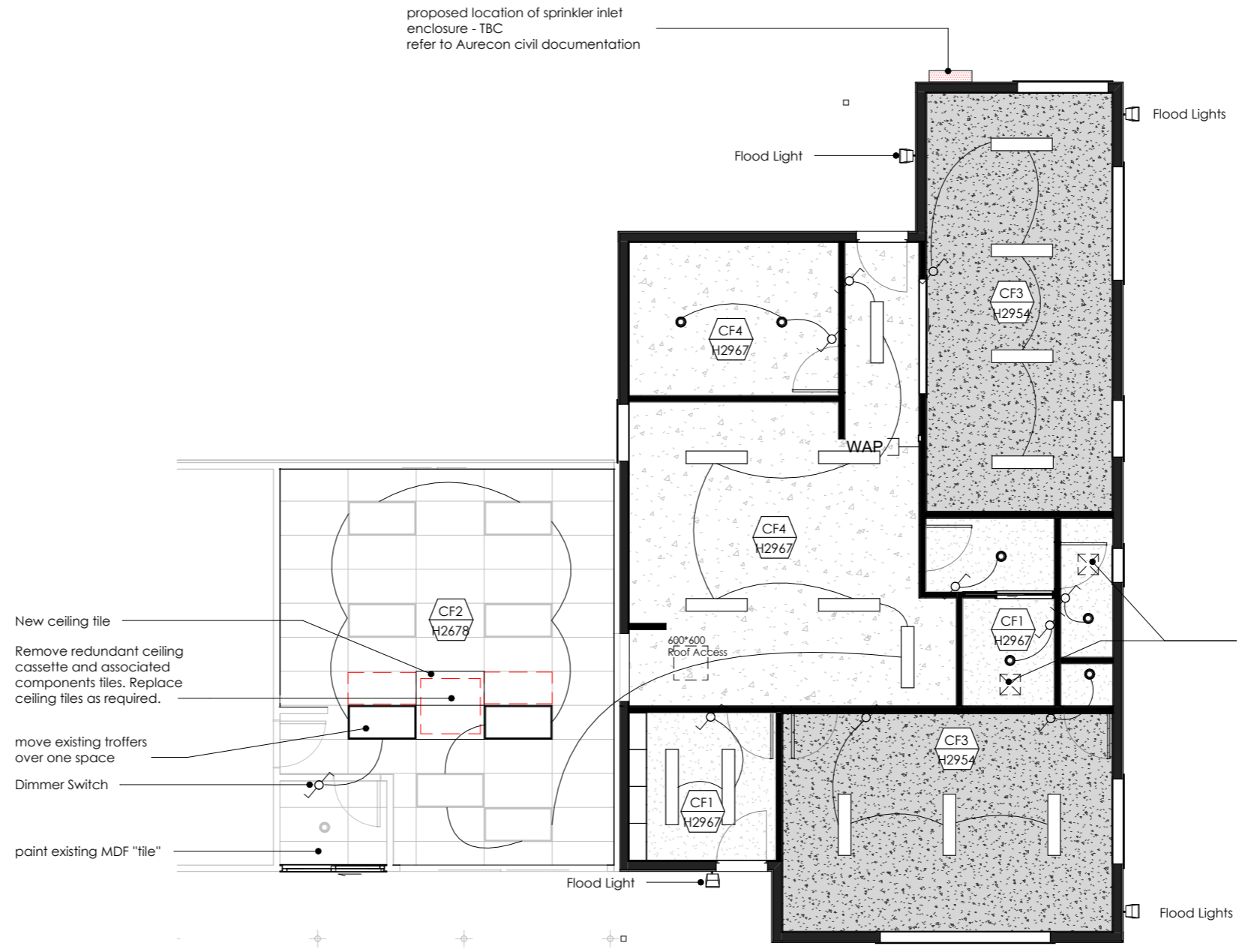

Ceiling Finishes Key:

-  **Gib Aqualine**
13mm Gib Aqualine with Rondo Gib Quiet Clip, with painted finish
-  **Existing Ceiling Tiles**
1200 x 600mm existing ceiling tile grid.
-  **GBDFA 30A Double Gib Ceiling**
GBDFA 30A Double Gib Std. (partial system - supplementary). Ceiling noise control system. with Rondo Gib Quiet Clip. with painted finish.
-  **Standard Gib**
13mm Standard Gib with Rondo Gib Quiet Clip, with painted finish.



Reflected Ceiling / Lighting Plan Control Room - Boilers 1&2

1 : 100

Luminaire Schedule														
Project: Control Room - Boilers 1&2														
Symbol	Type	Qty	Manufacturer	Code	Description	Luminous Flux (lm)	Power (W)	Driver	Dimensions	Optic	CRI	CCT	IP	LLF
	A1	13	PXF Lighting	EB003.1111.840.A000	MONZA LED OPAL (PX2250136)	4146	35	Standard	1080x223x50mm	Opal	Ra 84	4000K	IP20	0.800
	A2	2	PXF Lighting	EB005.1111.840.A000	MONZA II LED (PX2250150)	5187	42	Standard	1330x223x50mm	Opal	Ra 84	4000K	IP20	0.800
	B	5	PXF Lighting	EA003.1111.840.A000	MODENA MINI LED W PREMIUM 4000K	2133	18	Standard	2315x90mm	Opal	Ra 84	4000K	IP54	0.800
	W	4	LIGMAN	LEE-30011-T4-W40	Leeds 4 Surface wall luminaires T4 Optic	1466	13.8	Standard	200x95x80mm	T4	Ra 80	4000K	IP65	0.800



Copyright:
The copyright of this drawings remains the property of DLA Architects Limited and may only be used or re-used with DLA's prior written consent.

Project:
Clandeboy Bio Mass Control Room & Amenities

Client:
Fonterra Clandeboy







Drawing Title:
Reflected Ceiling / Lighting Plan Control Room - Boilers 1&2





REV.	DATE	REVISION DETAILS
1	28/08/24	Tender Issue
0	27/05/24	First Issue

Scale: As indicated @ A3	Date: 29/08/24	Drawn: MX
Job No: C919	Designed: MA	Checked: CG
Drawing No: A2.30	Revision No: 1	

Ceiling Notes:

-  MODENA MINI LED W PREMIUM 4000K
-  Heights indicated are taken from RL0.000
-  2 Way Switch
-  PRATO Q Backlit LED Panel

Ceiling and Finishes Key:

-  **CF1 Gib Ceiling**
13mm Gib Aqualine with Rondo Gib Quiet Clip, with painted finish
-  **CF2 New Plywood Ceiling**
New 12mm plywood ceiling linings with clear varnish finish to match existing. Use adhesive and brad nails. Install 50x10 cover battens over sheet joints.
-  **CF3 Existing Timber Ceiling**
Existing timber ceiling remain unchange
-  **CF4 Proposed Grid Ceiling**
Proposed Grid Ceiling panel match the existing, fix on to existing ceiling grid.

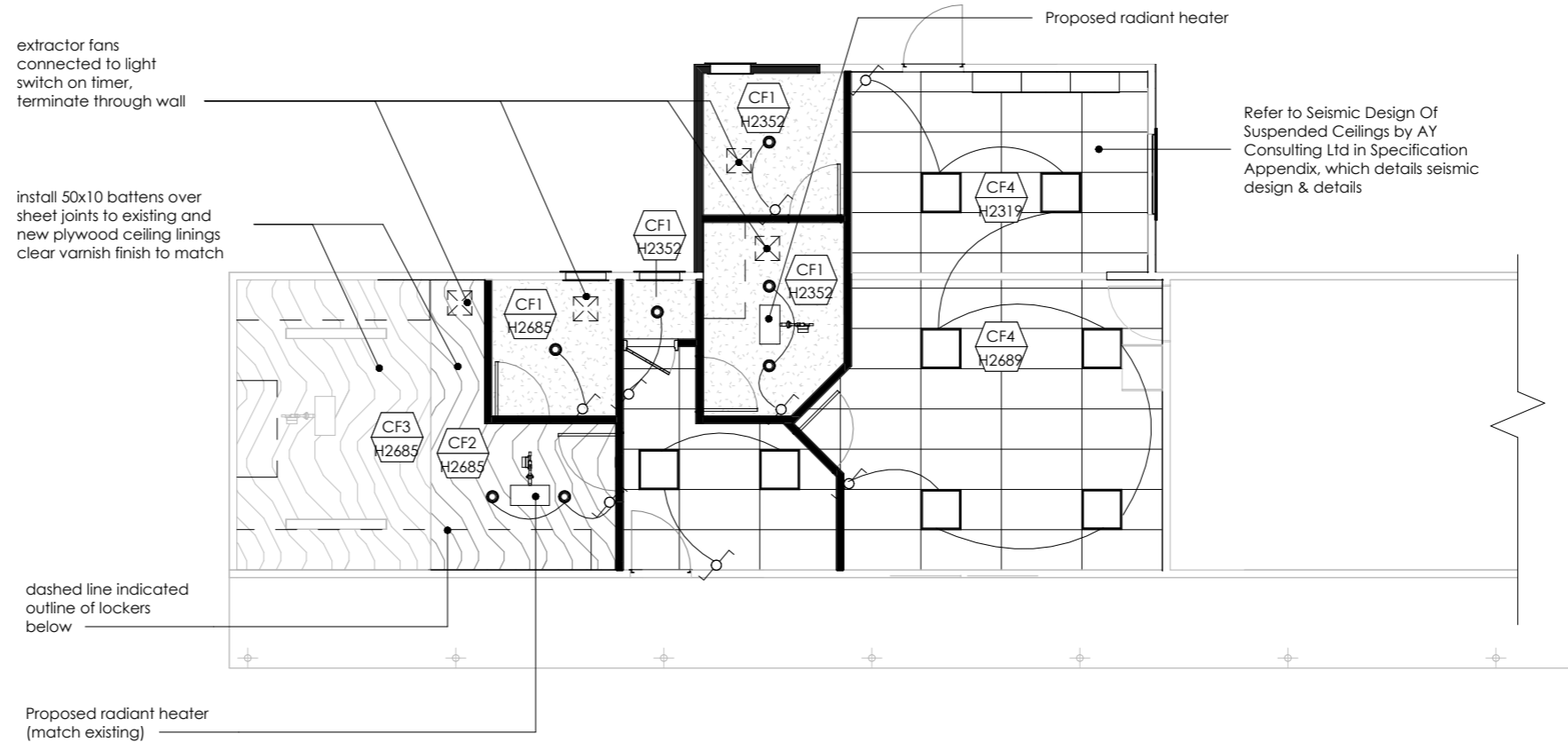

4,5&6 Reflected Ceiling / Lighting Plan

1 : 100

General Notes:

1. This drawing shall be read in conjunction with all other drawings & specifications.
2. All work shall be strictly in accordance with the New Zealand Building Code, Local Territorial Authority Requirements, OSH Requirements & Regulations, and any other Statutory Requirements that may be applicable to this project.
3. All work shall be of best trade practice.
4. Do not scale from this drawing. Use only figured dimensions. The Contractor shall verify all dimensions on site, and report any discrepancies to the Architect before commencing work.



Ceiling Finishes Notes:

1. All Plaster board wall and ceiling junctions to be square stopped.
2. Read in conjunction with mechanical and electrical drawings for all air conditioning requirements, duct, grills & lighting plans.
3. Reflected Ceiling Plans to be read in conjunction with fire design philosophy for signs etc.
4. Reflected Ceiling Plans to be read in conjunction with Colour Schedule.
5. Co-ordinate & be aware of smoke detector positions / layouts.
6. Sprinkler system to be extended.
7. Refer to Resene TechSpec in specifications for paint systems

HVAC, Fresh Air/Ventilation & Sprinkler System Note

HVAC, Fresh air, ventilation and sprinkler system to be designed by contractor and comply with all Fonterra performance requirements, building code clauses and respective design standards.

Fonterra requirements are detailed in specification appendix and must be read in conjunction with all other documentation.

Luminaire Schedule														
Project: Control Room - Boilers 4&5&6														
Symbol	Type	Qty	Manufacturer	Code	Description	Luminous Flux (lm)	Power (W)	Driver	Dimensions	Optic	CRI	CCT	IP	LLF
	B	7	PXF Lighting	EA003.1111.840.A000	MODENA MINI LED W PREMIUM 4000K	2133	18	Standard	Ø315x90mm	Opal	Ra 84	4000K	IP54	0.800
	C	8	PXF Lighting	PF5020101	PRATO Q Backlit LED Panel	3301	26	Standard	595x594x35mm	Microprismatic - 120°	Ra 80	4000K	IP44	0.800

General Notes:

1. This drawing shall be read in conjunction with all other drawings & specifications.
2. All work shall be strictly in accordance with the New Zealand Building Code, Local Territorial Authority Requirements, OSH Requirements & Regulations, and any other Statutory Requirements that may be applicable to this project.
3. All work shall be of best trade practice.
4. Do not scale from this drawing. Use only figured dimensions. The Contractor shall verify all dimensions on site, and report any discrepancies to the Architect before commencing work.



Bracing Plan Control Room - Boilers 1&2

1 : 100

REV.	DATE	REVISION DETAILS
1	28/08/24	Tender Issue
0	27/05/24	First Issue

Scale: 1 : 100 @ A3	Date: 29/08/24	Drawn: MX
Job No: C919	Designed: MA	Checked: CG
Drawing No: A2.40	Revision No: 1	

GIB EzyBrace® Bracing Software



Demand Calculation Sheet

Job Details

Name: Clandeboye Biomass Project Control Room and Amenities
 Street and Number: 26 Rolleston Road Clandeboye
 Lot and DP Number: Lot 3 DP 75226
 City/Town/District: Clandeboye
 Designer: Amos
 Company: DLA Architects
 Date: Tuesday, 2 April 2024

Building Specification

Number of Storeys: 1
 Floor Loading: 3 KPa
 Foundation Type: Slab

Single

Cladding Weight: Light
 Roof Weight: Light
 Room in Roof Space: No
 Roof Pitch (degrees): 8
 Roof Height above Eaves (m): 1.5
 Building Height to Apex (m): 4.5
 Ground to Lower Floor (m): 0.2

Average Stud Height (m): 2.7
 Building Length (m): 15
 Building Width (m): 9
 Building Plan Area (m²): 118

Building Location

Wind Zone = High
 Earthquake Zone 1
 Soil Type: D & E (Deep to Very Soft)
 Annual Prob. of Exceedance: 1 in 500 (Default)

Bracing Units required for Wind

	Along	Across
Single Level	432	619

Bracing Units required for Earthquake

	Along & Across
Single Level	301

GIB EzyBrace® Version 12/18a

GIB EzyBrace® Bracing Software



Single Level Along Resistance Sheet

Job Name: Clandeboye Biomass Project Control Room and Amenities

Wind	EQ
Demand	
432	301
Achieved	
877	759
203%	252%

Line	Element	Length (m)	Angle (degrees)	Stud Ht. (m)	Type	Supplier	Wind (BUs)	EQ (BUs)	Wind	EQ
m	1	2.50		2.7	GS1-N	GIB®	153	133		
	2	1.60		2.7	JHDn	James Hardie	168	145		
									321 OK	278 OK
n	1	2.60		2.7	JHDn	James Hardie	273	236		
	2								273 OK	236 OK
o	1	1.30		2.7	JHDn	James Hardie	136	118		
	2	1.40		2.7	JHDn	James Hardie	147	127		
									283 OK	245 OK

GIB EzyBrace® Bracing Software



Single Level Across Resistance Sheet

Job Name: Clandeboye Biomass Project Control Room and Amenities

Wind	EQ
Demand	
619	301
Achieved	
1156	1026
187%	341%

Line	Element	Length (m)	Angle (degrees)	Stud Ht. (m)	Type	Supplier	Wind (BUs)	EQ (BUs)	Wind	EQ
a	1	1.70		2.7	JHDn	James Hardie	178	154		
	2	1.30		2.7	JHDn	James Hardie	136	118		
									315 OK	272 OK
b	1	1.60		2.7	GS1-N	GIB®	98	85		
	2	3.60		2.7	GS1-N	GIB®	221	192		
									319 OK	277 OK
c	1	3.70		2.7	GS1-N	GIB®	227	197		
	2	3.10		2.7	GS1-N	GIB®	190	165		
									417 OK	363 OK
d	1	1.20		2.7	JHD	James Hardie	106	114		
	2								106 OK	114 OK

GIB EzyBrace® Bracing Software



Custom Wall Elements

Supplier	System	Min. Length m	Wind BUs/m	EQ BUs/m
James Hardie	JHDn	1.200	118	102
James Hardie	JHD	0.600	99	107

General Notes:

1. This drawing shall be read in conjunction with all other drawings & specifications.
2. All work shall be strictly in accordance with the New Zealand Building Code, Local Territorial Authority Requirements, OSH Requirements & Regulations, and any other Statutory Requirements that may be applicable to this project.
3. All work shall be of best trade practice.
4. Do not scale from this drawing. Use only figured dimensions. The Contractor shall verify all dimensions on site, and report any discrepancies to the Architect before commencing work.

Keystone Legend Per Page

Key Value	Keystone Text
43.FSR	ROOFING: Freeman Six Rib Roofing 0.55 BMT Colorcote MagnaFlow pre-finished steel trapezoidal roofing. Colour match the existing.

General Notes:

1. This drawing shall be read in conjunction with all other drawings & specifications.
2. All work shall be strictly in accordance with the New Zealand Building Code, Local Territorial Authority Requirements, OSH Requirements & Regulations, and any other Statutory Requirements that may be applicable to this project.
3. All work shall be of best trade practice.
4. Do not scale from this drawing. Use only figured dimensions. The Contractor shall verify all dimensions on site, and report any discrepancies to the Architect before commencing work.

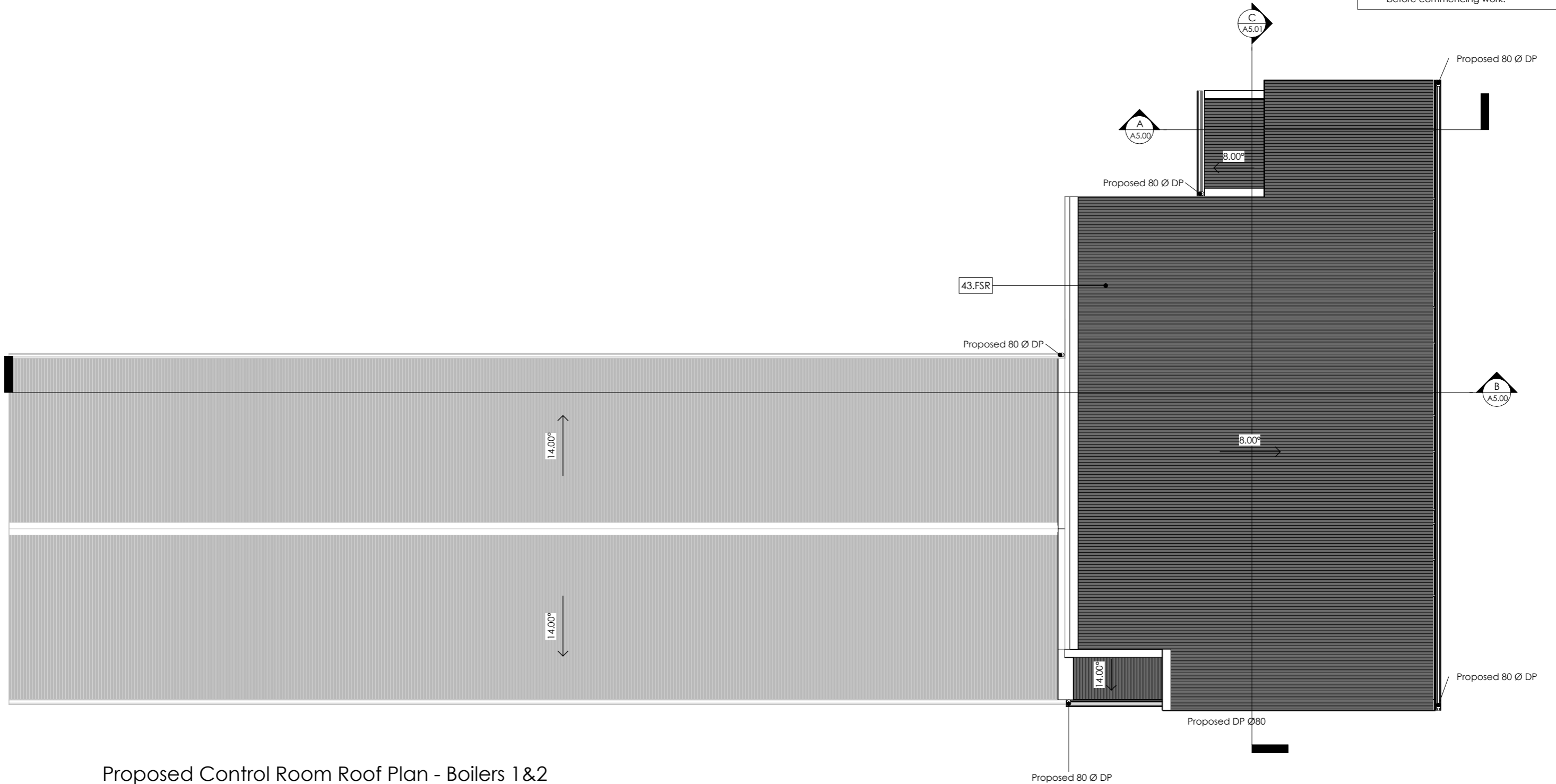

Proposed Control Room Roof Plan - Boilers 1 & 2

1 : 100

Keynote Legend Per Page

Key Value	Keynote Text
43.FSR	ROOFING: Freeman Six Rib Roofing 0.55 BMT Colorcote MagnaFlow pre-finished steel trapezoidal roofing. Colour match the existing.
43.TGU	TYPICAL GUTTER: Colorcote MagnaFlow steel 125mm Box gutter with external brackets and snow straps @ 500c/s fixed in accordance with manufacturers recommendations and colour matched to roofing.

General Notes:

1. This drawing shall be read in conjunction with all other drawings & specifications.
2. All work shall be strictly in accordance with the New Zealand Building Code, Local Territorial Authority Requirements, OSH Requirements & Regulations, and any other Statutory Requirements that may be applicable to this project.
3. All work shall be of best trade practice.
4. Do not scale from this drawing. Use only figured dimensions. The Contractor shall verify all dimensions on site, and report any discrepancies to the Architect before commencing work.

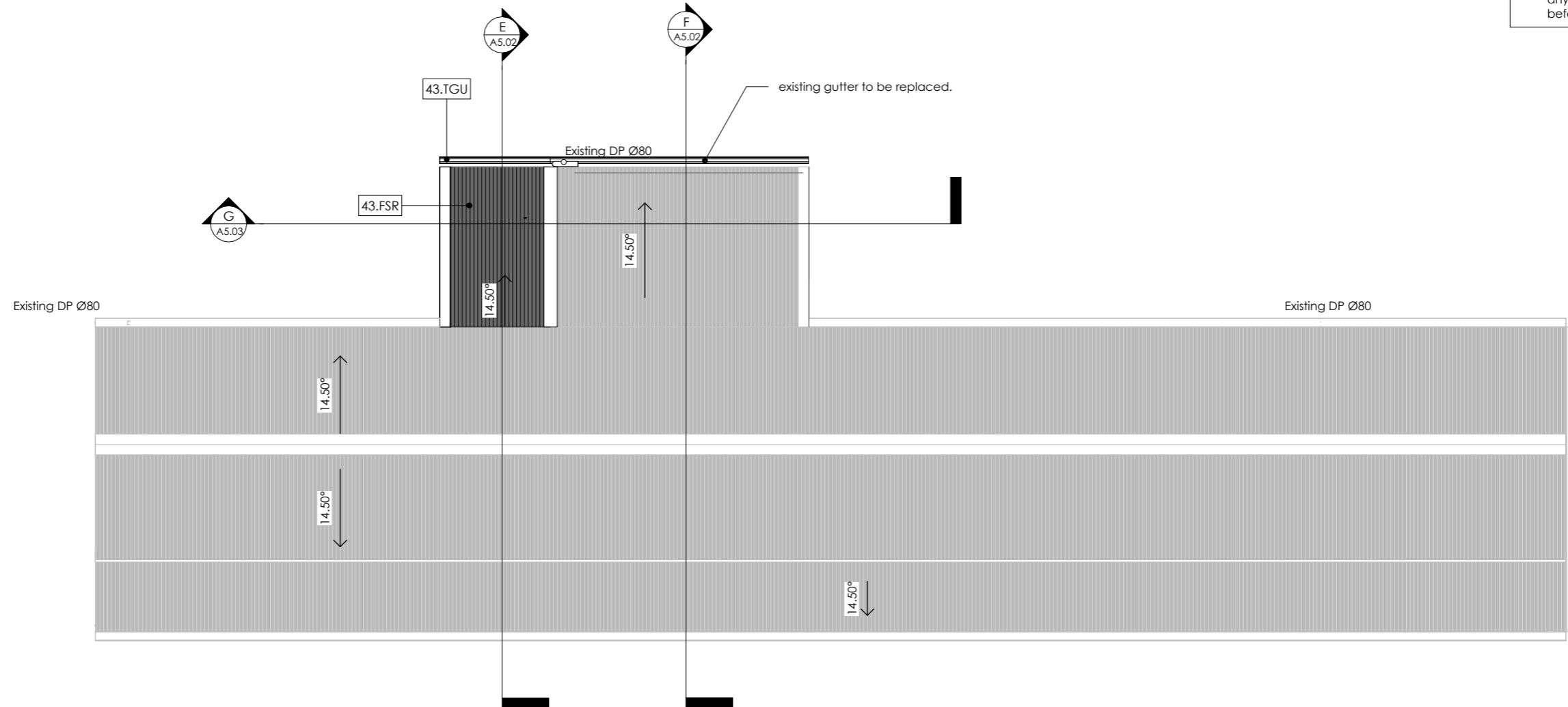

Proposed Control Room Roof Plan - Boilers 4,5&6

1 : 100

- General Notes:**
1. This drawing shall be read in conjunction with all other drawings & specifications.
 2. All work shall be strictly in accordance with the New Zealand Building Code, Local Territorial Authority Requirements, OSH Requirements & Regulations, and any other Statutory Requirements that may be applicable to this project.
 3. All work shall be of best trade practice.
 4. Do not scale from this drawing. Use only figured dimensions. The Contractor shall verify all dimensions on site, and report any discrepancies to the Architect before commencing work.

Keynote Legend Per Page	
Key Value	Keynote Text
32.RE10	REBAR: D10 rebar @400crs. supplementary reinforcing bars required at internal corner, 2 x D10, 1200m long. 50mm below slab surface to clear reinforcing.
32.REB	REBAR: D12 rebar @400crs.50mm below slab surface to clear reinforcing. lap 400 within slab mesh. 150mm epoxy-fixed into existing slab.
32.SOG	SLAB ON GROUND: 100mm thick 20mpa concrete slab reinforced with SE62 500E grade mesh over 250 micron polythene DPM.- 30mm top cover. Place concrete over 250micron polythene DPM fully lapped and sealed at all junctions in accordance with NZS3604. Protect DPM with a maximum of 25mm sand blinding on 150mm min compacted hardfill. Starter to overlap mesh by 400mm min. Mesh shall be lapped in accordance with the manufacturers specification, or a minimum of 1 square plus 50mm (as minimum requirement under nzs 3101). 5mm deep sawcuts at 6m crs and perimeter foundations.
38.TP1	TIMBER POST: Prolam 88x88mm, H5 Visual (PLPH5-100) post with 3 coat paint finish, footing size refer to detail drawing.

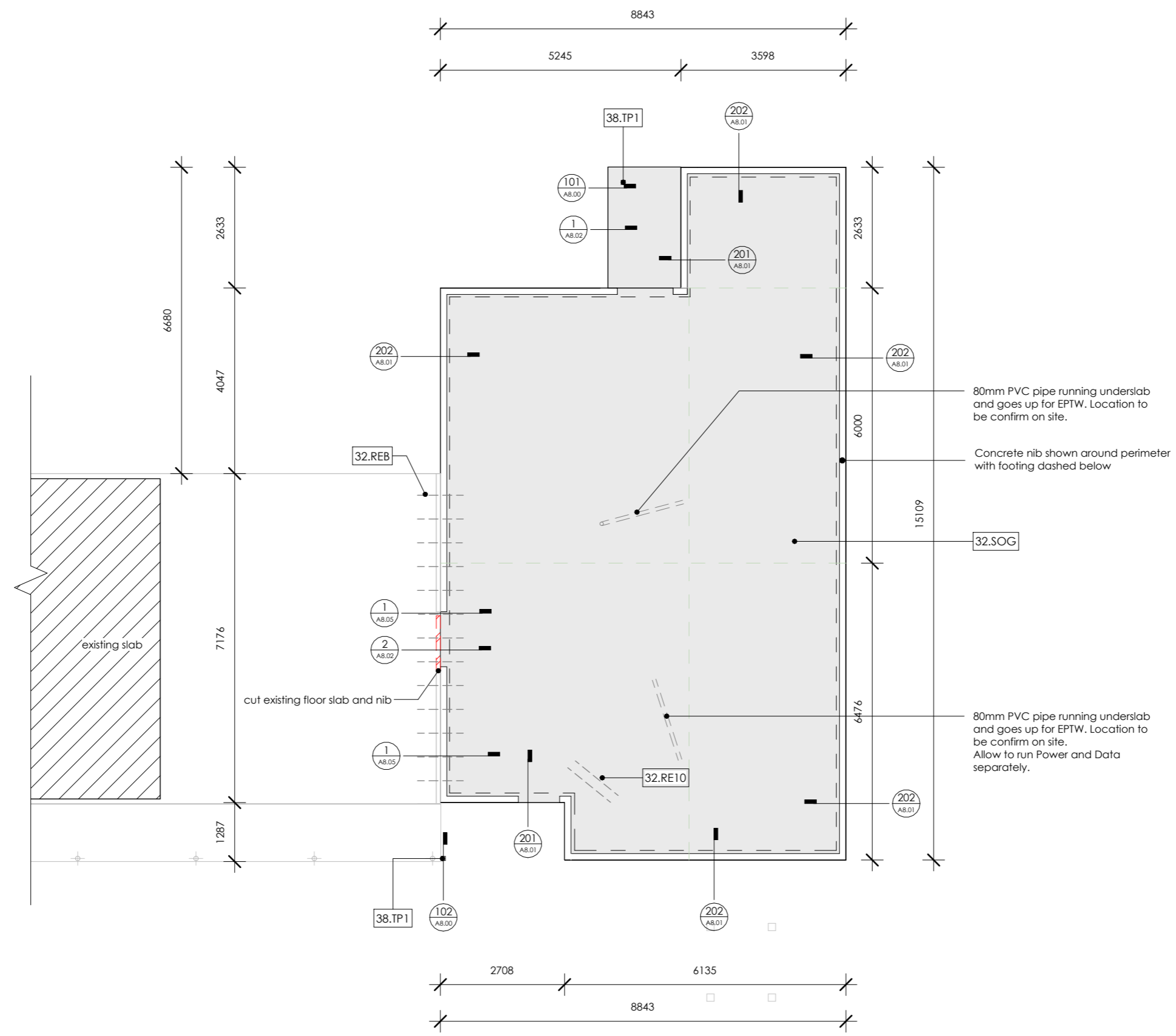

--- slab shrinkage control cuts. cut 1/4 depth into slab.

Proposed Control Room Foundation Plan - Boilers 1 & 2

1 : 100



Copyright:
The copyright of this drawings remains the property of DLA Architects Limited and may only be used or re-used with DLA's prior written consent.

Project:
Clandeboyne Bio Mass Control Room & Amenities

Client:
Fonterra Clandeboyne

Drawing Title:
Proposed Foundation Plan Control Room - Boiles 1 & 2
CAD File:

REV.	DATE	REVISION DETAILS
1	28/08/24	Tender Issue
0	27/05/24	First Issue

Scale: 1 : 100 @ A3	Date: 29/08/24	Drawn: MX
Job No: C919	Designed: MA	Checked: CG
Drawing No: A2.60	Revision No: 1	

General Notes:

1. This drawing shall be read in conjunction with all other drawings & specifications.
2. All work shall be strictly in accordance with the New Zealand Building Code, Local Territorial Authority Requirements, OSH Requirements & Regulations, and any other Statutory Requirements that may be applicable to this project.
3. All work shall be of best trade practice.
4. Do not scale from this drawing. Use only figured dimensions. The Contractor shall verify all dimensions on site, and report any discrepancies to the Architect before commencing work.

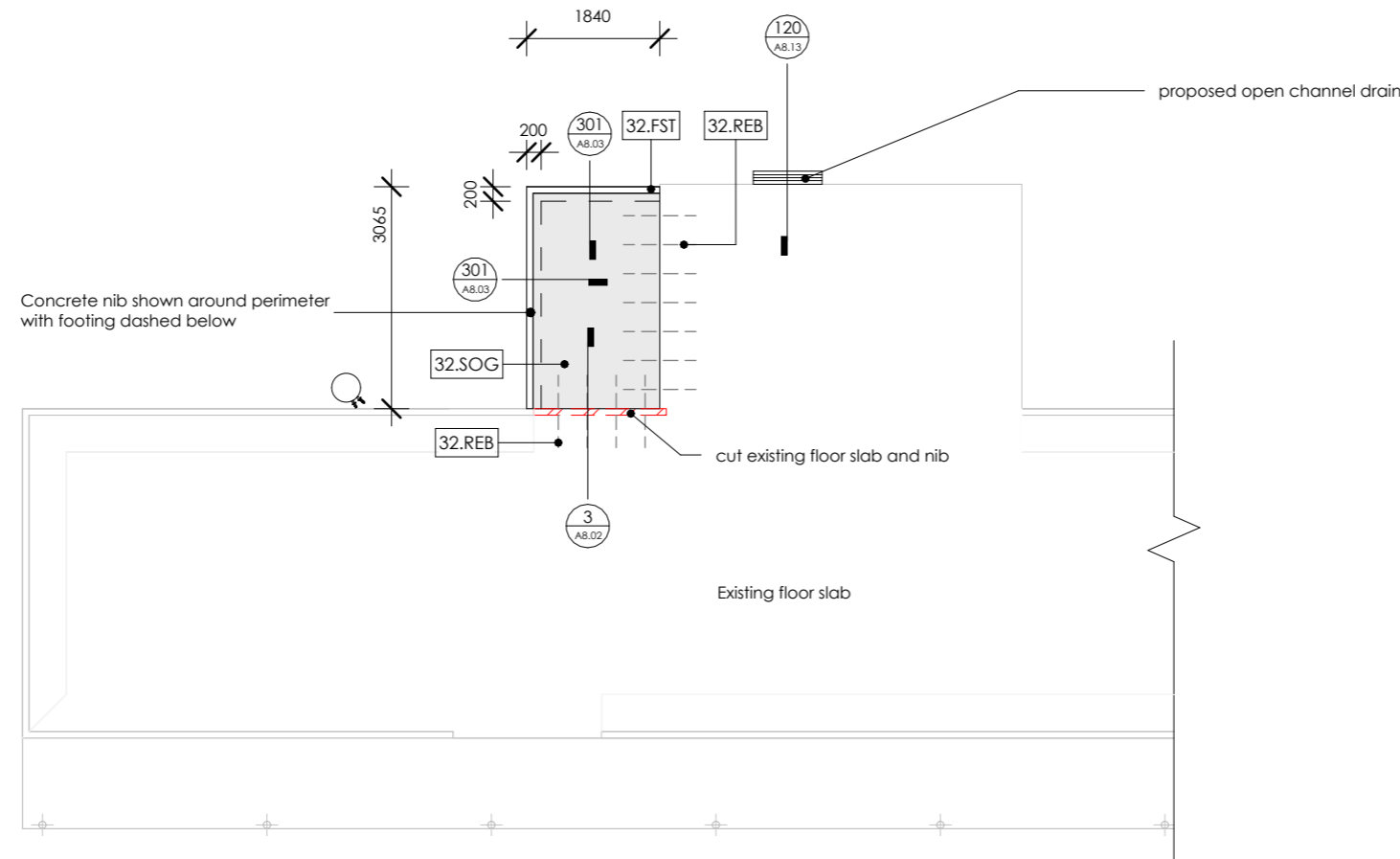

Keynote Legend Per Page

Key Value	Keynote Text
32.FST	FOOTING: Concrete footing 200mm wide down to good ground. 90mm width, 150mm height nib with scabble to slab. d10 starters @ 600crs, D10 running length of nib.
32.REB	REBAR: D12 rebar @400crs,50mm below slab surface to clear reinforcing. lap 400 within slab mesh. 150mm epoxy-fixed into existing slab.
32.SOG	SLAB ON GROUND: 100mm thick 20mpa concrete slab reinforced with SE62 500E grade mesh over 250 micron polythene DPM.- 30mm top cover. Place concrete over 250micron polythene DPM fully lapped and sealed at all junctions in accordance with NZS3604. Protect DPM with a maximum of 25mm sand blinding on 150mm min compacted hardfill. Starter to overlap mesh by 400mm min. Mesh shall be lapped in accordance with the manufacturers specification, or a minimum of 1 square plus 50mm (as minimum requirement under nzs 3101). 5mm deep sawcuts at 6m crs and perimeter foundations.

Proposed Control Room Foundation Plan - Boilers 4,5&6

1 : 100

Wall Finishes Key:

- Standard Gib**
13mm thick Standard Gib wall lining over timber wall framing, paint finish.
- GBTLA 45r Double Gib**
2 * 13mm thick Standard Gib wall lining over timber wall framing, paint finish.
- Gib Aqualine**
13mm thick Gib Aqualine wall lining over timber wall framing, paint finish.
- Paint**
Paint finish to existing wall
- Double Gib Aqualine**
2 * 13mm thick Gib Aqualine wall lining over timber wall framing, paint finish.

Keynote Legend Per Page	
Key Value	Keynote Text
32.PSL	Proposed paving slab.
38.TP1	TIMBER POST: Prolam 88x88mm, H5 Visual (PLPH5-100) post with 3 coat paint finish, footing size refer to detail drawing.
64.VS2	VINYL SURFACING 02: 2mm thick Jacobsens Tarkeff Primo Premium commercial grade floor vinyl glued and fixed in accordance with the manufacturers specification, coved 150mm unless stated otherwise. Welded joints. Refer to Colour Schedule.

General Notes:

1. This drawing shall be read in conjunction with all other drawings & specifications.
2. All work shall be strictly in accordance with the New Zealand Building Code, Local Territorial Authority Requirements, OSH Requirements & Regulations, and any other Statutory Requirements that may be applicable to this project.
3. All work shall be of best trade practice.
4. Do not scale from this drawing. Use only figured dimensions. The Contractor shall verify all dimensions on site, and report any discrepancies to the Architect before commencing work.

Wall Finishes Notes:

1. All GIB board walls to be level 4 stopped, 3 coat paint finish.
2. Acoustic Pink Batts Silencer insulation 75mm thick to all interior wall cavities Refer to Resene TechSpec in specifications for paint systems

Floor Finishes Notes:

1. Wall Finishes Plan to be read in conjunction with the Finishes Schedule.
2. Floor Finishes Plan to be read in conjunction with Joinery Details drawings for vinyl coving to joinery toe kicks, nibs etc.
3. Vinyl coving to be typically 150mm high to Amenities areas unless specified otherwise. Top of vinyl cove to be finished with aluminium trim capping **sealant bed to wall with no hairline gaps.**
4. Allow for all required skirting, nosing, threshold bars, trims etc. where necessary for all flooring.
5. Allow for all floor preparation & levelling compound to all areas as required for floor finishes.

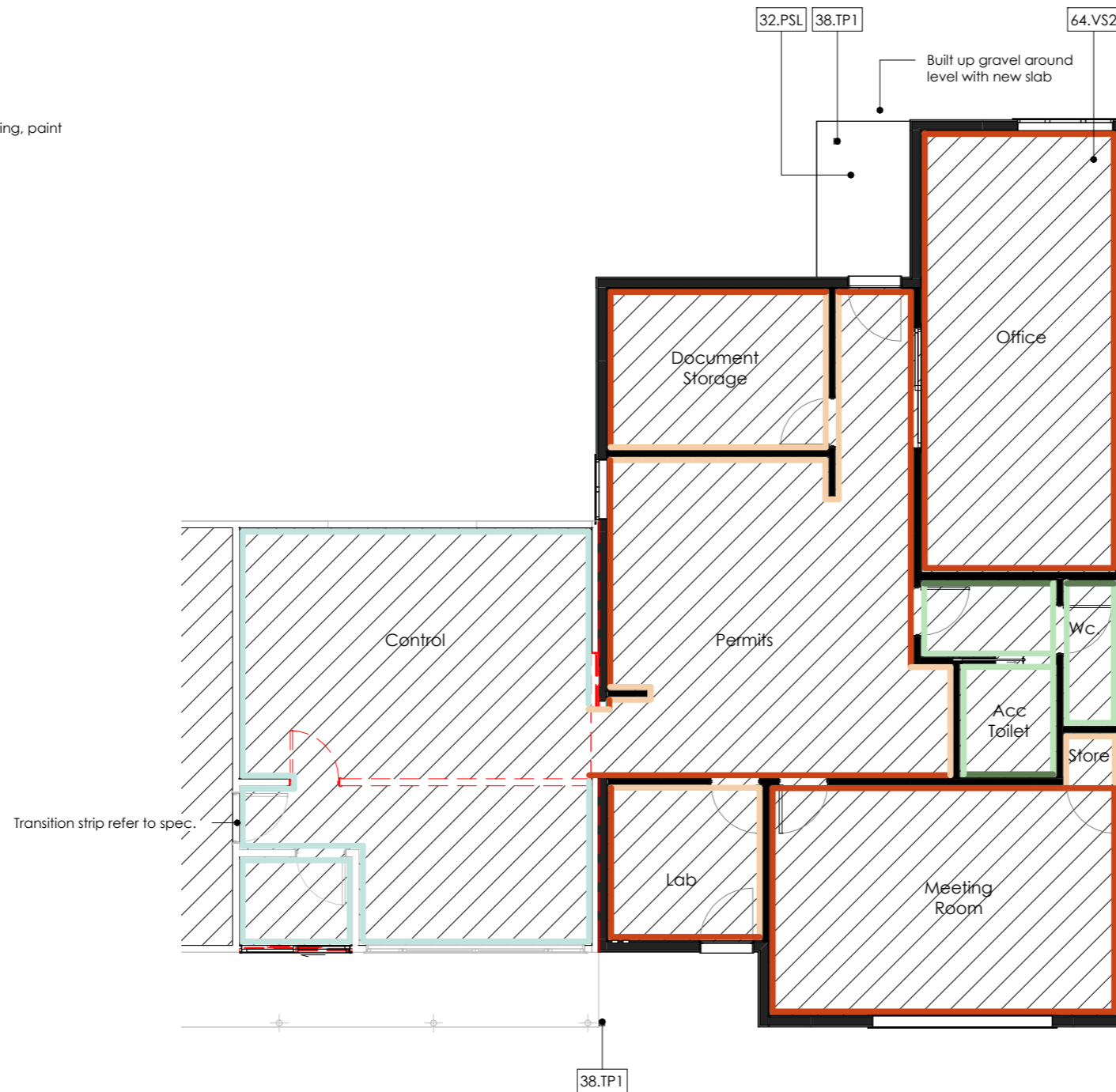

Wall & Floor Finishes Plan Control Room - Boilers 1&2

1 : 100

DRAWING NOTE:
Drawing to be printed in Colour

Wall Finishes Key:

- Standard Gib**
13mm thick Standard Gib wall lining over timber wall framing, paint finish.

- Gib Aqualine**
13mm thick Gib Aqualine wall lining over timber wall framing, paint finish.

- Plywood**
Plywood finish a line with existing

- Paint**
Paint finish to existing wall

Keynote Legend Per Page	
Key Value	Keynote Text
64.VS2	VINYL SURFACING 02: 2mm thick Jacobsens Tarkett Primo Premium commercial grade floor vinyl glued and fixed in accordance with the manufacturers specification, coved 150mm unless stated otherwise. Welded joints. Refer to Colour Schedule.
64.VS3	VINYL SURFACING 03: 2mm thick Jacobsens Tarkett Primo Safe.T NON-SLIP commercial grade floor vinyl glued and fixed in accordance with the manufacturers specification, coved 150mm unless stated otherwise. Welded Joints. Refer to Colour Schedule.

General Notes:

1. This drawing shall be read in conjunction with all other drawings & specifications.
2. All work shall be strictly in accordance with the New Zealand Building Code, Local Territorial Authority Requirements, OSH Requirements & Regulations, and any other Statutory Requirements that may be applicable to this project.
3. All work shall be of best trade practice.
4. Do not scale from this drawing. Use only figured dimensions. The Contractor shall verify all dimensions on site, and report any discrepancies to the Architect before commencing work.

Wall Finishes Notes:

1. All GIB board walls to be level 4 stopped, 3 coat paint finish.
2. Acoustic Pink Batts Silencer insulation 75mm thick to all interior wall cavities
3. Refer to Resene TechSpec in specifications for paint systems

Floor Finishes Notes:

1. Wall Finishes Plan to be read in conjunction with the Finishes Schedule.
2. Floor Finishes Plan to be read in conjunction with Joinery Details drawings for vinyl coving to joinery toe kicks, nibs etc.
3. Vinyl coving to be typically 150mm high to Amenities areas unless specified otherwise. Top of vinyl cove to be finished with aluminium trim capping **sealant bed to wall with no hairline gaps.**
4. Allow for all required skirting, nosing, threshold bars, trims etc where necessary for all flooring.
5. Allow for all floor preparation & levelling compound to all areas as required for floor finishes.

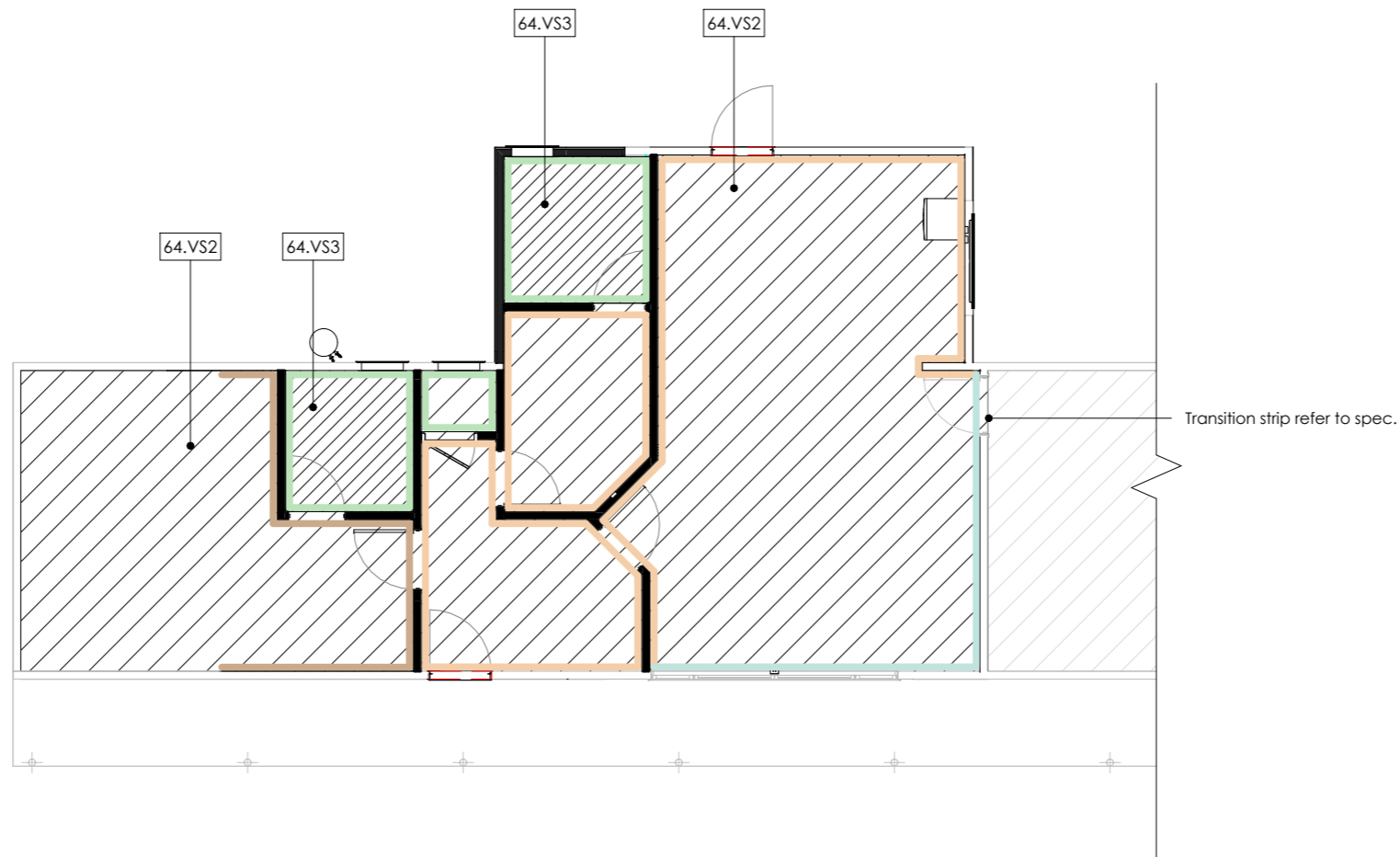

Wall & Floor Finishes Plan Control Room- Boilers 4,5&6

1 : 100

DRAWING NOTE:
Drawing to be printed in Colour

- General Notes:**
1. This drawing shall be read in conjunction with all other drawings & specifications.
 2. All work shall be strictly in accordance with the New Zealand Building Code, Local Territorial Authority Requirements, OSH Requirements & Regulations, and any other Statutory Requirements that may be applicable to this project.
 3. All work shall be of best trade practice.
 4. Do not scale from this drawing. Use only figured dimensions. The Contractor shall verify all dimensions on site, and report any discrepancies to the Architect before commencing work.

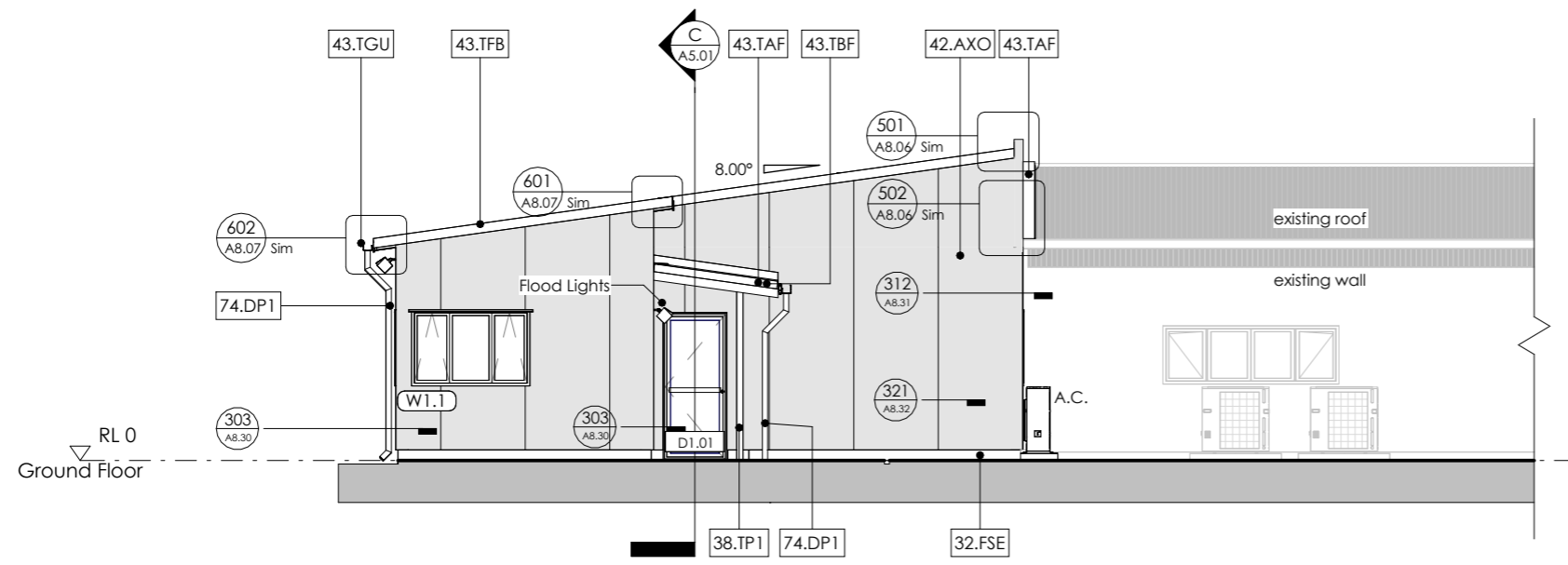

Proposed Elevation North - Boilers 1 & 2

1 : 100

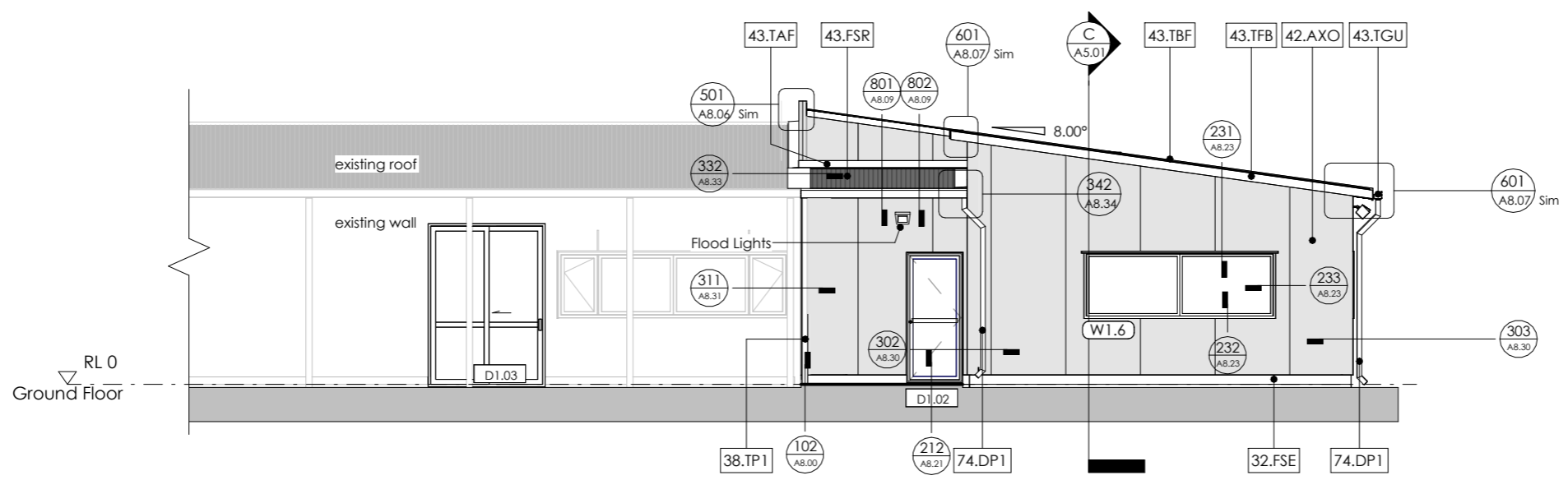

Proposed Elevation South - Boilers 1 & 2

1 : 100

Control Room 1,2 Amenities - Building Envelope Risk...

Risk Factor	Risk Factor	Risk Score
NORTH ELEVATION		
Wind Zone (per NZS 3604)	H	1
Number of Storeys	1	0
Roof / Wall Intersections	High	3
Eaves Width	High	2
Envelope Complexity	Low	0
Deck Design	Low	0
Total Risk Score		6
EAST ELEVATION		
Wind Zone (per NZS 3604)	H	1
Number of Storeys	1	0
Roof / Wall Intersections	High	3
Eaves Width	Very High	3
Envelope Complexity	Low	0
Deck Design	Low	0
Total Risk Score		7
SOUTH ELEVATION		
Wind Zone (per NZS 3604)	H	1
Number of Storeys	1	0
Roof / Wall Intersections	High	3
Eaves Width	High	2
Envelope Complexity	Low	0
Deck Design	Low	0
Total Risk Score		6
WEST ELEVATION		
Wind Zone (per NZS 3604)	H	1
Number of Storeys	1	0
Roof / Wall Intersections	High	3
Eaves Width	Very High	3
Envelope Complexity	Low	0
Deck Design	Low	0
Total Risk Score		7

Keynote Legend Per Page

Key Value	Keynote Text
32.FSE	FOOTING: Concrete footing 200mm wide down to good ground. 140mm width, 150mm height nib with scabble to slab. d10 starters @ 600crs, D10 running length of nib.
38.TP1	TIMBER POST: Prolam 88x88mm, H5 Visual (PLPH5-100) post with 3 coat paint finish, footing size refer to detail drawing.
42.AXO	AXON Panel: 9mm thick x 1200mm wide Axon Panel, over CLD cavity battens fixed to wall framing, over RAB board to new timber wall framing. To be installed in accordance with Axon Panel Technical Specification. Coat paint finish to match existing cladding, unless noted otherwise.
43.FSR	ROOFING: Freeman Six Rib Roofing 0.55 BMT Colorcote MagnaFlow pre-finished steel trapezoidal roofing. Colour match the existing.
43.TAF	TYPICAL APRON FLASHING: 0.55mm BMT Colorcote MagnaFlow apron flashings complete with hem. 75mm min. cover to over flashing, 110mm total height. over flashing w/ 35mm min. clearance to apron flashing. refer to cladding notes for material type.
43.TBF	TYPICAL METAL BARGE FLASHING: 0.55 BMT Colorcote MagnaFlow (matching colour as roof cladding) Barge flashing lapped over roof cladding. lap min. 2 crests.
43.TFB	TYPICAL METAL FASCIA/BARGE BOARD 147mm: 0.55BMT Colorcote MagnaFlow formed steel fascia with clips fixed to framing. Colorcote MagnaFlow gutters packed off fascia with 6mm gap behind.
43.TGU	TYPICAL GUTTER: Colorcote MagnaFlow steel 125mm Box gutter with external brackets and snow straps @ 500crs fixed in accordance with manufacturers recommendations and colour matched to roofing.
74.DP1	DOWNPIPES: 80dia. Colorcote MagnaFlow downpipes with pipe brackets @ 1200crs and maintenance gap to riser with leaf grate



Copyright:
The copyright of this drawings remains the property of DLA Architects Limited and may only be used or re-used with DLA's prior written consent.

Project:
Clandeboy Bio Mass Control Room & Amenities

Client:
Fonterra Clandeboy

Drawing Title:
Control Room - Boilers 1 & 2 Elevations North & South
CAD File:

REV.	DATE	REVISION DETAILS
1	28/08/24	Tender Issue
0	27/05/24	First Issue

Scale: 1 : 100 @ A3	Date: 29/08/24	Drawn: MX
Job No: C919	Designed: MA	Checked: CG
Drawing No: A4.00	Revision No: 1	

General Notes:

1. This drawing shall be read in conjunction with all other drawings & specifications.
2. All work shall be strictly in accordance with the New Zealand Building Code, Local Territorial Authority Requirements, OSH Requirements & Regulations, and any other Statutory Requirements that may be applicable to this project.
3. All work shall be of best trade practice.
4. Do not scale from this drawing. Use only figured dimensions. The Contractor shall verify all dimensions on site, and report any discrepancies to the Architect before commencing work.

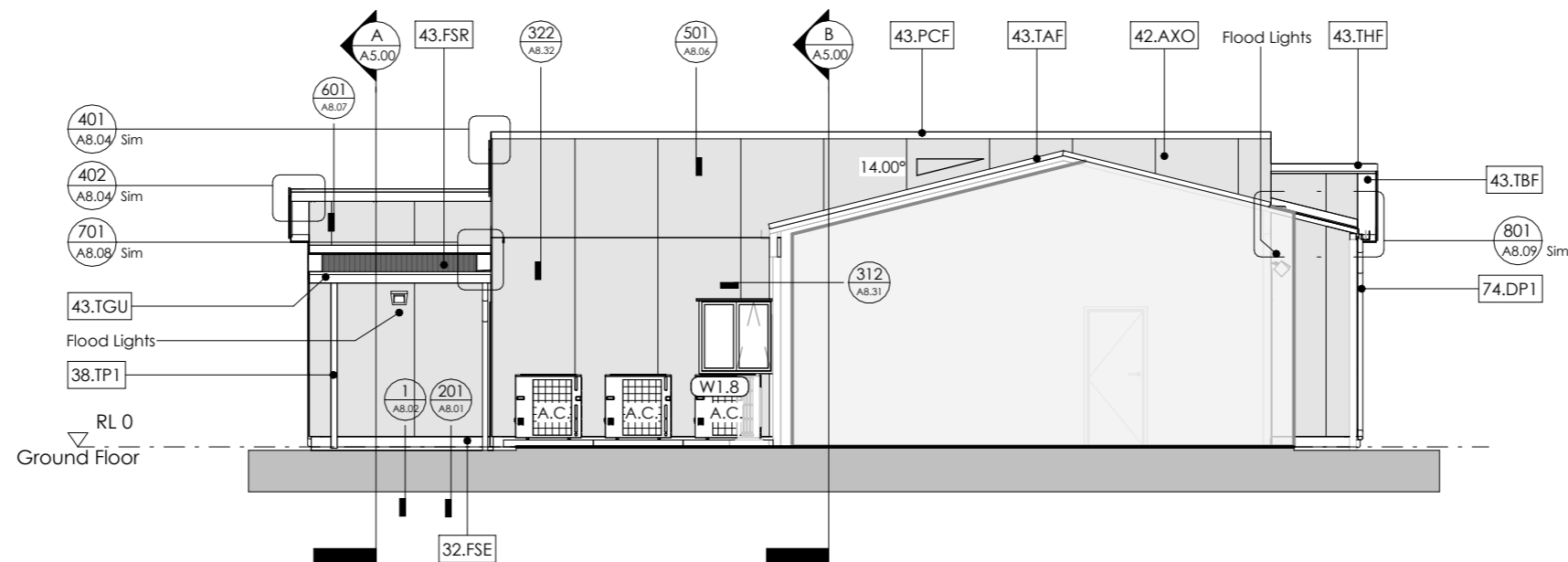

Proposed Elevation West - Boilers 1 & 2

1 : 100

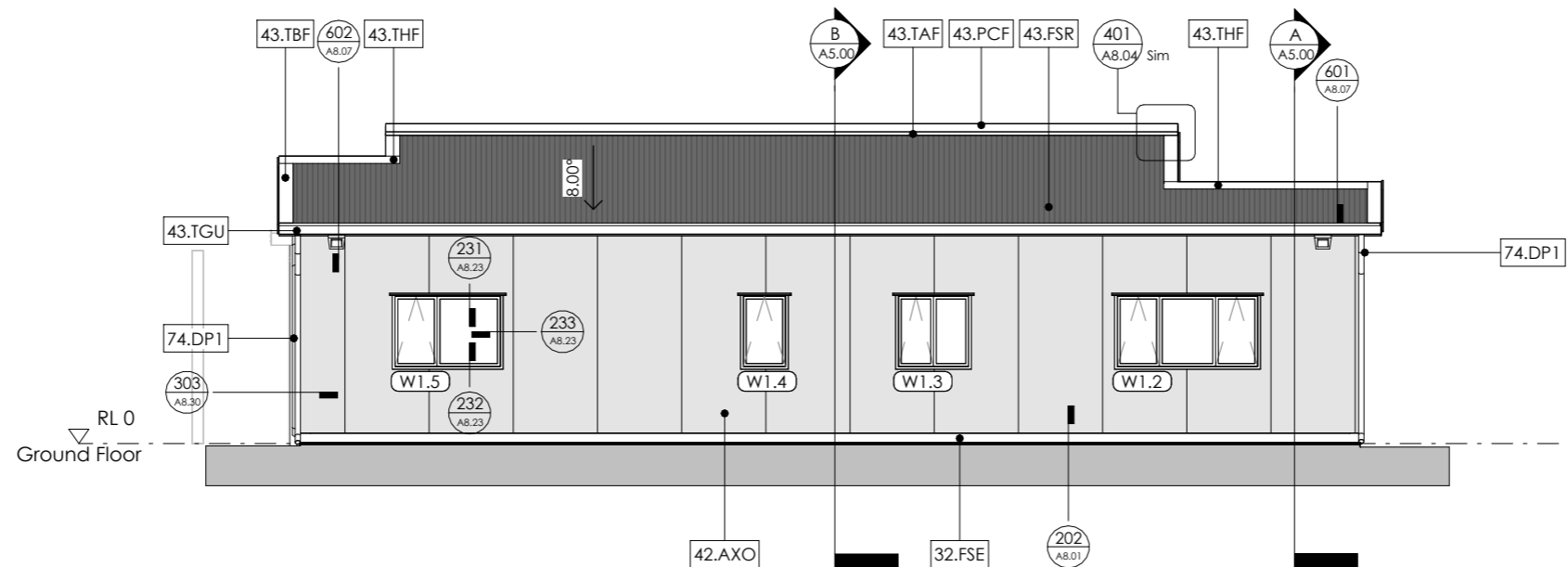

Proposed Elevation East - Boilers 1 & 2

1 : 100

Keynote Legend Per Page

Key Value	Keynote Text
32.FSE	FOOTING: Concrete footing 200mm wide down to good ground. 140mm width, 150mm height nib with scabble to slab, d10 starters @ 600crs, D10 running length of nib.
38.TP1	TIMBER POST: Prolam 88x88mm, H5 Visual (PLPH5-100) post with 3 coat paint finish, footing size refer to detail drawing.
42.AXO	AXON Panel: 9mm thick x 1200mm wide Axon Panel, over CLD cavity battens fixed to wall framing, over RAB board to new timber wall framing. To be installed in accordance with Axon Panel Technical Specification. Coat paint finish to match existing cladding, unless noted otherwise.
43.FSR	ROOFING: Freeman Six Rib Roofing 0.55 BMT Colorcote MagnaFlow pre-finished steel trapezoidal roofing. Colour match the existing.
43.PCF	CAP FLASHING: 0.55BMT Colorcote MagnaFlow pre-finished parapet cap flashing
43.TAF	TYPICAL APRON FLASHING: 0.55mm BMT Colorcote MagnaFlow apron flashings complete with hem. 75mm min. cover to over flashing, 110mm total height. over flashing w/ 35mm min. clearance to apron flashing. refer to cladding notes for material type.
43.TBF	TYPICAL METAL BARGE FLASHING: 0.55 BMT Colorcote MagnaFlow (matching colour as roof cladding) Barge flashing lapped over roof cladding, lap min. 2 crests.
43.TGU	TYPICAL GUTTER: Colorcote MagnaFlow steel 125mm Box gutter with external brackets and snow straps @ 500crs fixed in accordance with manufacturers recommendations and colour matched to roofing.
43.THF	TYPICAL HEAD FLASHING: 0.55mm BMT Colorcote MagnaFlow head flashings. 70mm min. cover to over flashing.
74.DP1	DOWNPIPES: 80dia. Colorcote MagnaFlow downpipes with pipe brackets @ 1200crs and maintenance gap to riser with leaf grate



Copyright:
The copyright of this drawings remains the property of DLA Architects Limited and may only be used or re-used with DLA's prior written consent.

Project:
Clandeboy Bio Mass Control Room & Amenities

Client:
Fonterra Clandeboy

Drawing Title:
Control Room - Boilers 1 & 2 Elevations West & East
CAD File:

REV.	DATE	REVISION DETAILS
1	28/08/24	Tender Issue
0	27/05/24	First Issue

Scale: 1 : 100 @ A3	Date: 29/08/24	Drawn: MX
Job No: C919	Designed: MA	Checked: CG
Drawing No: A4.01	Revision No: 1	

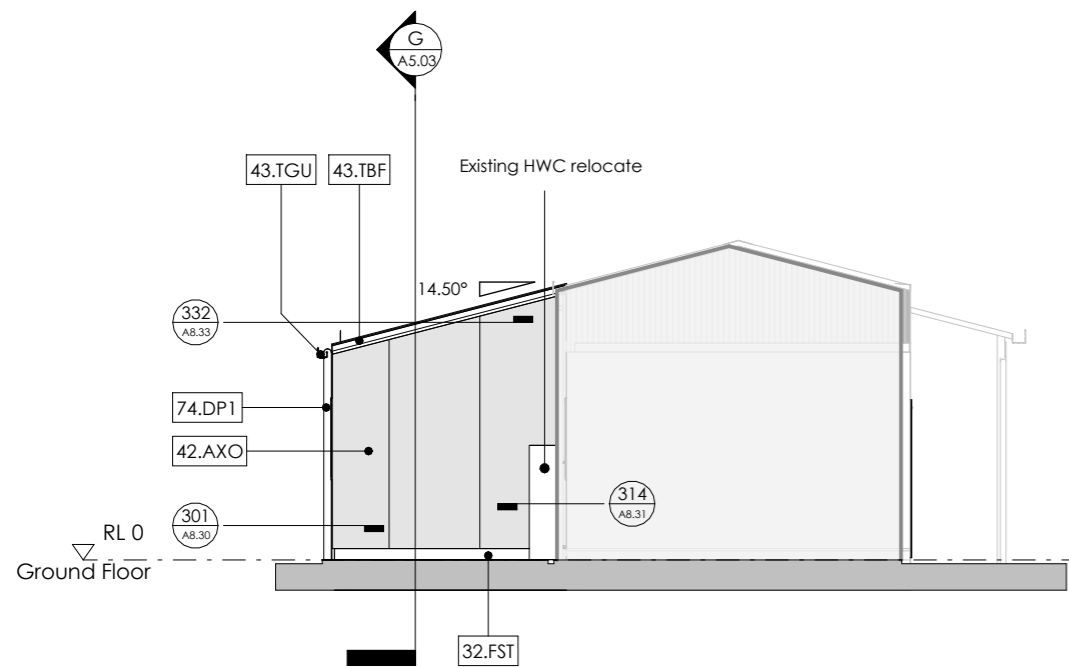

4,5&6 Proposed Elevation West - Boilers 4,5&6

1 : 100

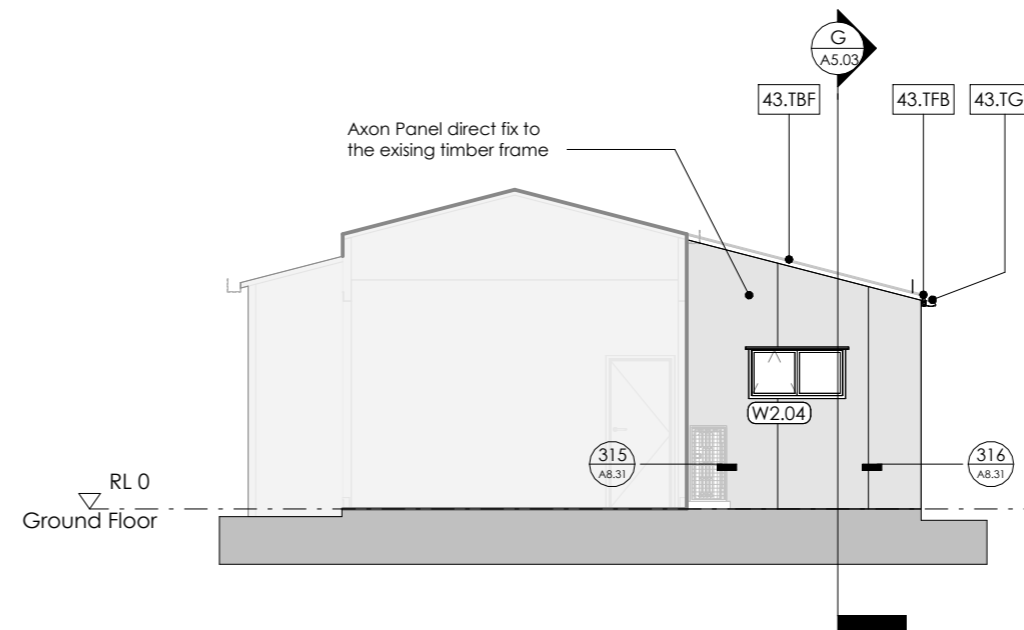

4,5&6 Proposed Elevation East - Boilers 4,5&6

1 : 100

General Notes:

1. This drawing shall be read in conjunction with all other drawings & specifications.
2. All work shall be strictly in accordance with the New Zealand Building Code, Local Territorial Authority Requirements, OSH Requirements & Regulations, and any other Statutory Requirements that may be applicable to this project.
3. All work shall be of best trade practice.
4. Do not scale from this drawing. Use only figured dimensions. The Contractor shall verify all dimensions on site, and report any discrepancies to the Architect before commencing work.

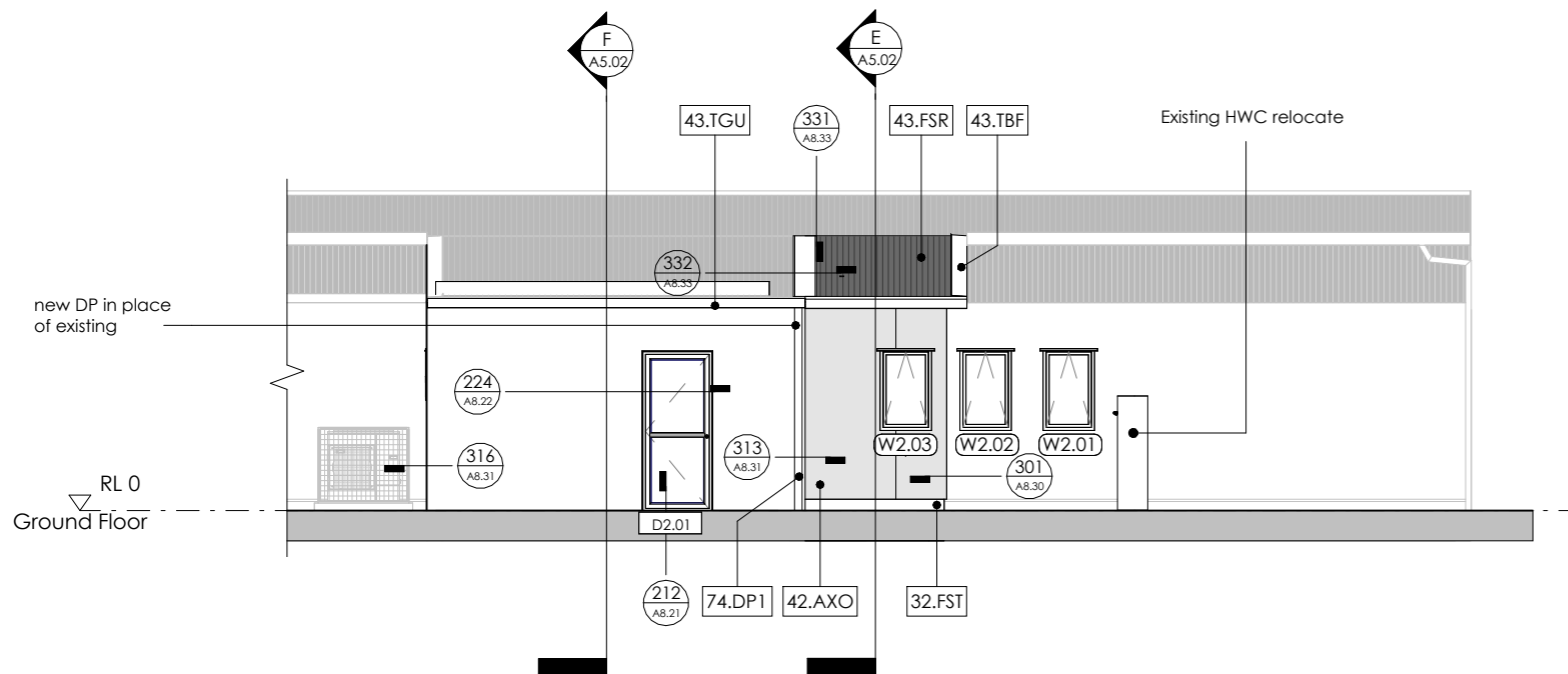

4,5&6 Proposed Elevation North - Boilers 4,5&6

1 : 100

Control Room 4,5,6 Amenities - Building Envelope Risk...

Risk Factor	Risk Factor	Risk Score
NORTH ELEVATION		
Wind Zone (per NZS 3604)	H	1
Number of Storeys	1	0
Roof / Wall Intersections	Med	2
Eaves Width	Very High	3
Envelope Complexity	Low	0
Deck Design	Low	0
Total Risk Score		6
EAST ELEVATION		
Wind Zone (per NZS 3604)	H	1
Number of Storeys	1	0
Roof / Wall Intersections	Med	2
Eaves Width	Very High	3
Envelope Complexity	Low	0
Deck Design	Low	0
Total Risk Score		6
WEST ELEVATION		
Wind Zone (per NZS 3604)	H	1
Number of Storeys	1	0
Roof / Wall Intersections	Med	2
Eaves Width	Very High	3
Envelope Complexity	Low	0
Deck Design	Low	0
Total Risk Score		6

Keynote Legend Per Page

Key Value	Keynote Text
32.FST	FOOTING: Concrete footing 200mm wide down to good ground. 90mm width, 150mm height nib with scabbles to slab, d10 starters @ 600crs, D10 running length of nib.
42.AXO	AXON Panel: 9mm thick x 1200mm wide Axon Panel, over CLD cavity battens fixed to wall framing, over RAB board to new timber wall framing. To be installed in accordance with Axon Panel Technical Specification. Coat paint finish to match existing cladding, unless noted otherwise.
43.FSR	ROOFING: Freeman Six Rib Roofing 0.55 BMT Colorcote MagnaFlow pre-finished steel trapezoidal roofing. Colour match the existing.
43.TBF	TYPICAL METAL BARGE FLASHING: 0.55 BMT Colorcote MagnaFlow (matching colour as roof cladding) Barge flashing lapped over roof cladding, lap min. 2 crests.
43.TFB	TYPICAL METAL FASCIA/BARGE BOARD 147mm: 0.55BMT Colorcote MagnaFlow formed steel fascia with clips fixed to framing. Colorcote MagnaFlow gutters packed off fascia with 6mm gap behind.
43.TGU	TYPICAL GUTTER: Colorcote MagnaFlow steel 125mm Box gutter with external brackets and snow straps @ 500crs fixed in accordance with manufacturers recommendations and colour matched to roofing.
74.DP1	DOWNPIPES: 80dia. Colorcote MagnaFlow downpipes with pipe brackets @ 1200crs and maintenance gap to riser with leaf grate

Keynote Legend Per Page

Key Value	Keynote Text
32.FSE	FOOTING: Concrete footing 200mm wide down to good ground. 140mm width, 150mm height nib with scabble to slab, d10 starters @ 600crs, D10 running length of nib.
32.PSL	Proposed paving slab.
32.SLB	SLAB ON GROUND: 100mm thick 20mpa concrete slab reinforced with SE62 500E grade mesh over 25mm micron polythene DPM.
37.ETB	BEAM: 150 x 45mm timber beam.
37.ETI	STRINGER: 140 x 45mm timber stringer.
38.ETF1	EXTERNAL TIMBER FRAMING: 140 x 45mm, H1.2 studs at 600mm centres max.
38.ITF	INTERNAL TIMBER FRAMING: Construct with 90mm x 45mm SG8 h1.2 framing with studs @ 600mm crs to nzs3604:2011. Dwang at 800mmcrs. Dwang for all fittings, fixtures, linings, bracing panels & trims. DPC between bottom plate and conc. Slab.
38.RTP	TIMBER PURLINS: 70x45mm SG8 H1.2 treated timber purlins with 900mm spacing, max fixed with 1/10g Self-drilling screw, 80mm long, at each rafter/truss.
38.TP1	TIMBER POST: Prolam 88x88mm, H5 Visual (PLPH5-100) post with 3 coat paint finish, footing size refer to detail drawing.
38.TTC	TIMBER TRUSS CONSTRUCTION: Timber trusses @ 900 crs generally designed, fabricated and fixed according to the engineered truss design and specifications.
42.AXO	AXON Panel: 9mm thick x 1200mm wide Axon Panel, over CLD cavity battens fixed to wall framing, over RAB board to new timber wall framing. To be installed in accordance with Axon Panel Technical Specification. Coat paint finish to match existing cladding, unless noted otherwise.
43.FSR	ROOFING: Freeman Six Rib Roofing 0.55 BMT Colorcote MagnaFlow pre-finished steel trapezoidal roofing. Colour match the existing.
43.JHS	JAMES HARDIE SOFFIT LINING: 6mm prefinished Villaboard Eaves soffit lining and pvc jointers with painted finish
43.TAF	TYPICAL APRON FLASHING: 0.55mm BMT Colorcote MagnaFlow apron flashings complete with hem, 75mm min. cover to over flashing, 110mm total height, over flashing w/ 35mm min. clearance to apron flashing, refer to cladding notes for material type.
43.TFA	TYPICAL FASCIA/BARGE BOARD 185mm: 0.55BMT Colorcote MagnaFlow formed steel fascia with clips fixed to framing. Colorcote MagnaFlow gutters packed off fascia with 6mm gap behind.
43.TFB	TYPICAL METAL FASCIA/BARGE BOARD 147mm: 0.55BMT Colorcote MagnaFlow formed steel fascia with clips fixed to framing. Colorcote MagnaFlow gutters packed off fascia with 6mm gap behind.
43.TGU	TYPICAL GUTTER: Colorcote MagnaFlow steel 125mm Box gutter with external brackets and snow straps @ 500crs fixed in accordance with manufacturers recommendations and colour matched to roofing.
43.TRF	TYPICAL RIDGE FLASHING: 0.55mm BMT Colorcote MagnaFlow ridge flashings complete with control/slip joint.
47.INR	Pink Batts Roof insulation 275mm.
47.INW	Pink Batts wall insulation 90mm.
53.GCL	GIB BOARD CEILING LINING: 13mm Standary GIB board ceiling lining, level 4 GIB stopping and 3 coat paint finish, supported by rondo suspended ceiling grid system. Refer to Colour Schedule.
53.GCL2	Double GIB Quiet ceiling.
53.RQC	RONDO QUIET CLIP fixed to truss bottom chords
64.VS2	VINYL SURFACING 02: 2mm thick Jacobsens Tarkett Primo Premium commercial grade floor vinyl glued and fixed in accordance with the manufacturers specification, covered 150mm unless stated otherwise. Welded joints. Refer to Colour Schedule.
74.DP1	DOWNPIPES: 80dia. Colorcote MagnaFlow downpipes with pipe brackets @ 1200crs and maintenance gap to riser with leaf grate

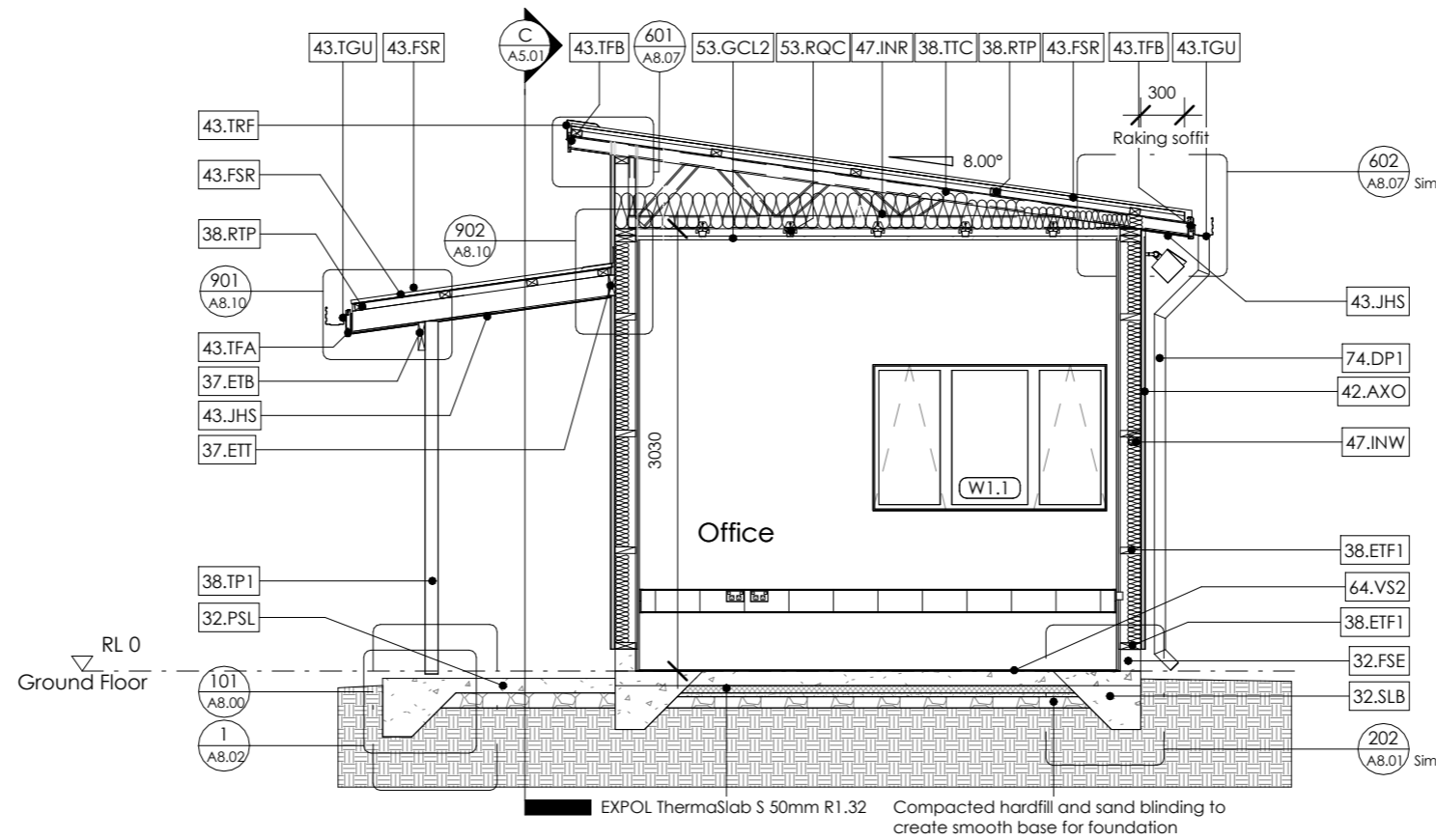

Section A

1 : 50

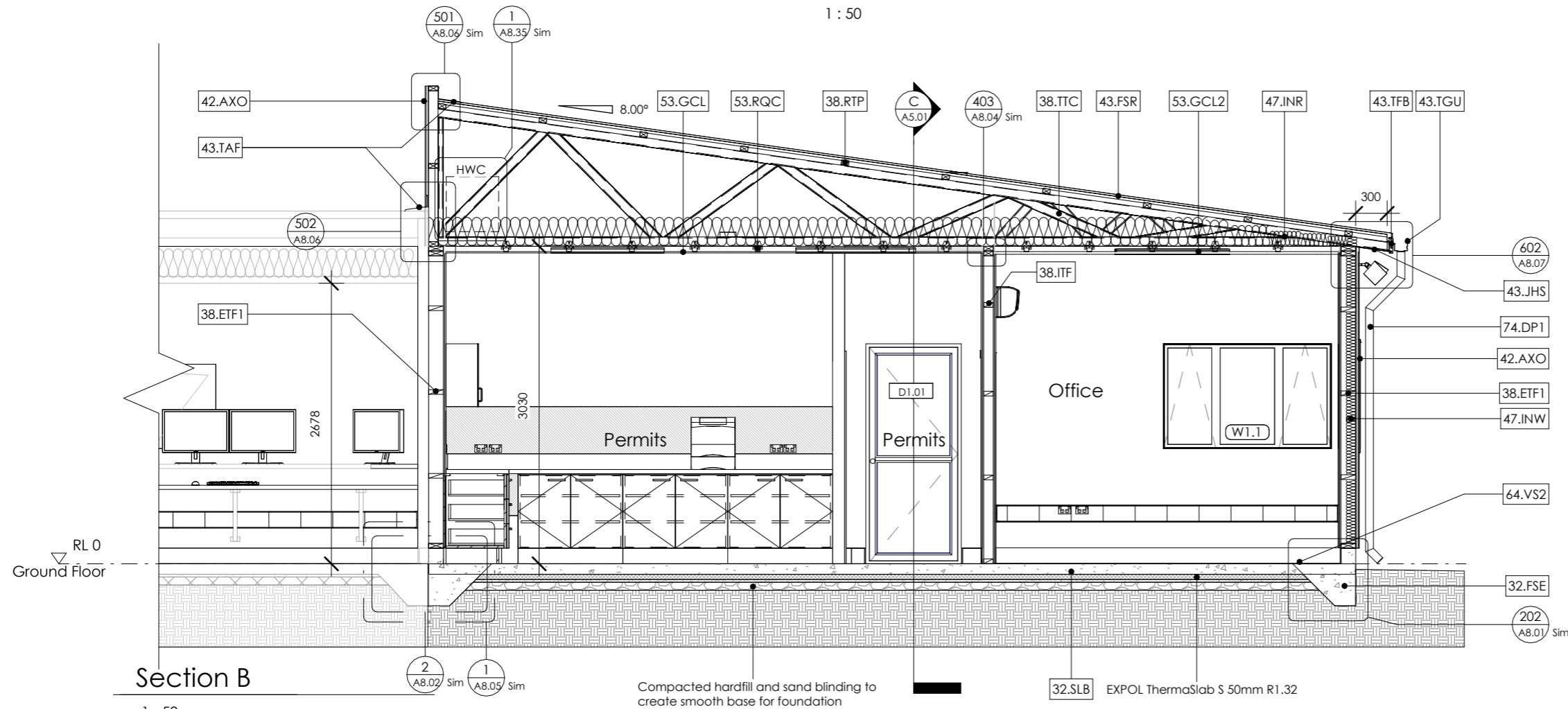

Section B

1 : 50



Copyright:
The copyright of this drawings remains the property of DLA Architects Limited and may only be used or re-used with DLA's prior written consent.

Project:
Clandeboye Bio Mass Control Room & Amenities

Client:
Fonterra Clandeboye

Drawing Title:
Control Room - Boilers 1&2 Section A & B
CAD File:

REV.	DATE	REVISION DETAILS
1	28/08/24	Tender Issue
0	27/05/24	First Issue

Scale: 1 : 50 @ A3	Date: 29/08/24	Drawn: MX
Job No: C919	Designed: MA	Checked: CG
Drawing No: A5.00	Revision No: 1	

Keynote Legend Per Page

Key Value	Keynote Text
32.FSE	FOOTING: Concrete footing 200mm wide down to good ground. 140mm width, 150mm height nib with scabble to slab, d10 starters @ 600crs, D10 running length of nib.
32.SLB	SLAB ON GROUND: 100mm thick 20mpa concrete slab reinforced with SE62 500E grade mesh over 250 micron polythene DPM.
38.ETF1	EXTERNAL TIMBER FRAMING: 140 x 45mm, H1.2 studs at 600mm centres max.
38.ITF	INTERNAL TIMBER FRAMING: Construct with 90mm x 45mm SG8 h1.2 framing with studs @ 600mm crs to nzs3604:2011. Dwang at 800mmcrs. Dwang for all fittings, fixtures, linings, bracing panels & trims. DPC between bottom plate and conc. Slab.
38.TTC	TIMBER TRUSS CONSTRUCTION: Timber trusses @ 900 crs generally designed, fabricated and fixed according to the engineered truss design and specifications.
38.TTT	TIMBER TRUSS: timber end truss to take cladding.
42.AXO	AXON Panel: 9mm thick x 1200mm wide Axon Panel, over CLD cavity battens fixed to wall framing, over RAB board to new timber wall framing. To be installed in accordance with Axon Panel Technical Specification. Coat paint finish to match existing cladding, unless noted otherwise.
43.FSR	ROOFING: Freeman Six Rib Roofing 0.55 BMT Colorcote MagnaFlow pre-finished steel trapezoidal roofing. Colour match the existing.
43.JHS	JAMES HARDIE SOFFIT LINING: 6mm prefinished Villaboard Eaves soffit lining and pvc jointers with painted finish
43.TBF	TYPICAL METAL BARGE FLASHING: 0.55 BMT Colorcote MagnaFlow (matching colour as roof cladding) Barge flashing lapped over roof cladding, lap min. 2 crests.

Keynote Legend Per Page

Key Value	Keynote Text
43.TFB	TYPICAL METAL FASCIA/BARGE BOARD 147mm: 0.55BMT Colorcote MagnaFlow formed steel fascia with clips fixed to framing. Colorcote MagnaFlow gutters packed off fascia with 6mm gap behind.
47.INR	Pink Batts Roof insulation 275mm.
51.HGL	13mm GIB Standard interior wall lining, level 4 plaster and paint finish
51.QGL	GBTLA 45r Double 13mm GIB Standard interior wall lining, level 4 plaster and paint finish.
52.SSO	SOCKET: Switched socket outlets.
53.GCL	GIB BOARD CEILING LINING: 13mm Standary GIB board ceiling lining, level 4 GIB stopping and 3 coat paint finish, supported by rondo suspended ceiling grid system. Refer to Colour Schedule.
53.GCL2	Double GIB Quiet ceiling.
64.VS2	VINYL SURFACING 02: 2mm thick Jacobsens Tarkett Primo Premium commercial grade floor vinyl glued and fixed in accordance with the manufacturers specification, coved 150mm unless stated otherwise. Welded joints. Refer to Colour Schedule.

General Notes:

1. This drawing shall be read in conjunction with all other drawings & specifications.
2. All work shall be strictly in accordance with the New Zealand Building Code, Local Territorial Authority Requirements, OSH Requirements & Regulations, and any other Statutory Requirements that may be applicable to this project.
3. All work shall be of best trade practice.
4. Do not scale from this drawing. Use only figured dimensions. The Contractor shall verify all dimensions on site, and report any discrepancies to the Architect before commencing work.

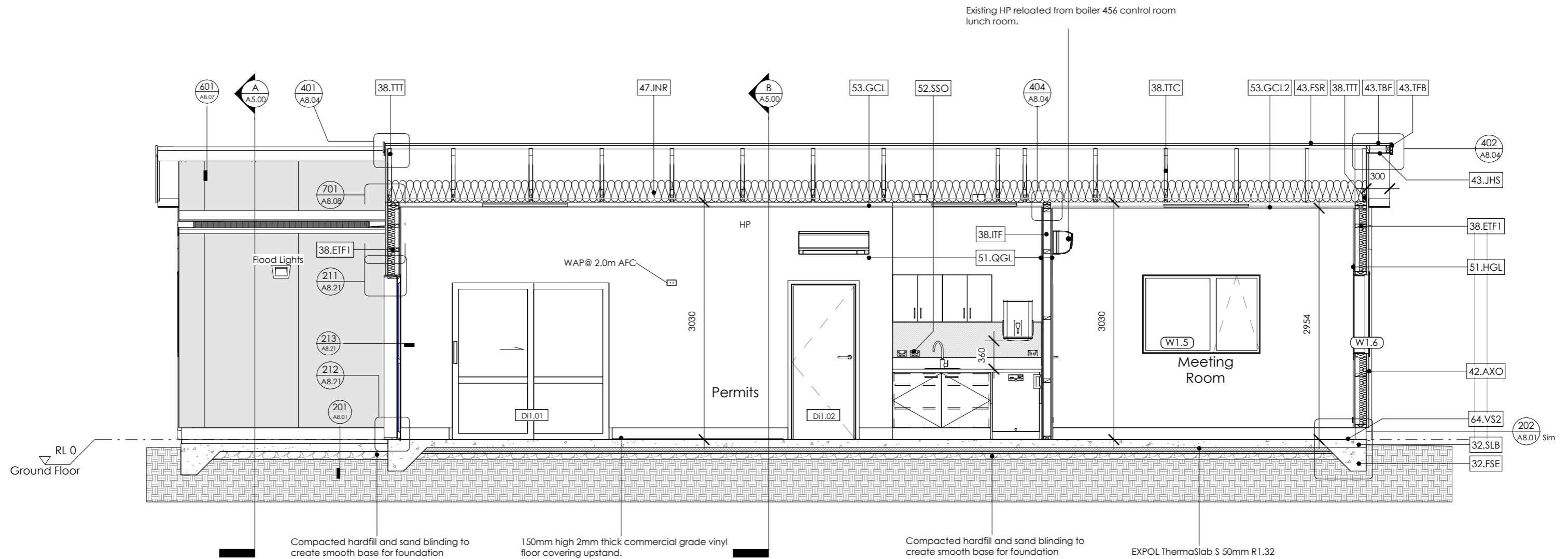

Section C

1 : 50

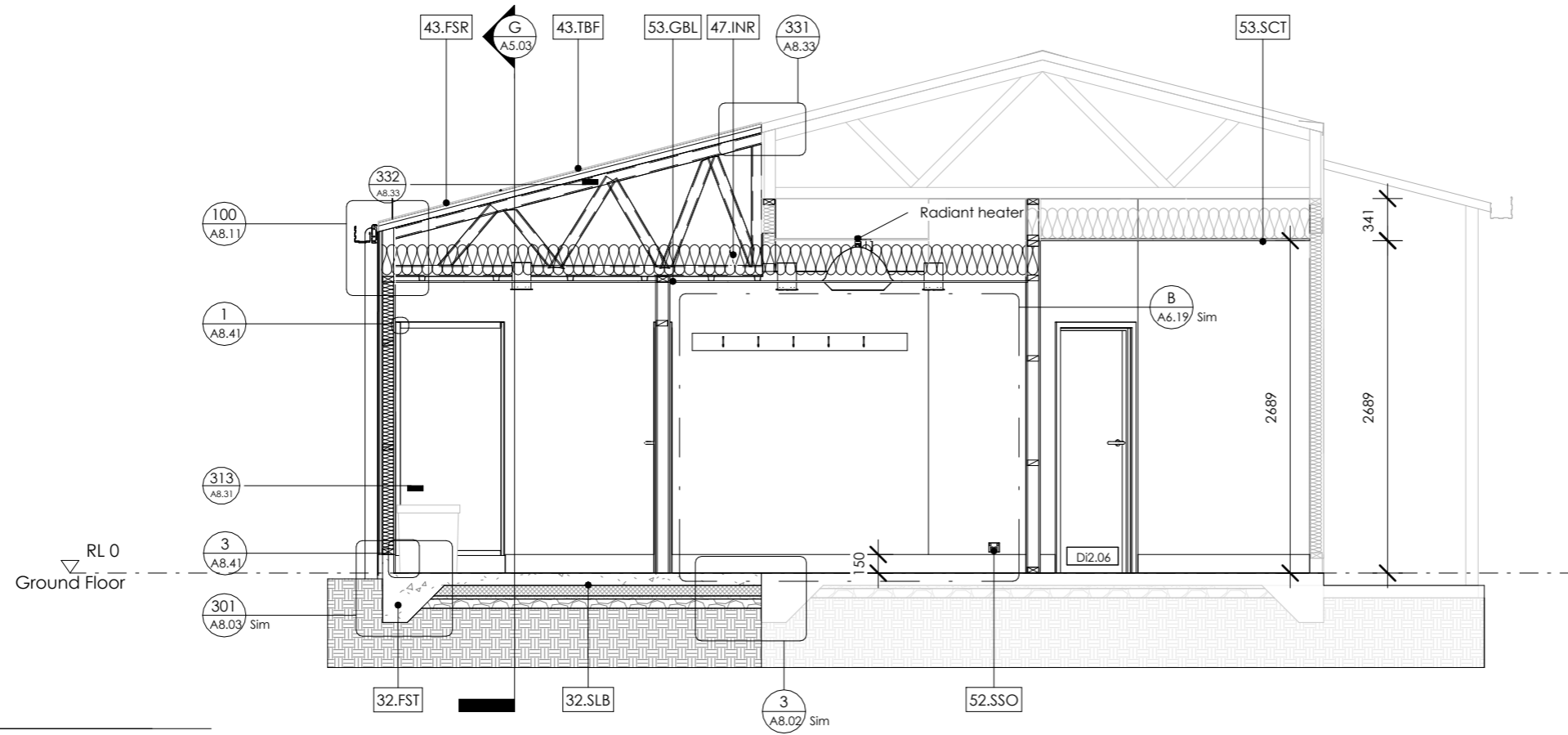

Section E

1 : 50

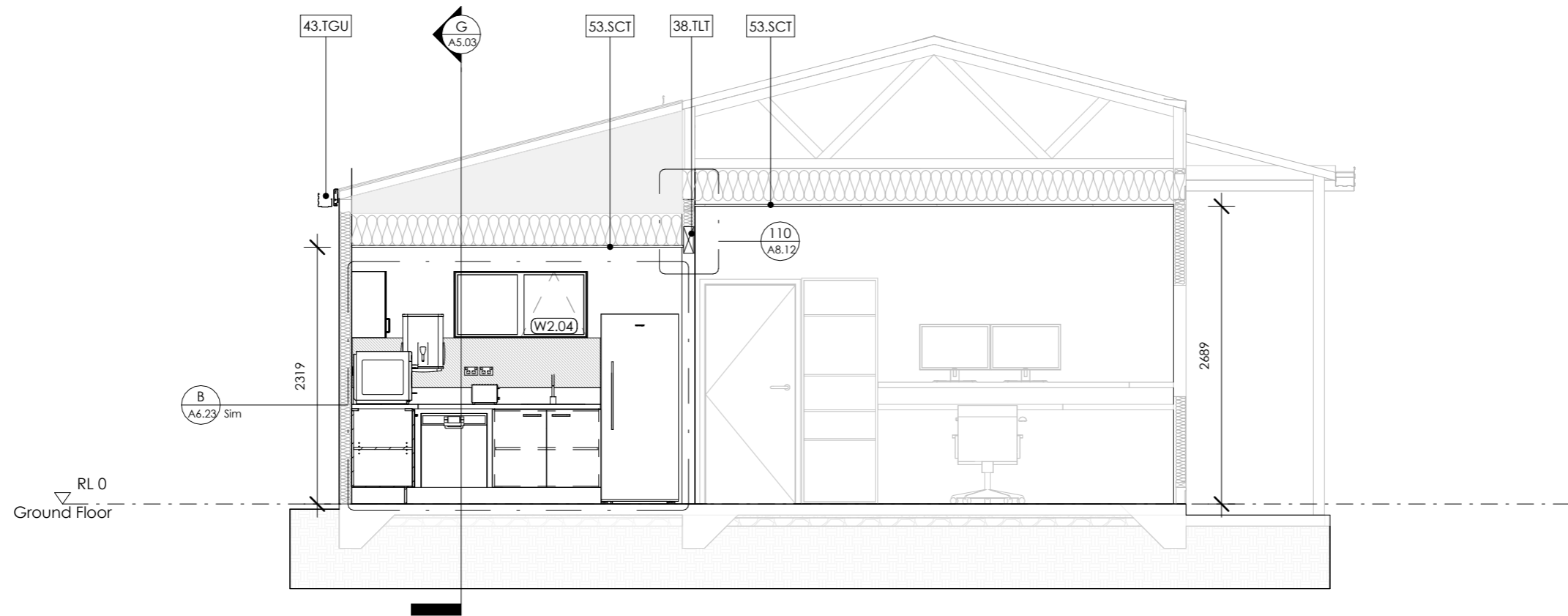

Section F

1 : 50

General Notes:

1. This drawing shall be read in conjunction with all other drawings & specifications.
2. All work shall be strictly in accordance with the New Zealand Building Code, Local Territorial Authority Requirements, OSH Requirements & Regulations, and any other Statutory Requirements that may be applicable to this project.
3. All work shall be of best trade practice.
4. Do not scale from this drawing. Use only figured dimensions. The Contractor shall verify all dimensions on site, and report any discrepancies to the Architect before commencing work.

Keystone Legend Per Page

Key Value	Keystone Text
32.FST	FOOTING: Concrete footing 200mm wide down to good ground. 90mm width, 150mm height nib with scabble to slab, d10 starters @ 600crs, D10 running length of nib.
32.SLB	SLAB ON GROUND: 100mm thick 20mpa concrete slab reinforced with SE62 500E grade mesh over 250 micron polythene DPM.
38.TLT	LINTEL: 240 x 90mm LVL Futurebuild H1.2 Lintel. Fix to wall framing with MiTek Lumberlok Lintel Fixing TYPE H.
43.FSR	ROOFING: Freeman Six Rib Roofing 0.55 BMT Colorcote MagnaFlow pre-finished steel trapezoidal roofing. Colour match the existing.
43.TBF	TYPICAL METAL BARGE FLASHING: 0.55 BMT Colorcote MagnaFlow (matching colour as roof cladding) Barge flashing lapped over roof cladding, lap min. 2 crests.
43.TGU	TYPICAL GUTTER: Colorcote MagnaFlow steel 125mm Box gutter with external brackets and snow straps @ 500crs fixed in accordance with manufacturers recommendations and colour matched to roofing.
47.INR	Pink Batts Roof insulation 275mm.
52.SSO	SOCKET: Switched socket outlets.
53.GBL	GIB BOARD CEILING LINING: 13mm Aqualine GIB board ceiling lining, level 4 GIB stopping and 3 coat paint finish, supported by rondo suspended ceiling grid system. Refer to Colour Schedule.
53.SCT	SUSPENDED CEILING TILES: 1200 x 600 x 16mm Armstrong Fine Fissured RH99, NRC0.60 CAC35 acoustic ceiling, square lay-in a 2-way Armstrong 24mm Peakform suspended grid system. Refer to Colour Schedule.

Keystone Legend Per Page

Key Value	Keystone Text
32.FST	FOOTING: Concrete footing 200mm wide down to good ground. 90mm width, 150mm height nib with scabble to slab, d10 starters @ 600crs, D10 running length of nib.
43.FSR	ROOFING: Freeman Six Rib Roofing 0.55 BMT Colorcote MagnaFlow pre-finished steel trapezoidal roofing. Colour match the existing.
43.JHS	JAMES HARDIE SOFFIT LINING: 6mm prefinished Villaboard Eaves soffit lining and pvc jointers with painted finish
43.TBF	TYPICAL METAL BARGE FLASHING: 0.55 BMT Colorcote MagnaFlow (matching colour as roof cladding) Barge flashing lapped over roof cladding, lap min. 2 crests.
43.TFB	TYPICAL METAL FASCIA/BARGE BOARD 147mm: 0.55BMT Colorcote MagnaFlow formed steel fascia with clips fixed to framing. Colorcote MagnaFlow gutters packed off fascia with 6mm gap behind.
47.INR	Pink Batts Roof insulation 275mm.
53.SCT	SUSPENDED CEILING TILES: 1200 x 600 x 16mm Armstrong Fine Fissured RH99, NRC0.60 CAC35 acoustic ceiling, square lay-in a 2-way Armstrong 24mm Peakform suspended grid system. Refer to Colour Schedule.

General Notes:

1. This drawing shall be read in conjunction with all other drawings & specifications.
2. All work shall be strictly in accordance with the New Zealand Building Code, Local Territorial Authority Requirements, OSH Requirements & Regulations, and any other Statutory Requirements that may be applicable to this project.
3. All work shall be of best trade practice.
4. Do not scale from this drawing. Use only figured dimensions. The Contractor shall verify all dimensions on site, and report any discrepancies to the Architect before commencing work.

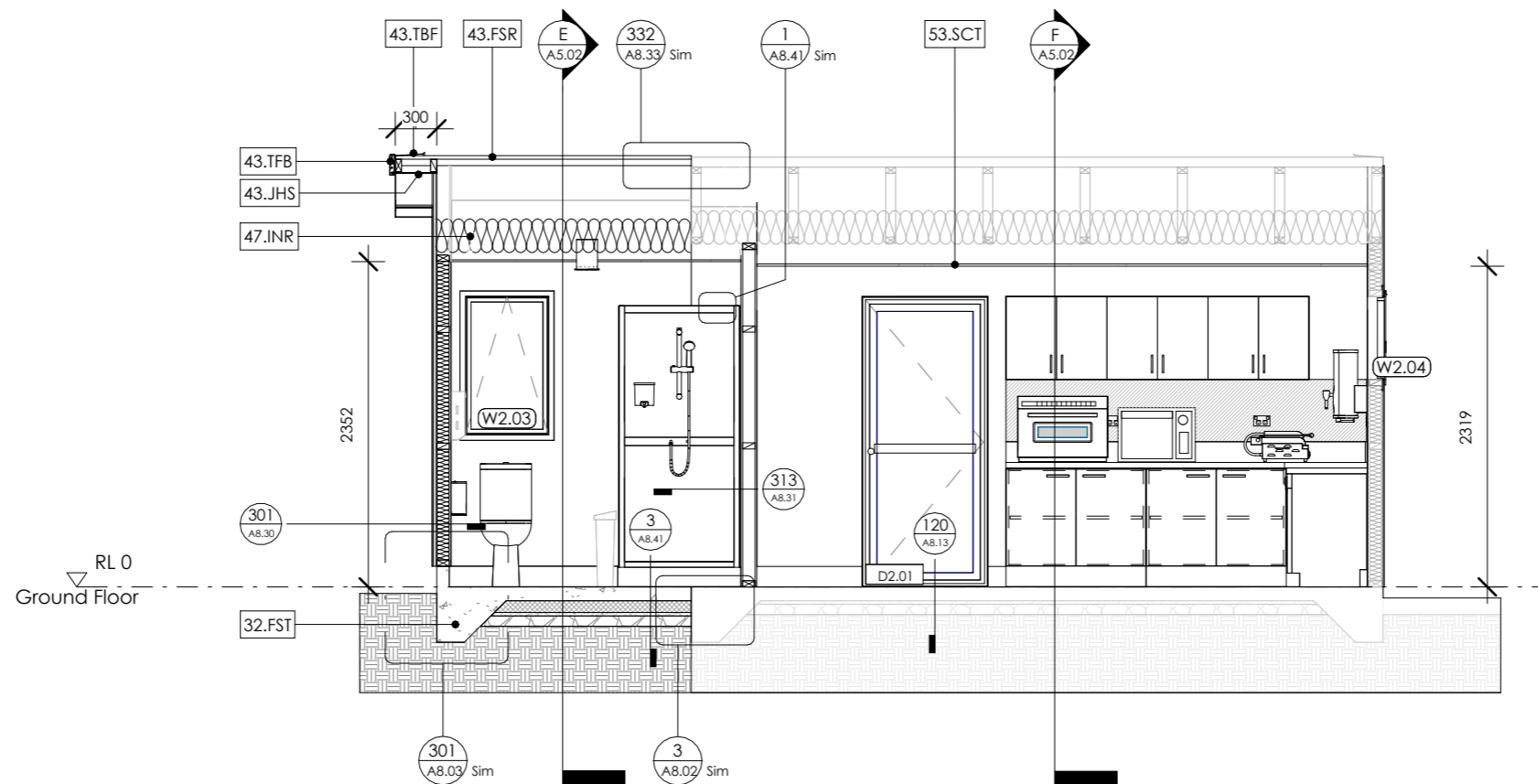

Section G

1 : 50

General Notes:

1. This drawing shall be read in conjunction with all other drawings & specifications.
2. All work shall be strictly in accordance with the New Zealand Building Code, Local Territorial Authority Requirements, OSH Requirements & Regulations, and any other Statutory Requirements that may be applicable to this project.
3. All work shall be of best trade practice.
4. Do not scale from this drawing. Use only figured dimensions. The Contractor shall verify all dimensions on site, and report any discrepancies to the Architect before commencing work.

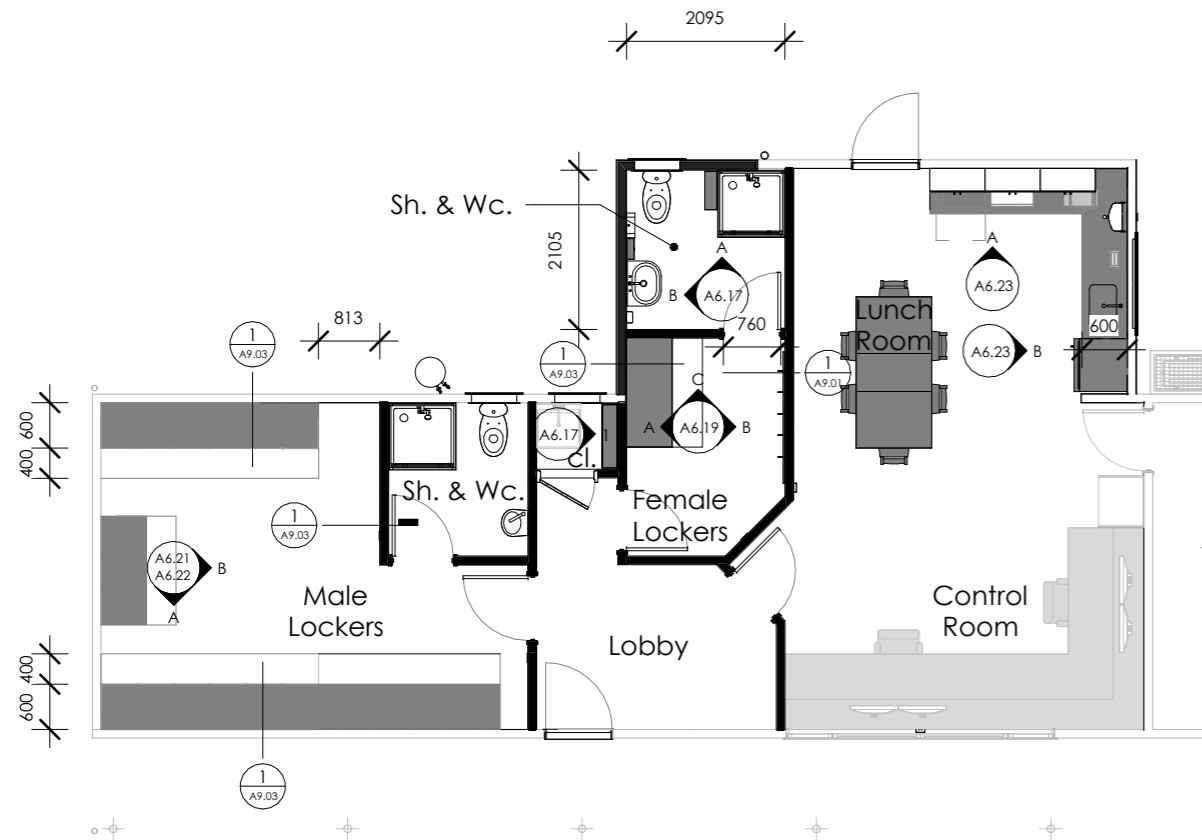

Joinery Location Plan - Boilers 4,5&6

1 : 100



Joinery Location Plan - Boilers 1&2

1 : 100



Copyright:
The copyright of this drawings remains the property of DLA Architects Limited and may only be used or re-used with DLA's prior written consent.

Project:
Clandeboyne Bio Mass Control Room & Amenities

Client:
Fonterra Clandeboyne

Drawing Title:
Joinery Location Plan
CAD File:

REV.	DATE	REVISION DETAILS
1	28/08/24	Tender Issue
0	27/05/24	First Issue

Scale: 1 : 100 @ A3	Date: 29/08/24	Drawn: MX
Job No: C919	Designed: MA	Checked: CG
Drawing No: A6.01	Revision No: 1	

General Notes:

1. This drawing shall be read in conjunction with all other drawings & specifications.
2. All work shall be strictly in accordance with the New Zealand Building Code, Local Territorial Authority Requirements, OSH Requirements & Regulations, and any other Statutory Requirements that may be applicable to this project.
3. All work shall be of best trade practice.
4. Do not scale from this drawing. Use only figured dimensions. The Contractor shall verify all dimensions on site, and report any discrepancies to the Architect before commencing work.

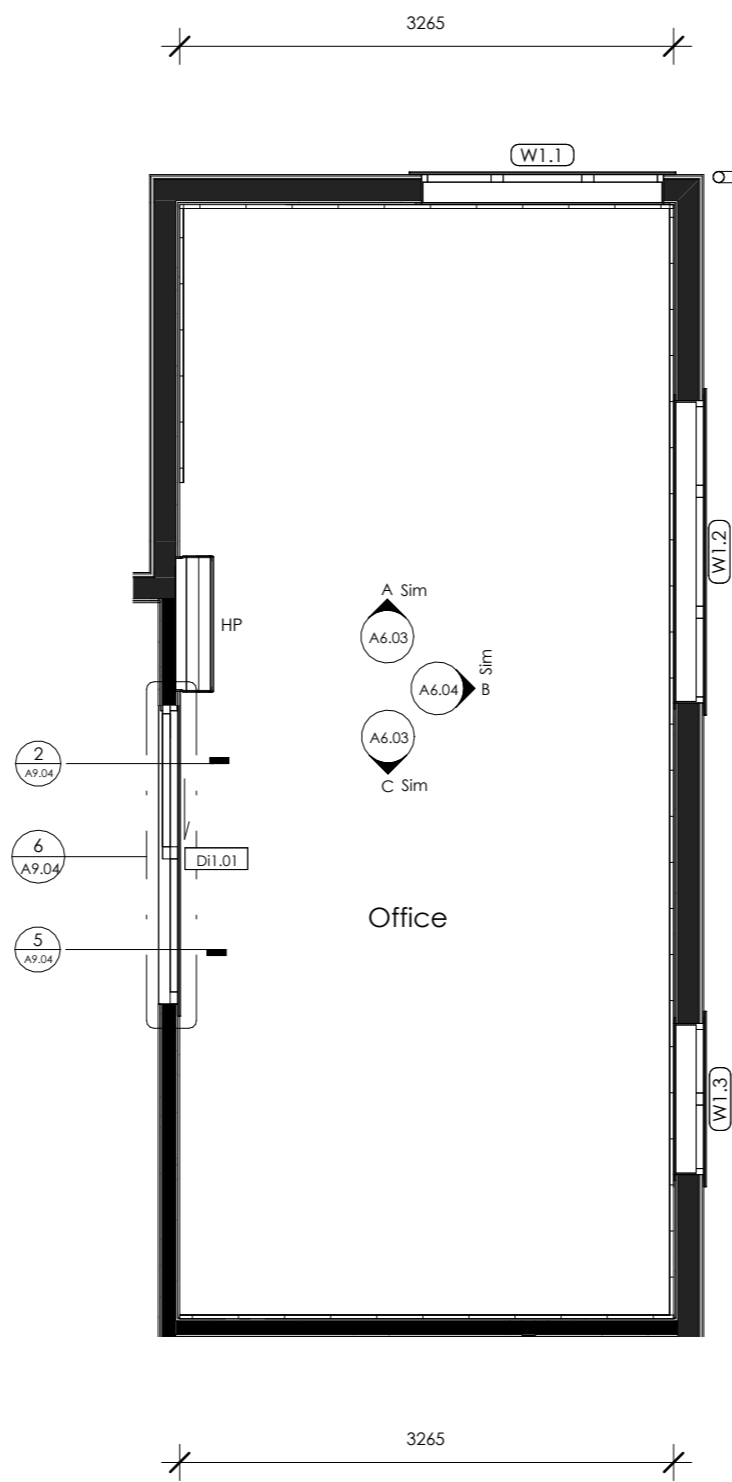

Boilers 1 & 2 Control Room Enlarged Plan - Office

1 : 50



Copyright:
The copyright of this drawings remains the property of DLA Architects Limited and may only be used or re-used with DLA's prior written consent.

Project:
Clandeboye Bio Mass Control Room & Amenities

Client:
Fonterra Clandeboye

Drawing Title:
Boilers 1&2 Control Room Enlarged Plan - Office
CAD File:

REV.	DATE	REVISION DETAILS
1	28/08/24	Tender Issue
0	27/05/24	First Issue

Scale: 1 : 50 @ A3	Date: 29/08/24	Drawn: MX
Job No: C919	Designed: MA	Checked: CG
Drawing No: A6.02	Revision No: 1	

General Notes:

1. This drawing shall be read in conjunction with all other drawings & specifications.
2. All work shall be strictly in accordance with the New Zealand Building Code, Local Territorial Authority Requirements, OSH Requirements & Regulations, and any other Statutory Requirements that may be applicable to this project.
3. All work shall be of best trade practice.
4. Do not scale from this drawing. Use only figured dimensions. The Contractor shall verify all dimensions on site, and report any discrepancies to the Architect before commencing work.

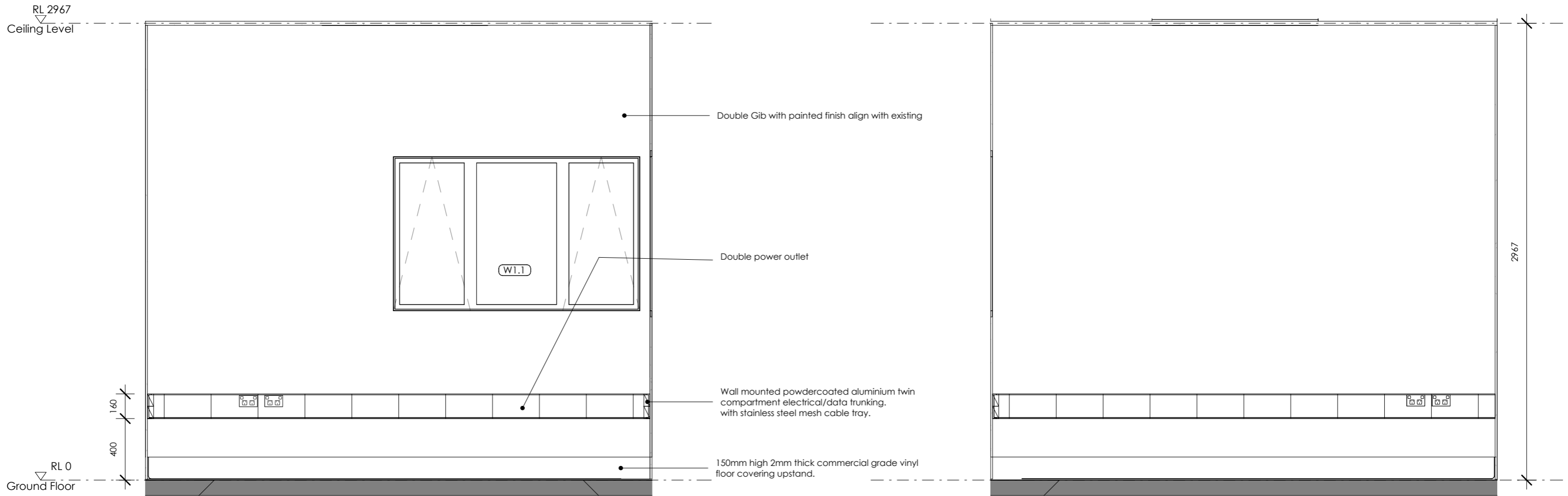

A Office Interior elevation A
A6.01 1 : 25 @ A3

C Office Interior elevation C
A6.01 1 : 25 @ A3



Copyright:
The copyright of this drawings remains the property of DLA Architects Limited and may only be used or re-used with DLA's prior written consent.

Project:
Clandeboyne Bio Mass Control Room & Amenities

Client:
Fonterra Clandeboyne

Drawing Title:
Boilers 1 & 2 Control Room - Office Elevation 1
CAD File:

REV.	DATE	REVISION DETAILS
1	28/08/24	Tender Issue
0	27/05/24	First Issue

Scale: 1 : 25 @ A3	Date: 29/08/24	Drawn: MX
Job No: C919	Designed: MA	Checked: CG
Drawing No: A6.03	Revision No: 1	

General Notes:

1. This drawing shall be read in conjunction with all other drawings & specifications.
2. All work shall be strictly in accordance with the New Zealand Building Code, Local Territorial Authority Requirements, OSH Requirements & Regulations, and any other Statutory Requirements that may be applicable to this project.
3. All work shall be of best trade practice.
4. Do not scale from this drawing. Use only figured dimensions. The Contractor shall verify all dimensions on site, and report any discrepancies to the Architect before commencing work.

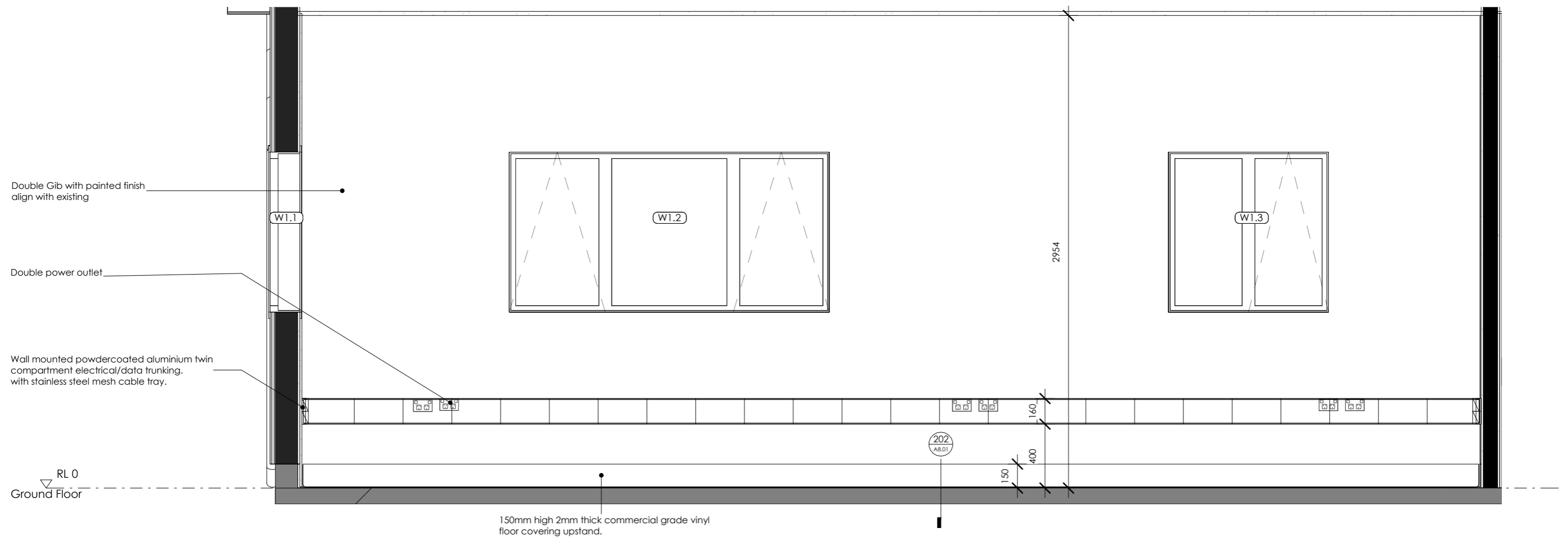

B Office Interior elevation B
A6.01 1 : 25 @ A3



Copyright:
The copyright of this drawings remains the property of DLA Architects Limited and may only be used or re-used with DLA's prior written consent.

Project:
Clandeboye Bio Mass Control Room & Amenities

Client:
Fonterra Clandeboye

Drawing Title:
Boilers 1 & 2 Control Room - Office Elevation 2
CAD File:

REV.	DATE	REVISION DETAILS
1	28/08/24	Tender Issue
0	27/05/24	First Issue

Scale: 1 : 25 @ A3	Date: 29/08/24	Drawn: MX
Job No: C919	Designed: MA	Checked: CG
Drawing No: A6.04	Revision No: 1	

General Notes:

1. This drawing shall be read in conjunction with all other drawings & specifications.
2. All work shall be strictly in accordance with the New Zealand Building Code, Local Territorial Authority Requirements, OSH Requirements & Regulations, and any other Statutory Requirements that may be applicable to this project.
3. All work shall be of best trade practice.
4. Do not scale from this drawing. Use only figured dimensions. The Contractor shall verify all dimensions on site, and report any discrepancies to the Architect before commencing work.

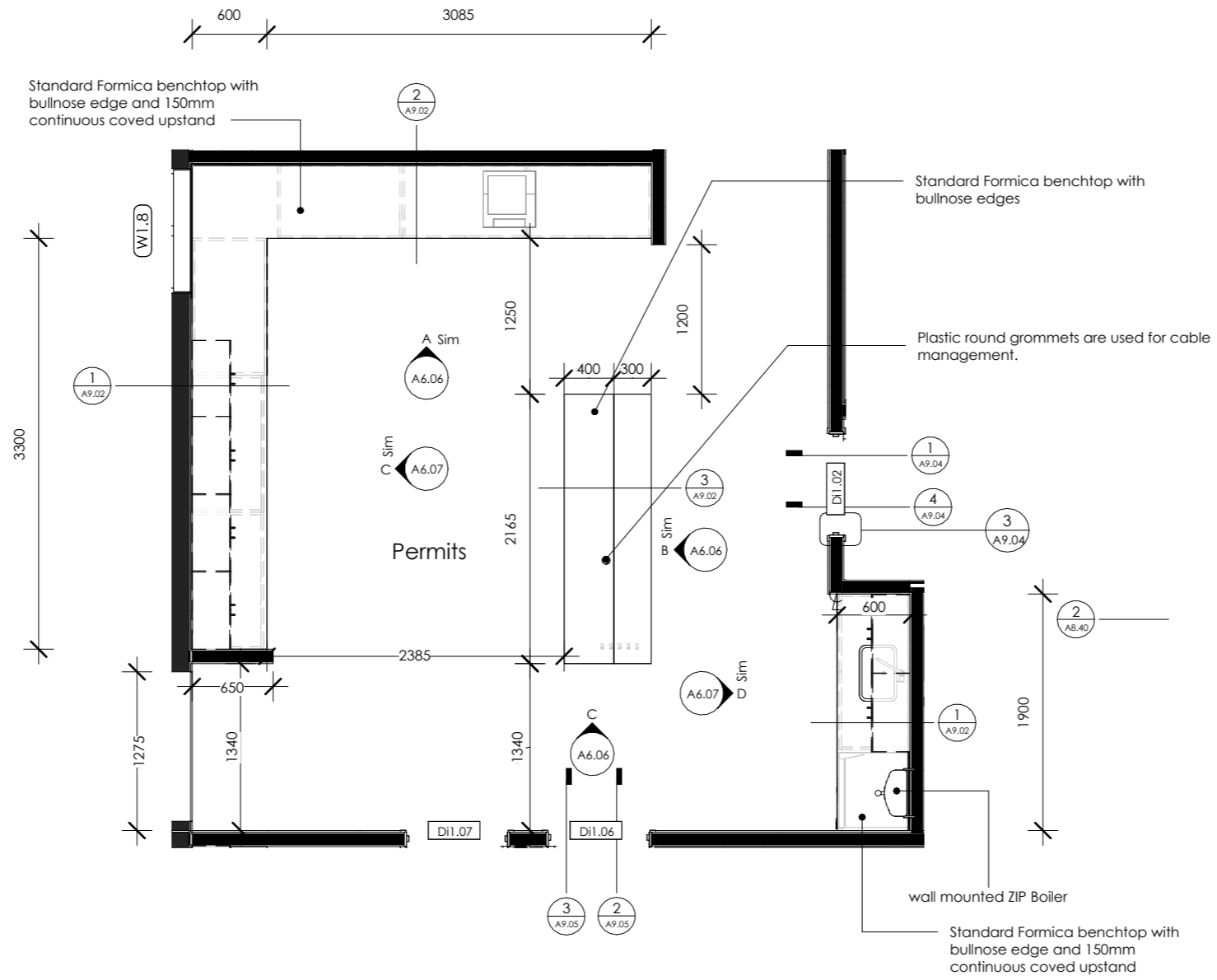

Boilers 1&2 Control Room Enlarged Plan - Permits

1 : 50

REV.	DATE	REVISION DETAILS
1	28/08/24	Tender Issue
0	27/05/24	First Issue

Scale: 1 : 50 @ A3	Date: 29/08/24	Drawn: MX
Job No: C919	Designed: MA	Checked: CG
Drawing No: A6.05	Revision No: 1	

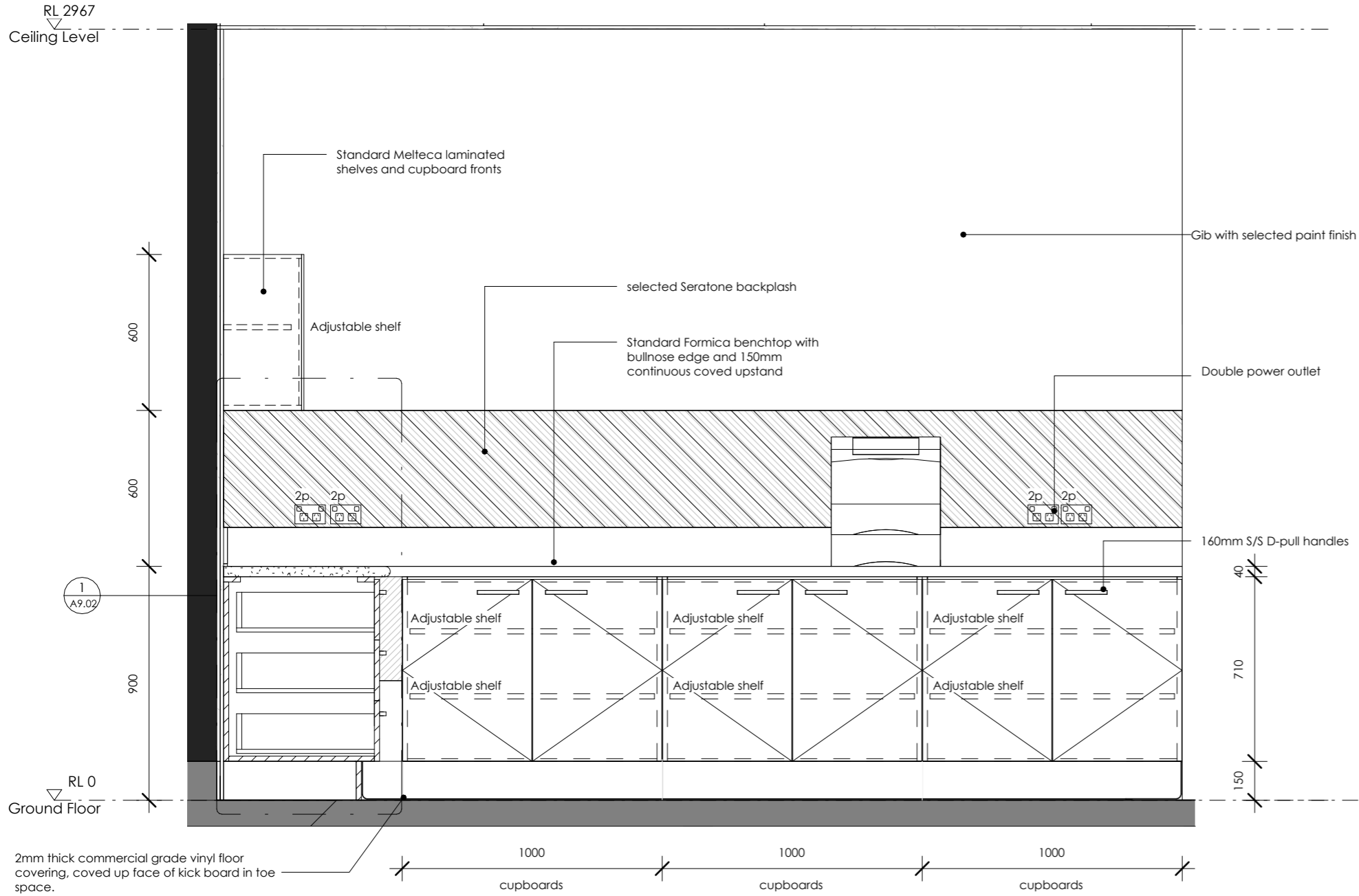

A interior elevation permits A
A6.01 1 : 20 @ A3

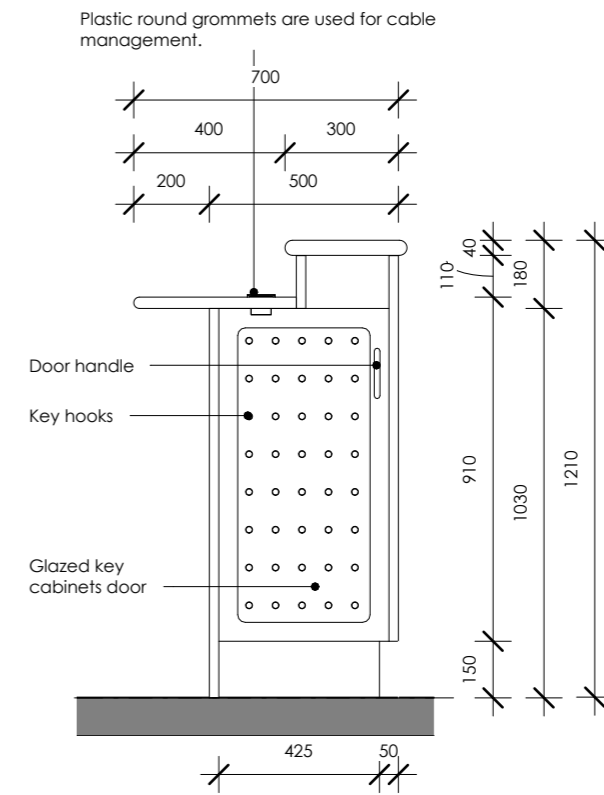

C Permits key cabinets interior elevation
A6.01 1 : 20 @ A3

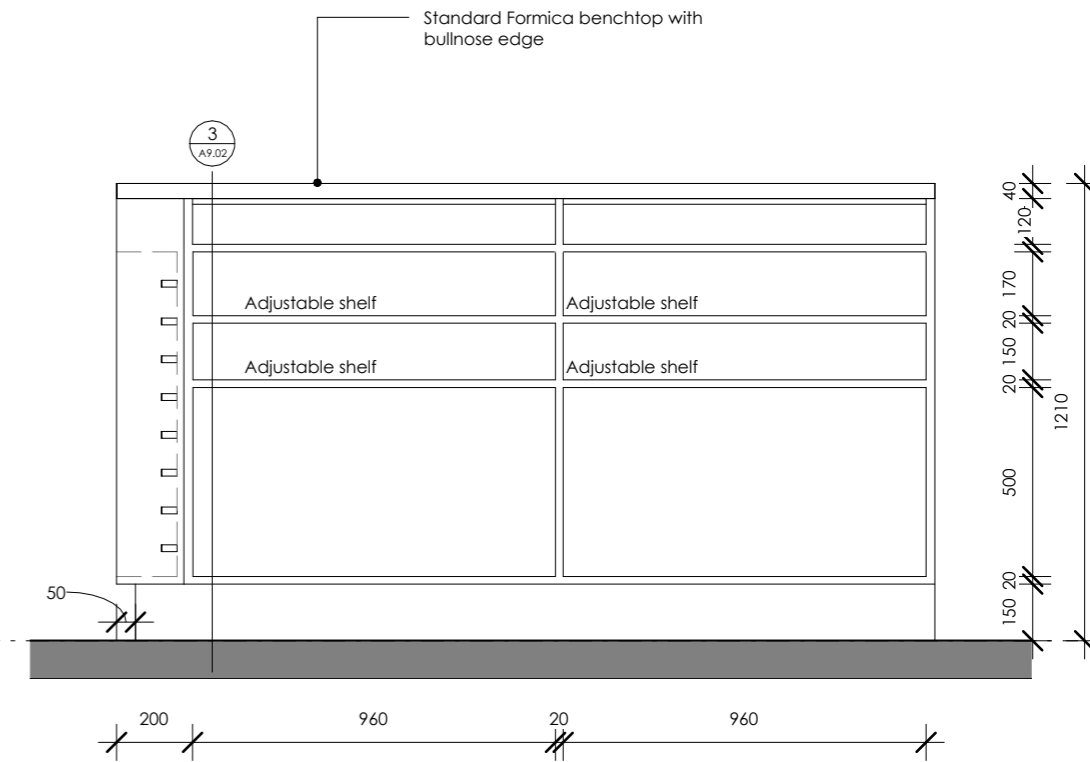

B interior elevation permits sign-in table
A6.01 1 : 20 @ A3

- General Notes:**
1. This drawing shall be read in conjunction with all other drawings & specifications.
 2. All work shall be strictly in accordance with the New Zealand Building Code, Local Territorial Authority Requirements, OSH Requirements & Regulations, and any other Statutory Requirements that may be applicable to this project.
 3. All work shall be of best trade practice.
 4. Do not scale from this drawing. Use only figured dimensions. The Contractor shall verify all dimensions on site, and report any discrepancies to the Architect before commencing work.

REV.	DATE	REVISION DETAILS
1	28/08/24	Tender Issue
0	27/05/24	First Issue

Scale: 1 : 20 @ A3	Date: 29/08/24	Drawn: MX
Job No: C919	Designed: MA	Checked: CG
Drawing No: A6.06	Revision No: 1	

General Notes:

1. This drawing shall be read in conjunction with all other drawings & specifications.
2. All work shall be strictly in accordance with the New Zealand Building Code, Local Territorial Authority Requirements, OSH Requirements & Regulations, and any other Statutory Requirements that may be applicable to this project.
3. All work shall be of best trade practice.
4. Do not scale from this drawing. Use only figured dimensions. The Contractor shall verify all dimensions on site, and report any discrepancies to the Architect before commencing work.

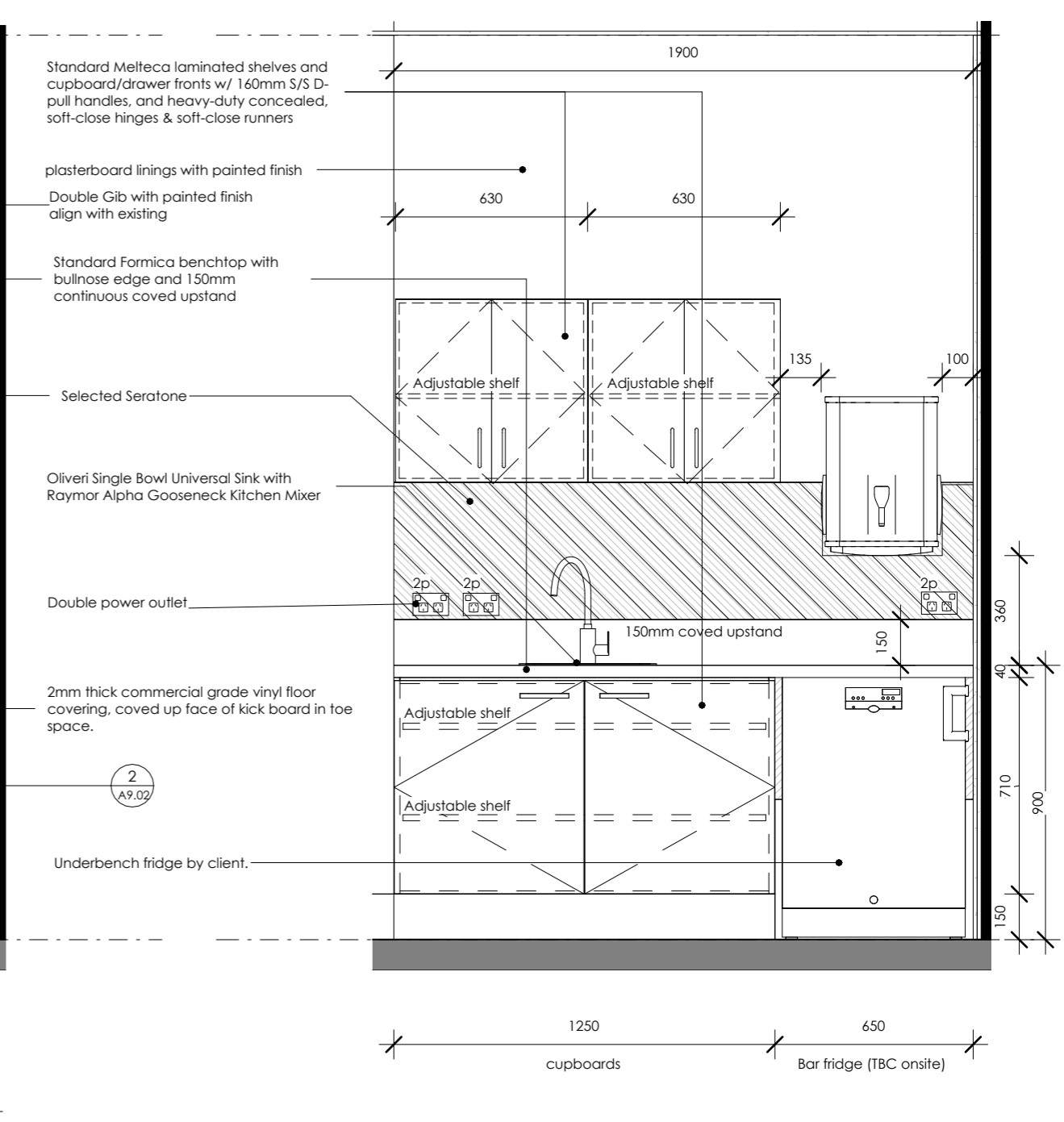
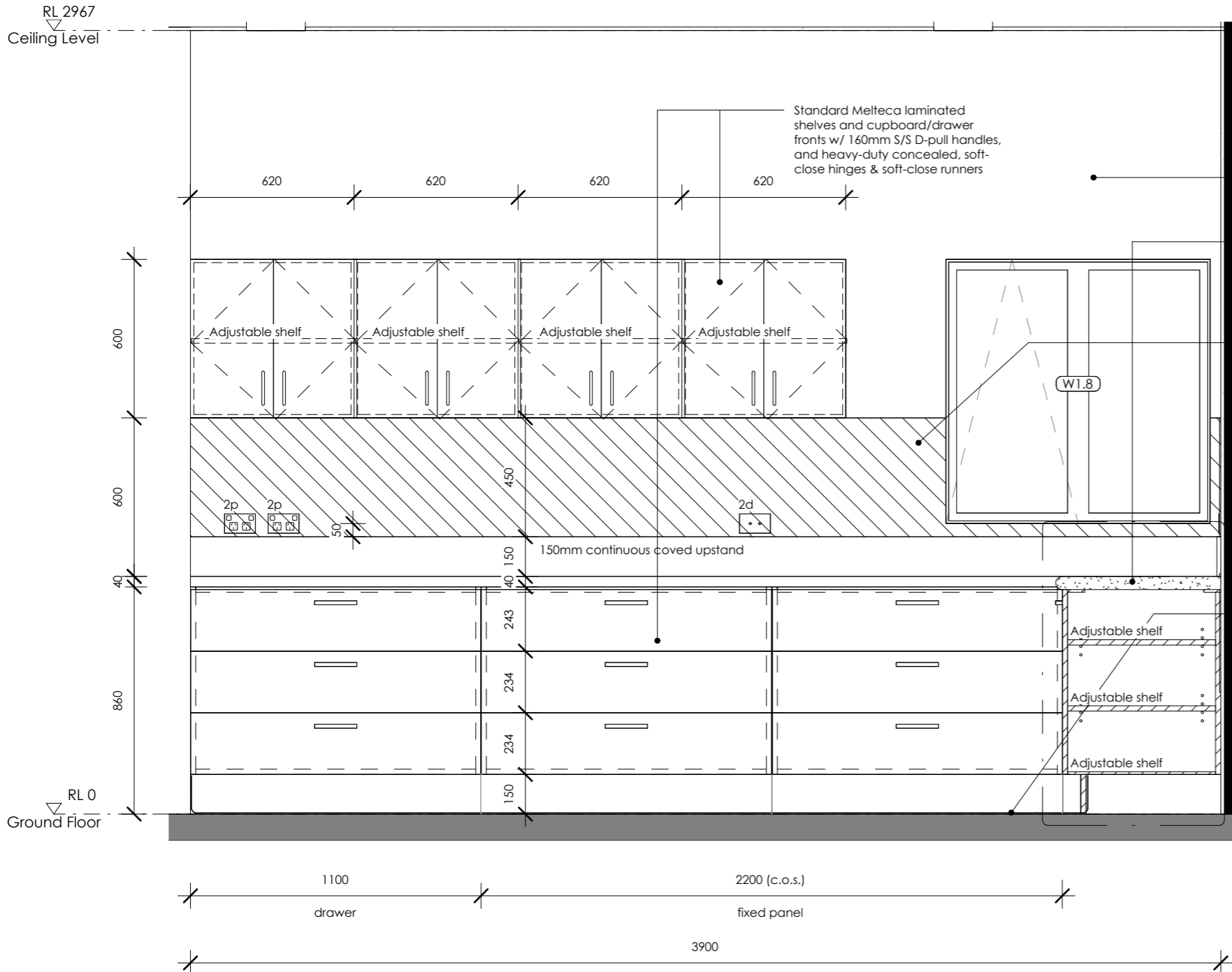

C interior elevation permits B
A6.01 1 : 20 @ A3

D interior elevation permits D
A6.01 1 : 20 @ A3



Copyright:
The copyright of this drawings remains the property of DLA Architects Limited and may only be used or re-used with DLA's prior written consent.

Project:
Clandeboyce Bio Mass Control Room & Amenities

Client:
Fonterra Clandeboyce

Drawing Title:
Boilers 1 & 2 Control Room - Permits Elevation 2
CAD File:

REV.	DATE	REVISION DETAILS
1	28/08/24	Tender Issue
0	27/05/24	First Issue

Scale: 1 : 20 @ A3	Date: 29/08/24	Drawn: MX
Job No: C919	Designed: MA	Checked: CG
Drawing No: A6.07	Revision No: 1	

- General Notes:**
1. This drawing shall be read in conjunction with all other drawings & specifications.
 2. All work shall be strictly in accordance with the New Zealand Building Code, Local Territorial Authority Requirements, OSH Requirements & Regulations, and any other Statutory Requirements that may be applicable to this project.
 3. All work shall be of best trade practice.
 4. Do not scale from this drawing. Use only figured dimensions. The Contractor shall verify all dimensions on site, and report any discrepancies to the Architect before commencing work.

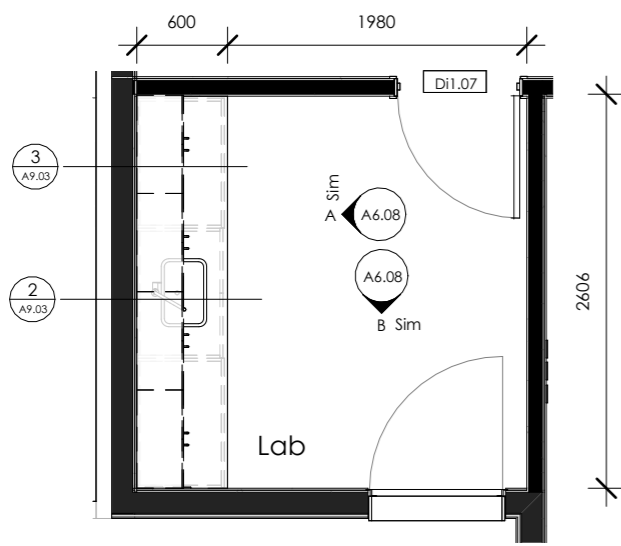

Boilers 1 & 2 Control Room Enlarged Plan - Lab
1 : 50

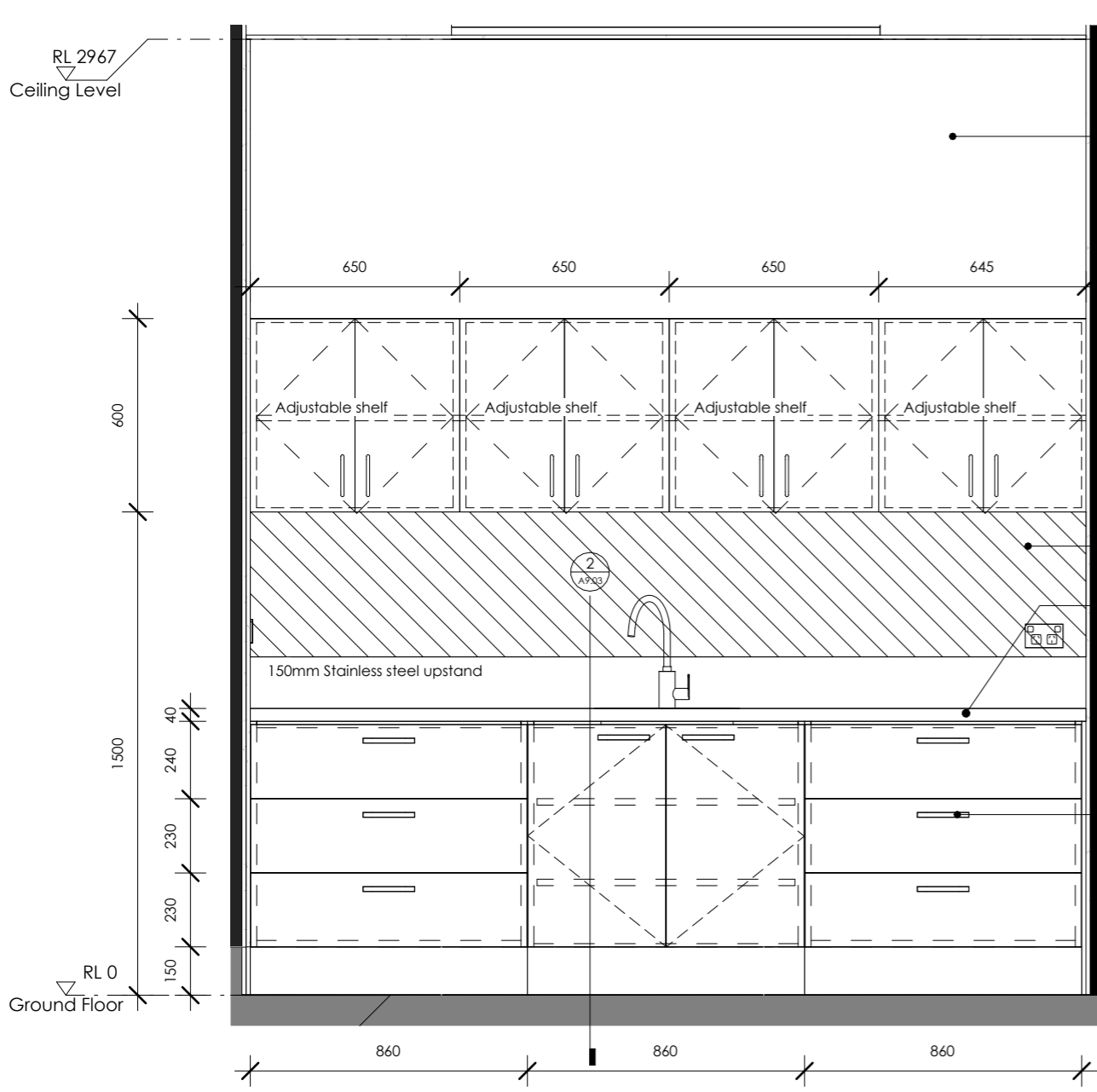

A interior elevation lab A
A6.01 1 : 20 @ A3

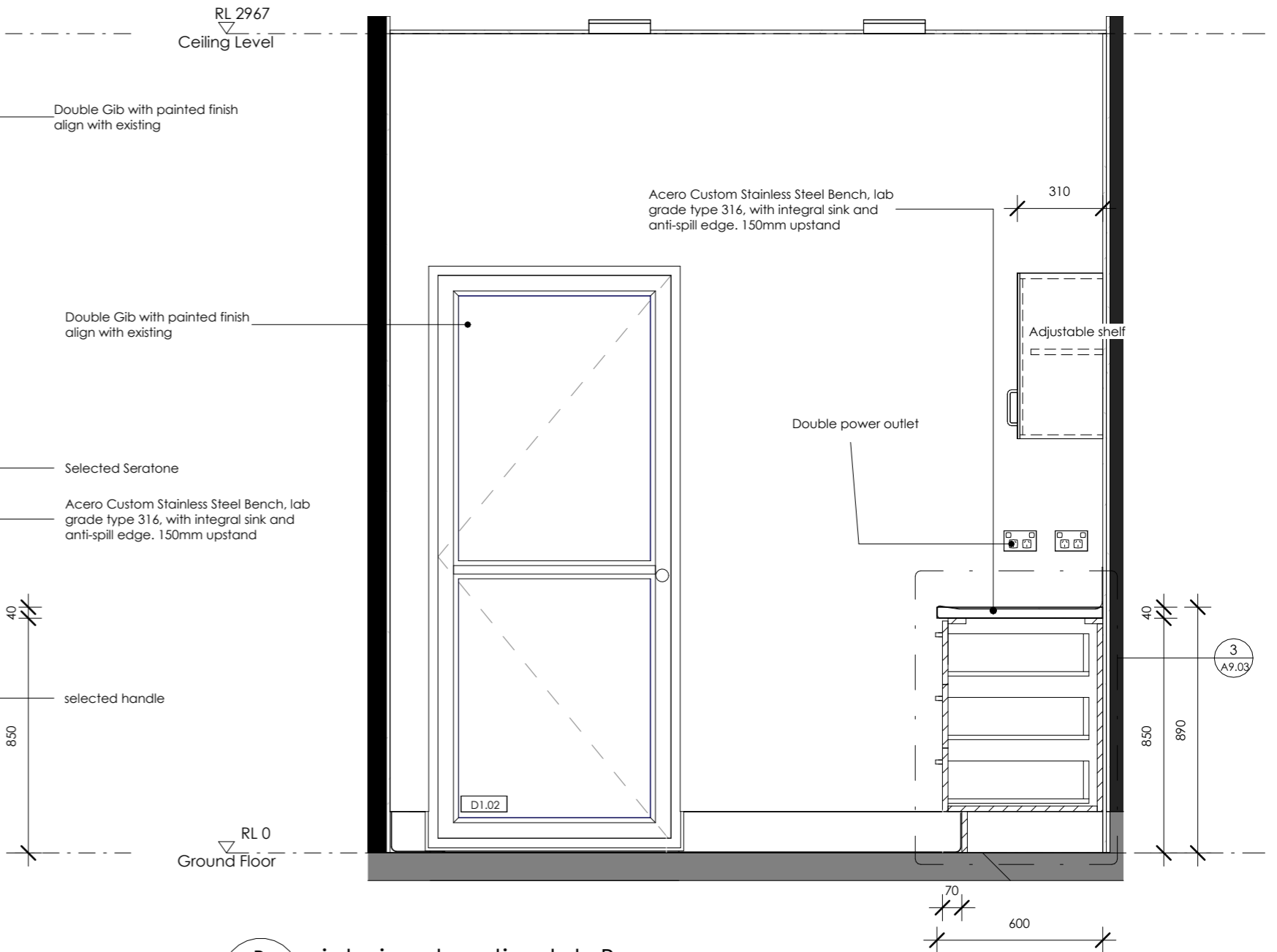

B interior elevation lab B
A6.01 1 : 20 @ A3



Copyright:
The copyright of this drawings remains the property of DLA Architects Limited and may only be used or re-used with DLA's prior written consent.

Project:
Clandeboyne Bio Mass Control Room & Amenities

Client:
Fonterra Clandeboyne

Drawing Title:
Boilers 1 & 2 Control Room - Lab Elevation
CAD File:

REV.	DATE	REVISION DETAILS
1	28/08/24	Tender Issue
0	27/05/24	First Issue

Scale: As indicated @ A3	Date: 29/08/24	Drawn: MX
Job No: C919	Designed: MA	Checked: CG
Drawing No: A6.08	Revision No: 1	

Keynote Legend Per Page

Key Value	Keynote Text
73.ACW	Accessible Toilet: Adesso Elevate Back to Wall Toilet Suite with Soft Close
73.SDU	Sanitary Disposal Unit.
73.SSD1	Soap Dispensers: Mediclinics Surface Push-Button Liquid Soap Dispenser - Matte Black Epoxy
73.TDP	Paper Towel dispensers.
73.TRH	Toilet Paper Holder.
73.WC	Toilet: Adesso Elevate Back to Wall Toilet Suite with Soft Close Seat Raised Button Set.
73.WHB	Accessible Wall Basin: Basin: Johnson Suisse Quado 450 Wall Hung Basin with Quado Shroud

General Notes:

1. This drawing shall be read in conjunction with all other drawings & specifications.
2. All work shall be strictly in accordance with the New Zealand Building Code, Local Territorial Authority Requirements, OSH Requirements & Regulations, and any other Statutory Requirements that may be applicable to this project.
3. All work shall be of best trade practice.
4. Do not scale from this drawing. Use only figured dimensions. The Contractor shall verify all dimensions on site, and report any discrepancies to the Architect before commencing work.

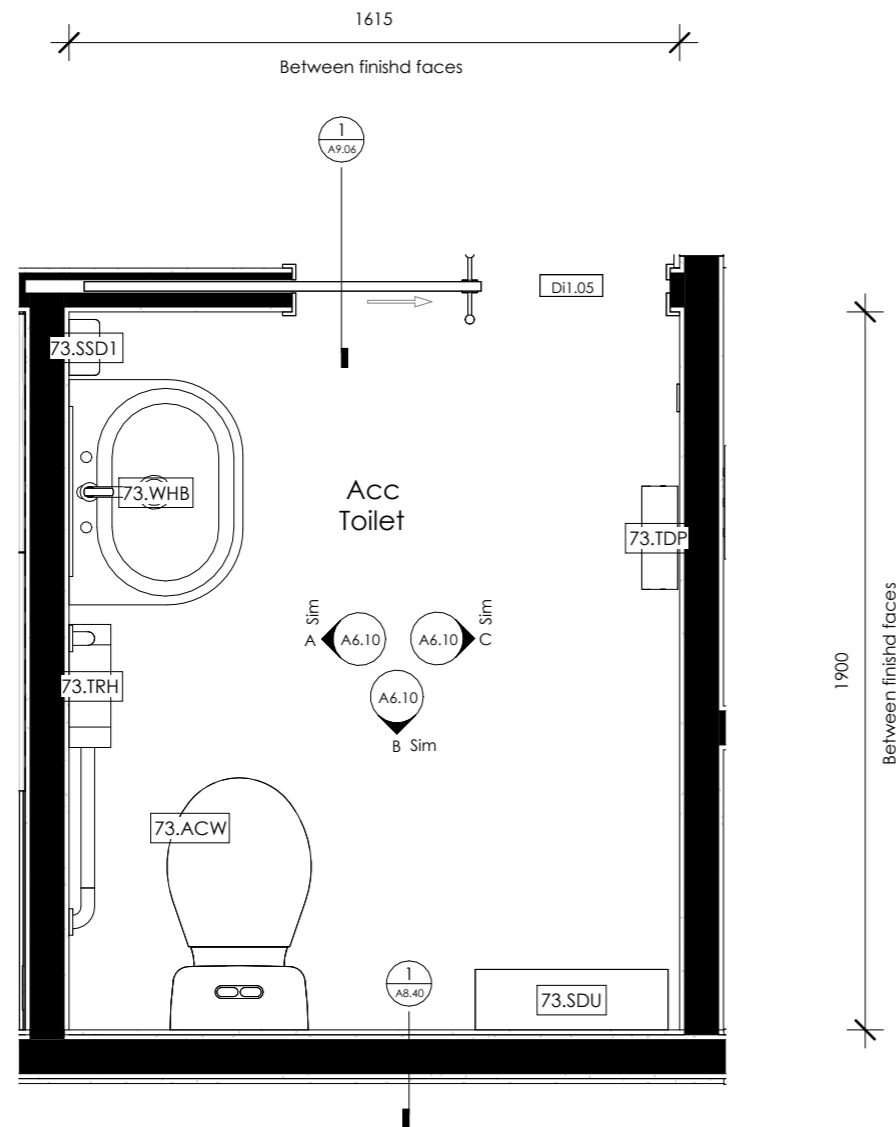

Boilers 1&2 Control Room Enlarged Plan - ACC Toilet

1 : 20

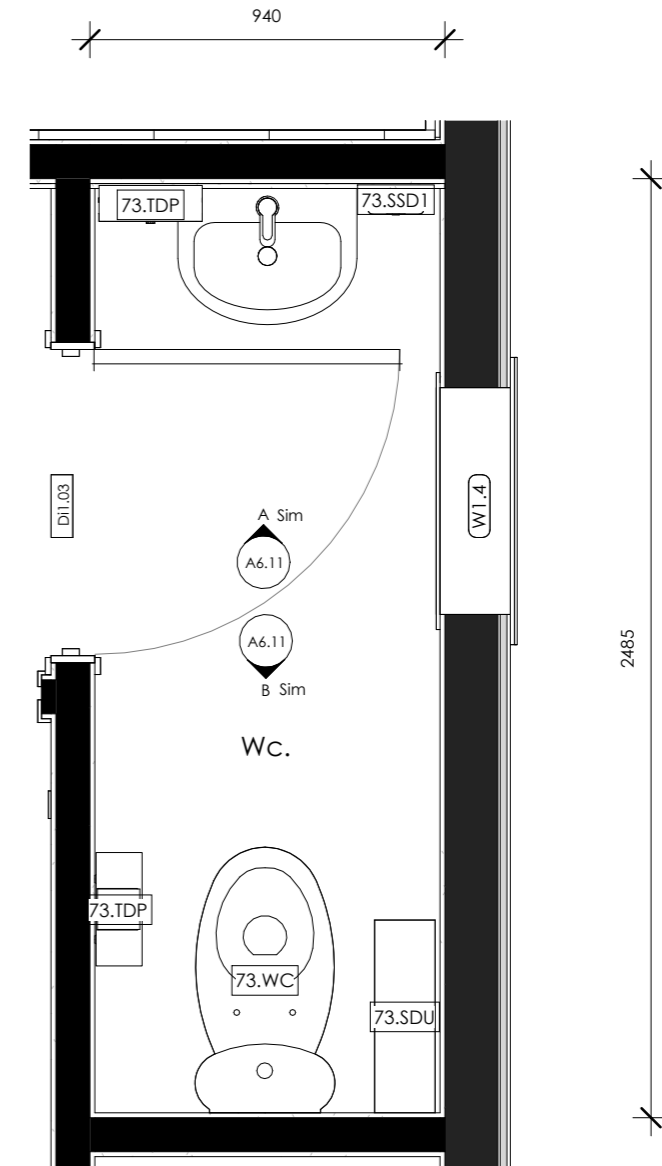

Boilers 1&2 Control Room Enlarged Plan - Wc.

1 : 20

Keynote Legend Per Page

Key Value	Keynote Text
73.ACW	Accessible Toilet: Adesso Elevate Back to Wall Toilet Suite with Soft Close
73.MRR	Mirror: Custom Mirrox Polished Edge Mirror No Fixings @ 450 x 850mm.
73.SDU	Sanitary Disposal Unit.
73.SSD1	Soap Dispensers: Mediclinics Surface Push-Button Liquid Soap Dispenser - Matte Black Epoxy
73.TDP	Paper Towel dispensers.
73.TRH	Toilet Paper Holder.
73.WHB	Accessible Wall Basin: Basin: Johnson Suisse Quado 450 Wall Hung Basin with Quado Shroud

General Notes:

1. This drawing shall be read in conjunction with all other drawings & specifications.
2. All work shall be strictly in accordance with the New Zealand Building Code, Local Territorial Authority Requirements, OSH Requirements & Regulations, and any other Statutory Requirements that may be applicable to this project.
3. All work shall be of best trade practice.
4. Do not scale from this drawing. Use only figured dimensions. The Contractor shall verify all dimensions on site, and report any discrepancies to the Architect before commencing work.

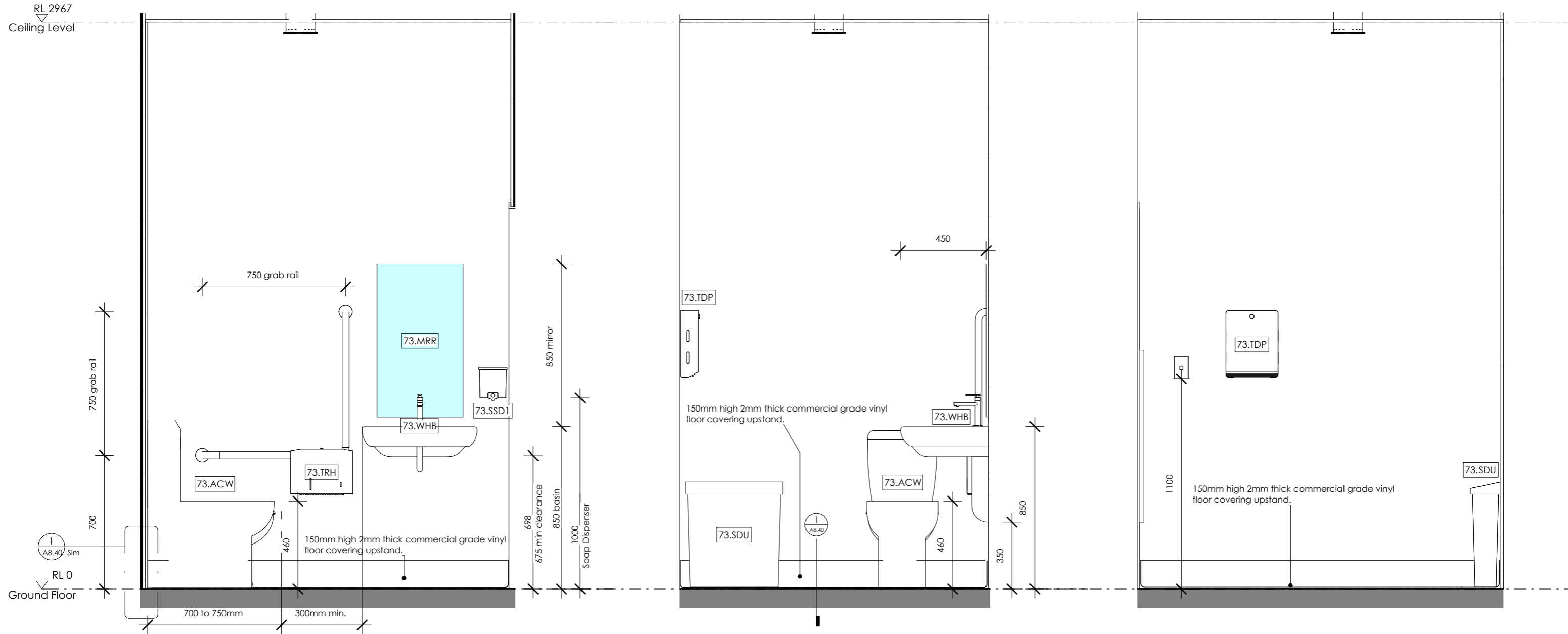

A interior elevation ACC Toilet A
A6.01 1 : 20 @ A3

B interior elevation ACC Toilet B
A6.01 1 : 20 @ A3

C interior elevation ACC Toilet C
A6.01 1 : 20 @ A3



Copyright:
The copyright of this drawings remains the property of DLA Architects Limited and may only be used or re-used with DLA's prior written consent.

Project:
Clandeboyne Bio Mass Control Room & Amenities

Client:
Fonterra Clandeboyne

Drawing Title:
Boilers 1 & 2 Control Room - Acc Toilet Elevation
CAD File:

REV.	DATE	REVISION DETAILS
1	28/08/24	Tender Issue
0	27/05/24	First Issue

Scale: 1 : 20 @ A3	Date: 29/08/24	Drawn: MX
Job No: C919	Designed: MA	Checked: CG
Drawing No: A6.10	Revision No: 1	

Keynote Legend Per Page

Key Value	Keynote Text
73.SDU	Sanitary Disposal Unit.
73.SSD1	Soap Dispensers: Mediclinics Surface Push-Button Liquid Soap Dispenser - Matte Black Epoxy
73.TDP	Paper Towel dispensers.
73.WC	Toilet: Adesso Elevate Back to Wall Toilet Suite with Soft Close Seat Raised Button Set.

General Notes:

1. This drawing shall be read in conjunction with all other drawings & specifications.
2. All work shall be strictly in accordance with the New Zealand Building Code, Local Territorial Authority Requirements, OSH Requirements & Regulations, and any other Statutory Requirements that may be applicable to this project.
3. All work shall be of best trade practice.
4. Do not scale from this drawing. Use only figured dimensions. The Contractor shall verify all dimensions on site, and report any discrepancies to the Architect before commencing work.

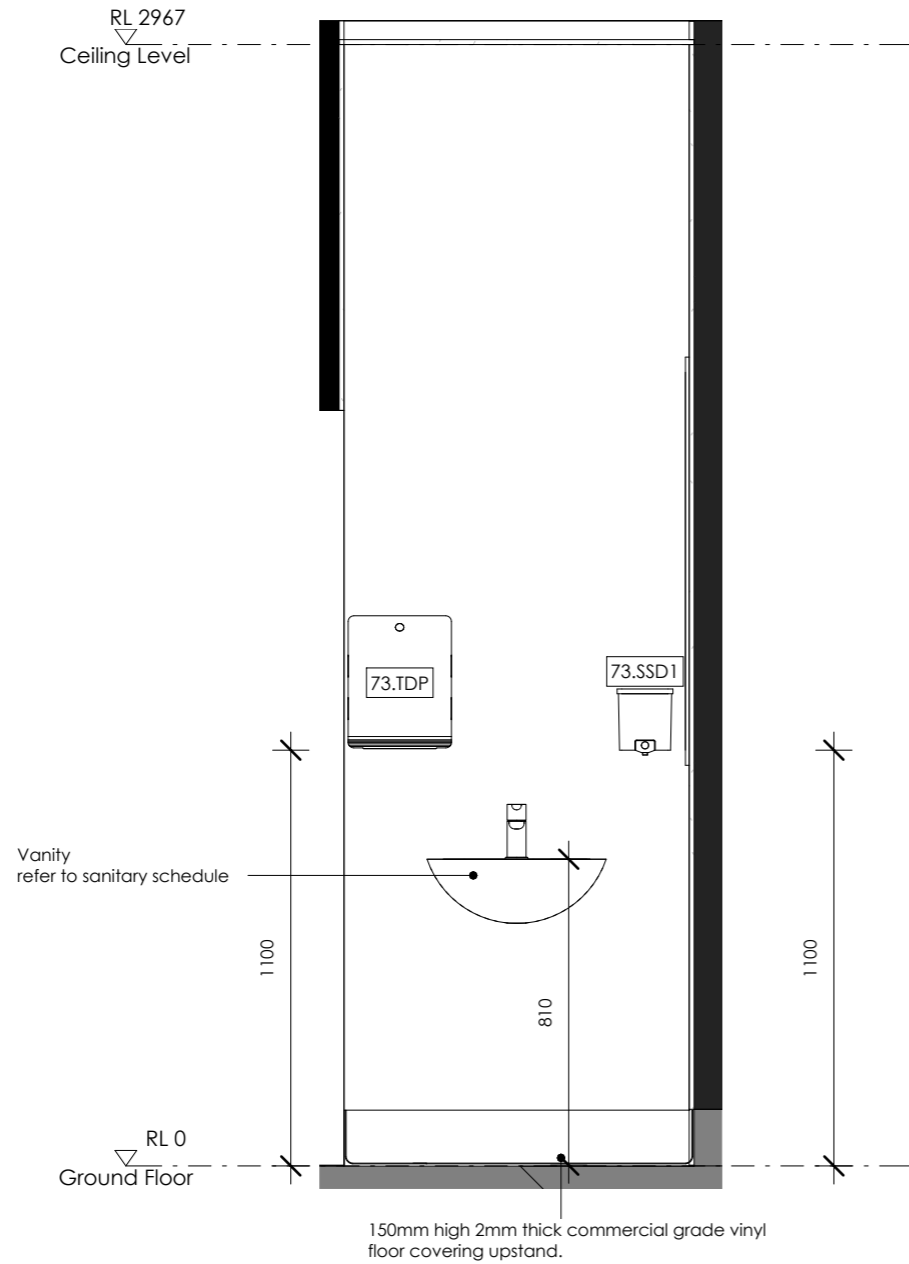

A interior elevation Wc. A
A6.01 1 : 20 @ A3

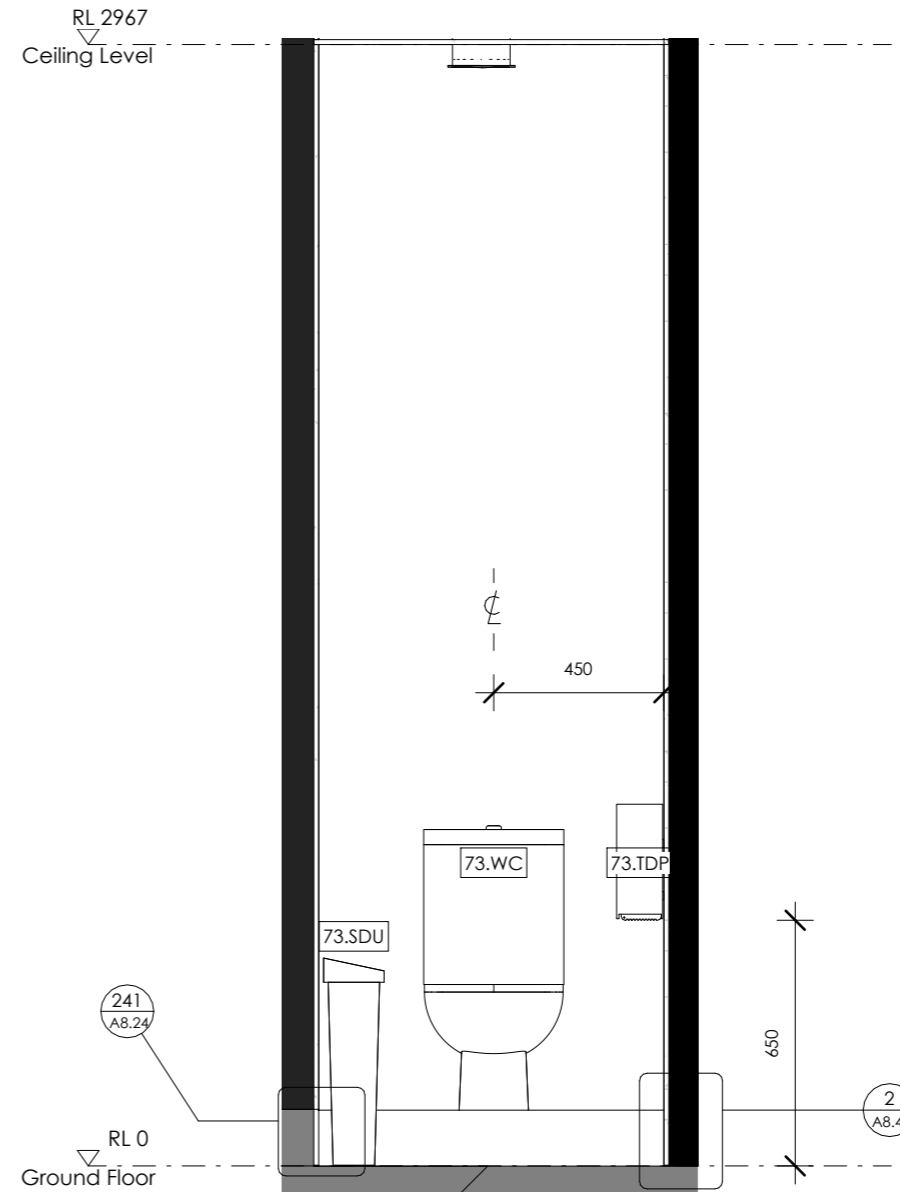

B interior elevation Wc. B
A6.01 1 : 20 @ A3

General Notes:

1. This drawing shall be read in conjunction with all other drawings & specifications.
2. All work shall be strictly in accordance with the New Zealand Building Code, Local Territorial Authority Requirements, OSH Requirements & Regulations, and any other Statutory Requirements that may be applicable to this project.
3. All work shall be of best trade practice.
4. Do not scale from this drawing. Use only figured dimensions. The Contractor shall verify all dimensions on site, and report any discrepancies to the Architect before commencing work.

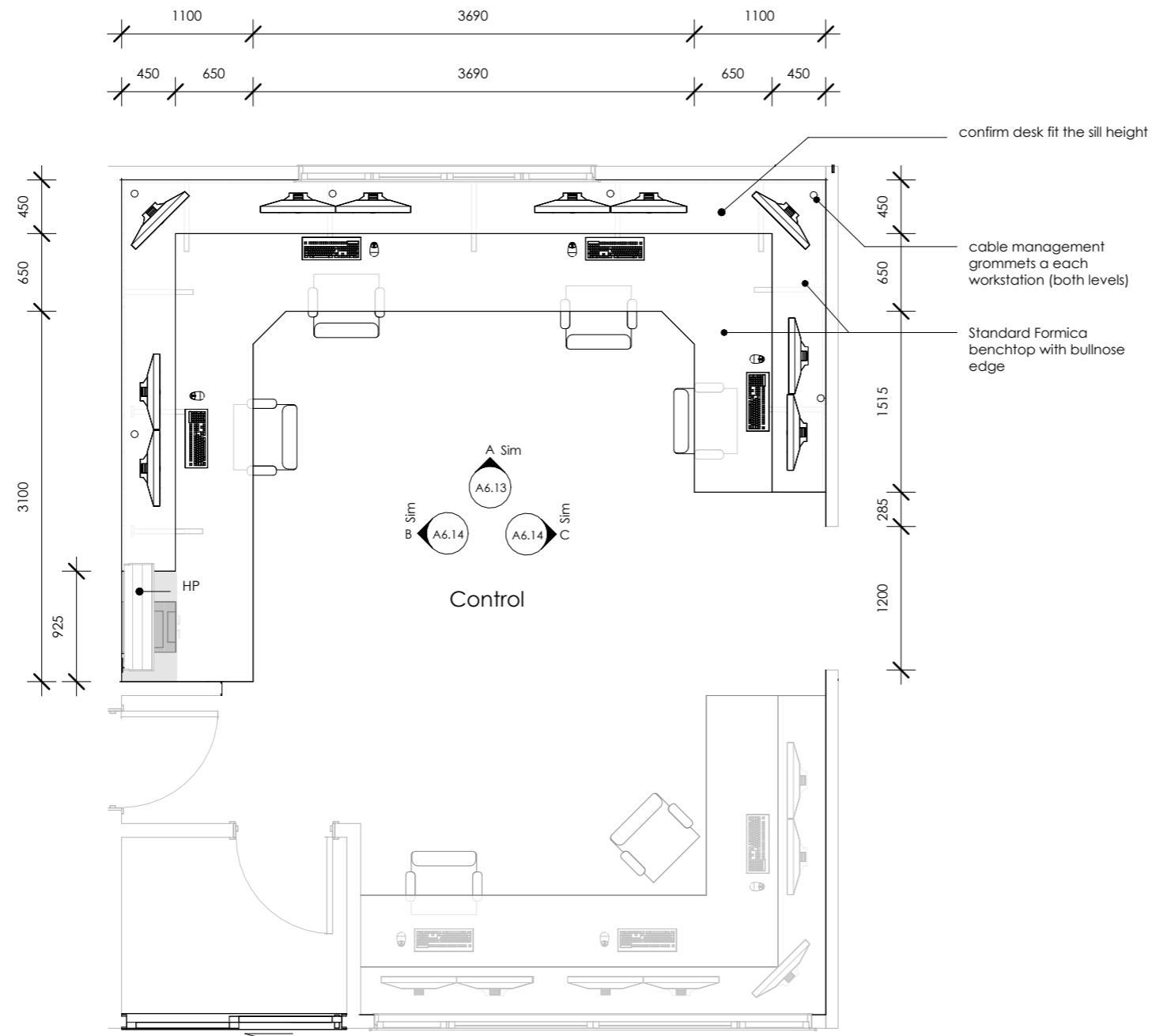

Boilers 1&2 Control Room Enlarged Plan - Control Room

1 : 50

REV.	DATE	REVISION DETAILS
1	28/08/24	Tender Issue
0	27/05/24	First Issue

Scale: 1 : 50 @ A3	Date: 29/08/24	Drawn: MX
Job No: C919	Designed: MA	Checked: CG
Drawing No: A6.12	Revision No: 1	

Keynote Legend Per Page

Key Value	Keynote Text
52.SSO	SOCKET: Switched socket outlets.

General Notes:

1. This drawing shall be read in conjunction with all other drawings & specifications.
2. All work shall be strictly in accordance with the New Zealand Building Code, Local Territorial Authority Requirements, OSH Requirements & Regulations, and any other Statutory Requirements that may be applicable to this project.
3. All work shall be of best trade practice.
4. Do not scale from this drawing. Use only figured dimensions. The Contractor shall verify all dimensions on site, and report any discrepancies to the Architect before commencing work.

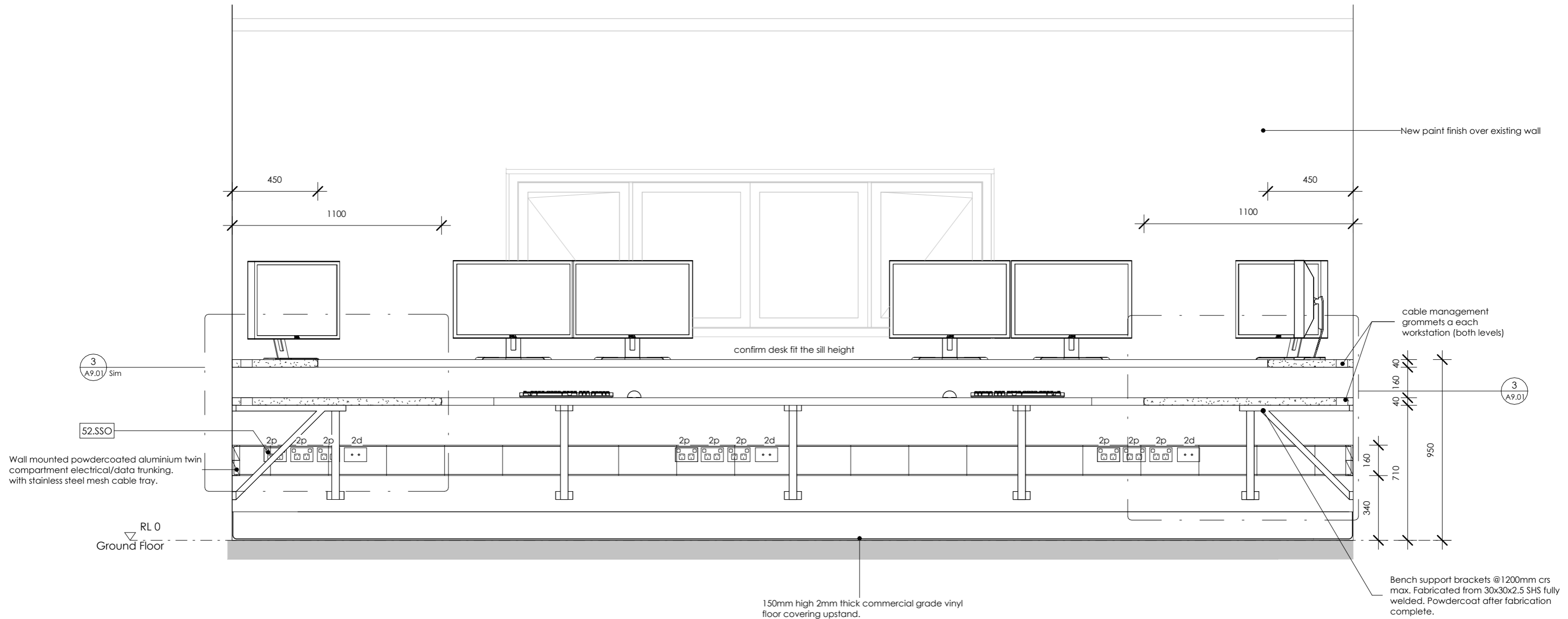

A interior elevation Control Room A
 A6.01 1 : 20 @ A3



Copyright:
 The copyright of this drawings remains the property of DLA Architects Limited and may only be used or re-used with DLA's prior written consent.

Project:
 Clandeboye Bio Mass Control Room & Amenities

Client:
 Fonterra Clandeboye

Drawing Title:
 Boilers 1 & 2 Control Room - Control room Elevation 1
 CAD File:

REV.	DATE	REVISION DETAILS
1	28/08/24	Tender Issue
0	27/05/24	First Issue

Scale: 1 : 20 @ A3	Date: 29/08/24	Drawn: MX
Job No: C919	Designed: MA	Checked: CG
Drawing No: A6.13	Revision No: 1	

General Notes:

1. This drawing shall be read in conjunction with all other drawings & specifications.
2. All work shall be strictly in accordance with the New Zealand Building Code, Local Territorial Authority Requirements, OSH Requirements & Regulations, and any other Statutory Requirements that may be applicable to this project.
3. All work shall be of best trade practice.
4. Do not scale from this drawing. Use only figured dimensions. The Contractor shall verify all dimensions on site, and report any discrepancies to the Architect before commencing work.

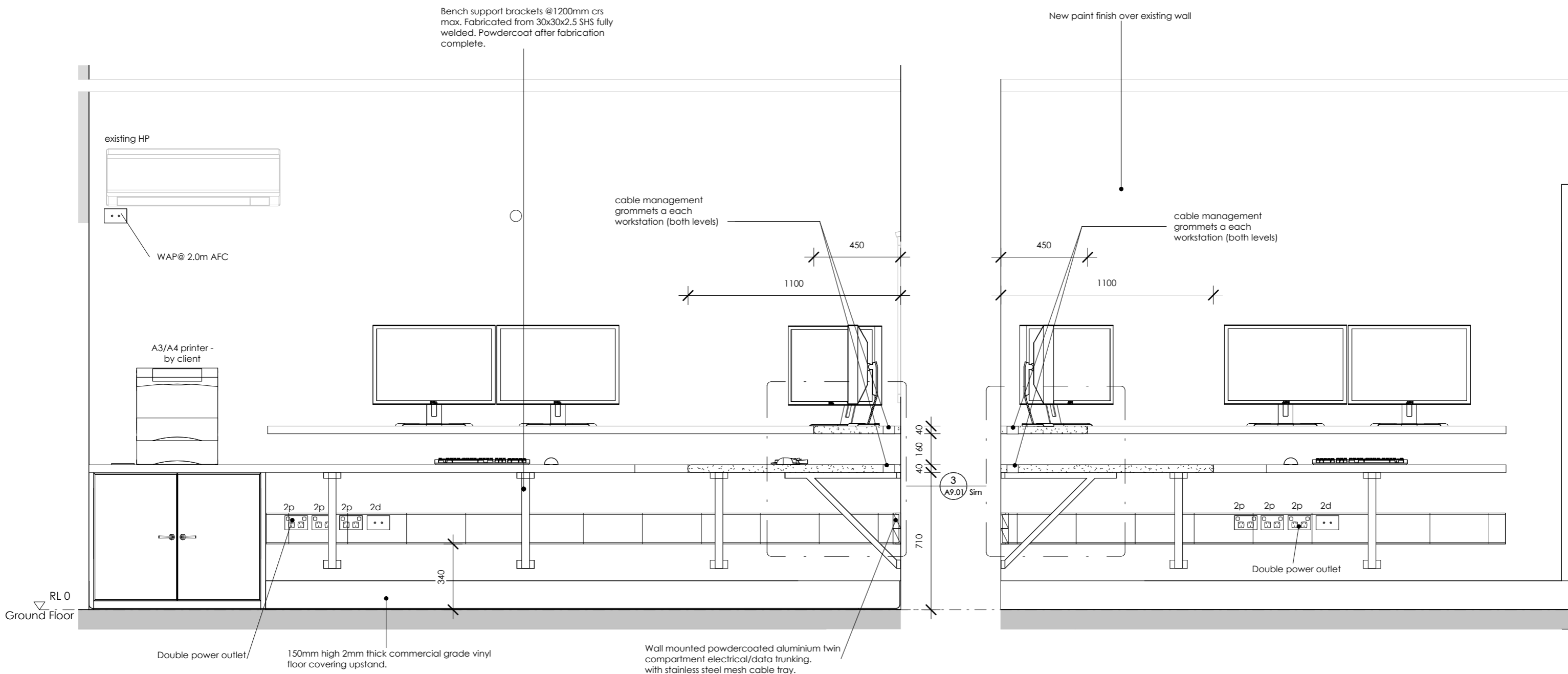

B interior elevation Control Room B
A6.01 1 : 20 @ A3

C interior elevation Control Room C
A6.01 1 : 20 @ A3



Copyright:
The copyright of this drawings remains the property of DLA Architects Limited and may only be used or re-used with DLA's prior written consent.

Project:
Clandeboye Bio Mass Control Room & Amenities

Client:
Fonterra Clandeboye

Drawing Title:
Boilers 1 & 2 Control Room - Control room Elevation 2
CAD File:

REV.	DATE	REVISION DETAILS
1	28/08/24	Tender Issue
0	27/05/24	First Issue

Scale: 1 : 20 @ A3	Date: 29/08/24	Drawn: MX
Job No: C919	Designed: MA	Checked: CG
Drawing No: A6.14	Revision No: 1	

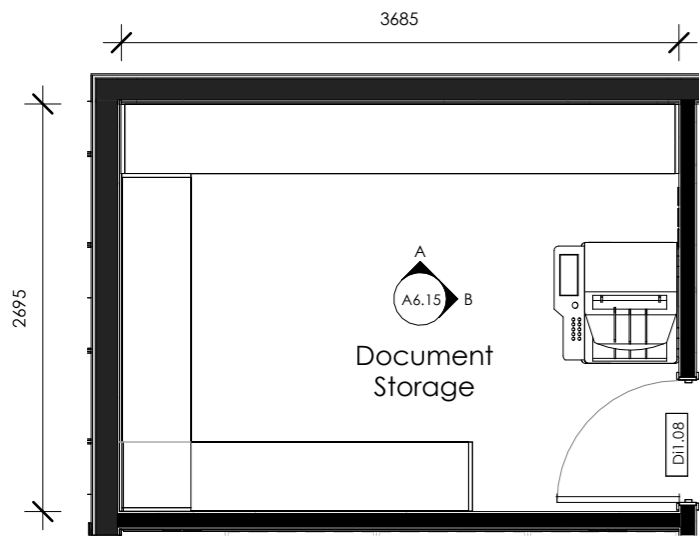

Boilers 1 & 2 Control Room Enlarged Plan - Document Storage

1 : 50

- General Notes:**
1. This drawing shall be read in conjunction with all other drawings & specifications.
 2. All work shall be strictly in accordance with the New Zealand Building Code, Local Territorial Authority Requirements, OSH Requirements & Regulations, and any other Statutory Requirements that may be applicable to this project.
 3. All work shall be of best trade practice.
 4. Do not scale from this drawing. Use only figured dimensions. The Contractor shall verify all dimensions on site, and report any discrepancies to the Architect before commencing work.

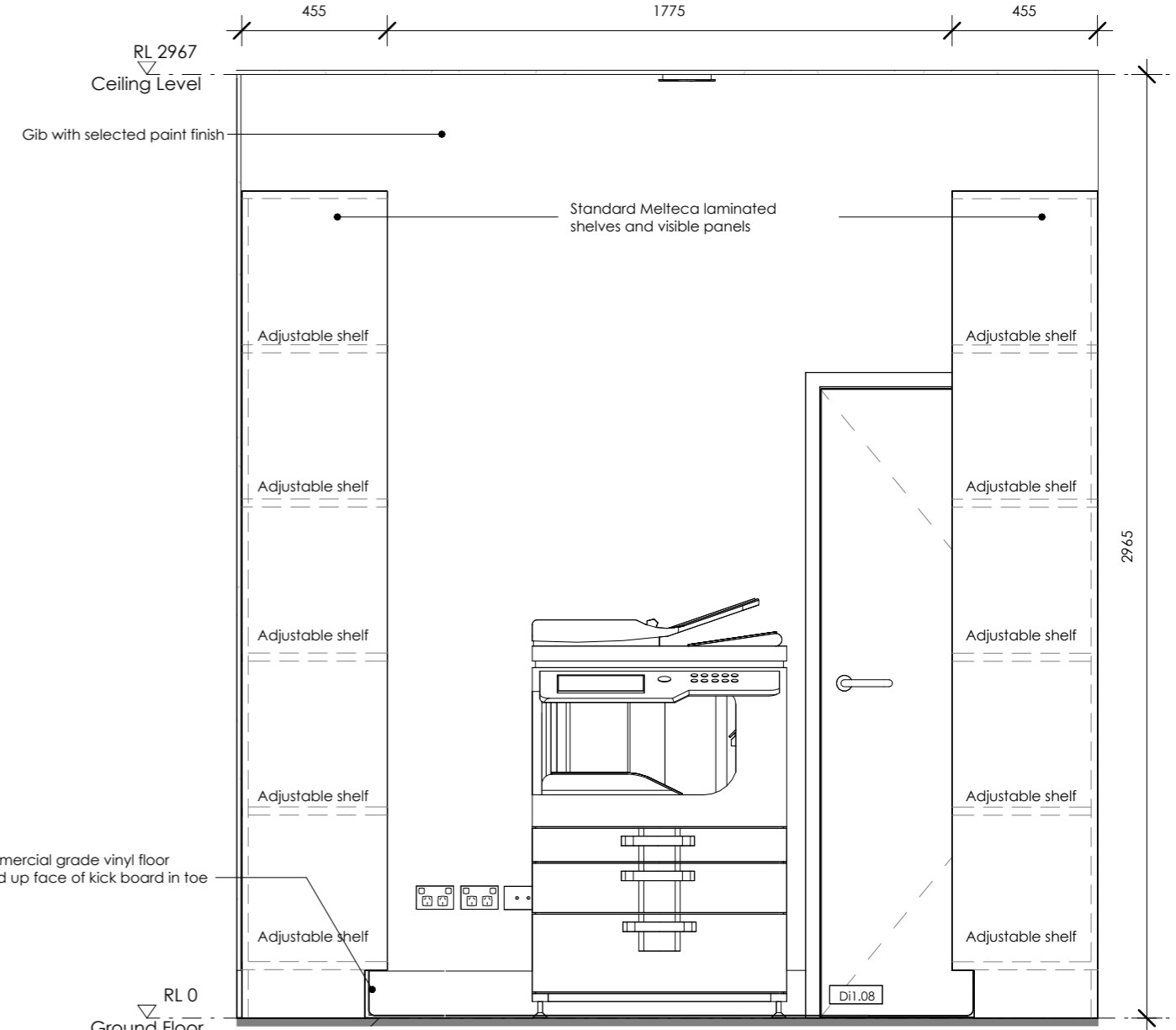
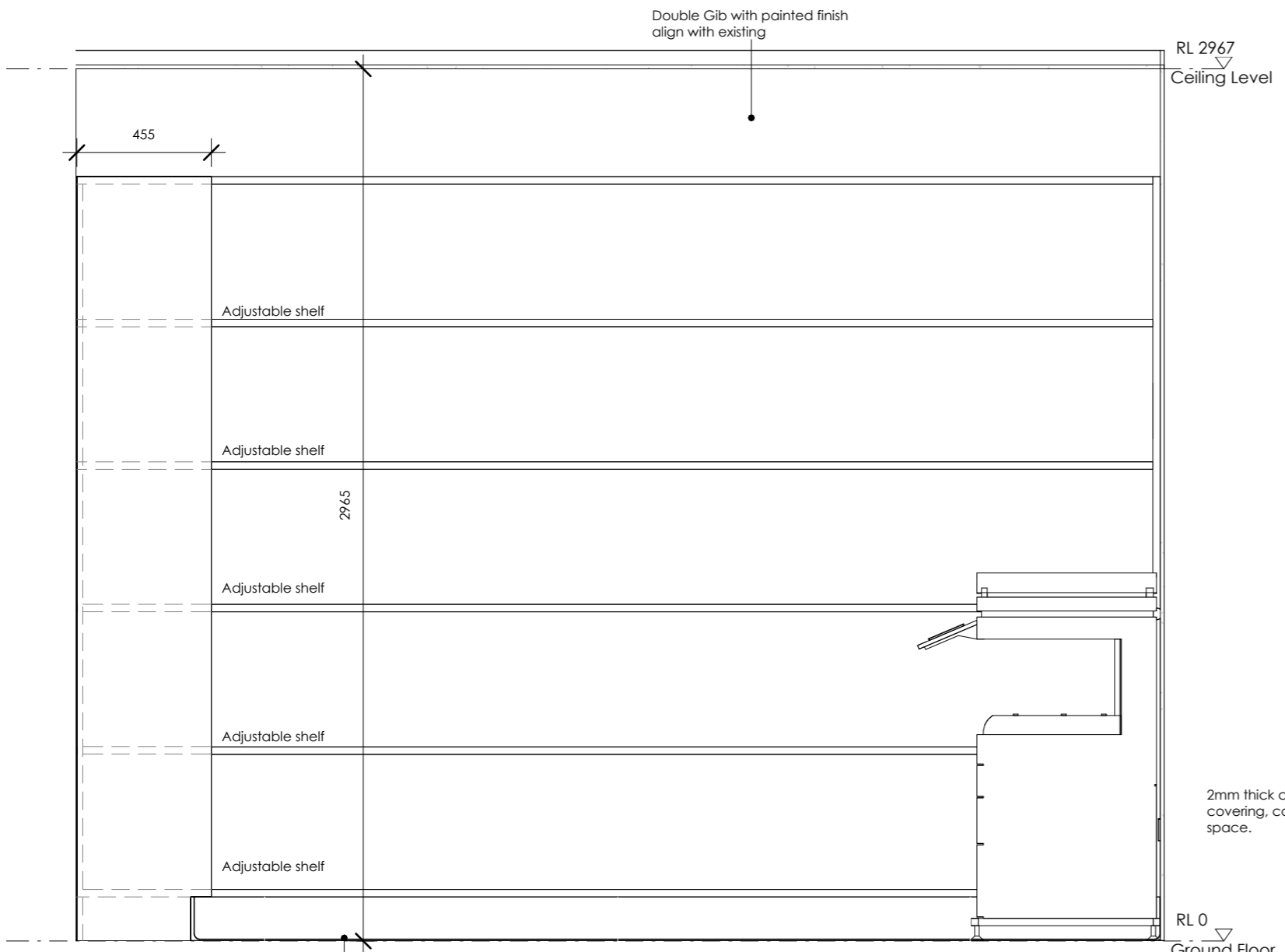

A interior elevation Document Storage A

A6.01 1 : 20 @ A3

B interior elevation Document Storage B

A6.01 1 : 20 @ A3



Copyright:
The copyright of this drawings remains the property of DLA Architects Limited and may only be used or re-used with DLA's prior written consent.

Project:
Clandeboye Bio Mass Control Room & Amenities

Client:
Fonterra Clandeboye

Drawing Title:
Boilers 1 & 2 Control Room - Document Storage Elevation
CAD File:

REV.	DATE	REVISION DETAILS
1	28/08/24	Tender Issue
0	27/05/24	First Issue

Scale: As indicated @ A3	Date: 29/08/24	Drawn: MX
Job No: C919	Designed: MA	Checked: CG
Drawing No: A6.15	Revision No: 1	

Keynote Legend Per Page	
Key Value	Keynote Text
64.VS3	VINYL SURFACING 03: 2mm thick Jacobsens Tarkett Primo Safe.T NON-SLIP commercial grade floor vinyl glued and fixed in accordance with the manufacturers specification, covered 150mm unless stated otherwise. Welded Joints. Refer to Colour Schedule.
73.SDU	Sanitary Disposal Unit.
73.SHR	Cubicle shower unit.
73.SSD1	Soap Dispensers: Mediclinics Surface Push-Button Liquid Soap Dispenser - Matte Black Epoxy
73.TDP	Paper Towel dispensers.
73.TRH	Toilet Paper Holder.
73.WC	Toilet: Adesso Elevate Back to Wall Toilet Suite with Soft Close Seat Raised Button Set.
73.WHB	Accessible Wall Basin: Basin: Johnson Suisse Quado 450 Wall Hung Basin with Quado Shroud

General Notes:

1. This drawing shall be read in conjunction with all other drawings & specifications.
2. All work shall be strictly in accordance with the New Zealand Building Code, Local Territorial Authority Requirements, OSH Requirements & Regulations, and any other Statutory Requirements that may be applicable to this project.
3. All work shall be of best trade practice.
4. Do not scale from this drawing. Use only figured dimensions. The Contractor shall verify all dimensions on site, and report any discrepancies to the Architect before commencing work.

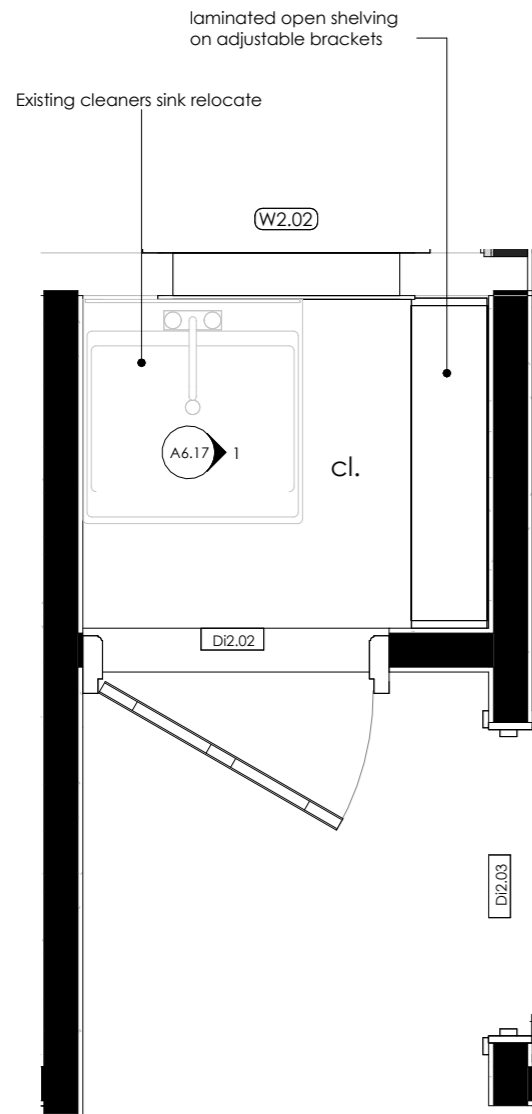

Boilers 4, 5 & 6 Control Room Enlarged Plan - cl.

1 : 20

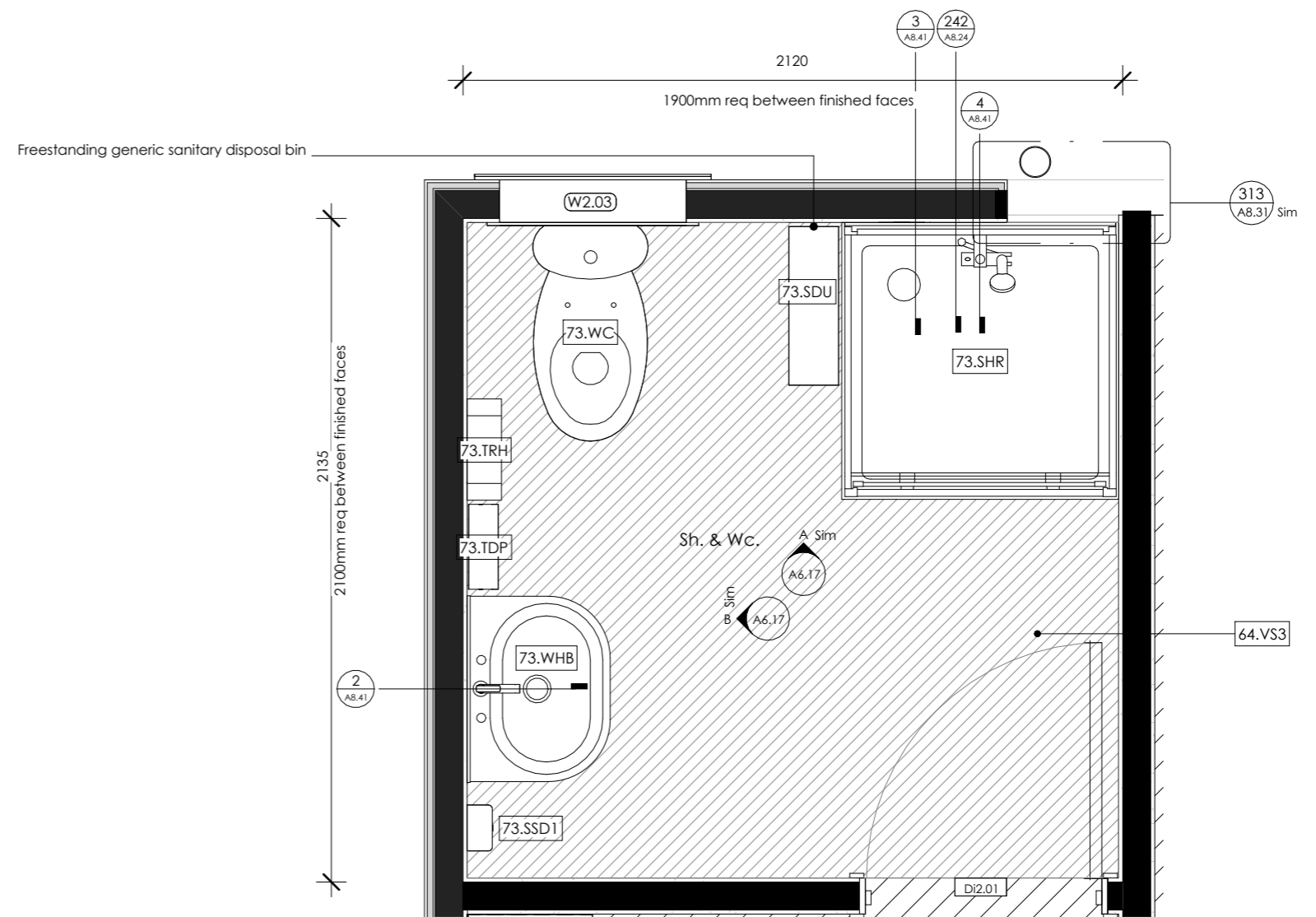

Boilers 4, 5 & 6 Control Room Enlarged Plan - Sh. & Wc.

1 : 20

Keynote Legend Per Page

Key Value	Keynote Text
73.MRR	Mirror: Custom Mirrox Polished Edge Mirror No Fixings @ 450 x 850mm.
73.SDU	Sanitary Disposal Unit.
73.SHR	Cubicle shower unit.
73.SSD1	Soap Dispensers: Mediclinics Surface Push-Button Liquid Soap Dispenser - Matte Black Epoxy
73.SSD2	Shower Soap Dispensers: Mediclinics Surface Push-Button Liquid Soap Dispenser - Matte Black Epoxy
73.TDP	Paper Towel dispensers.
73.TRH	Toilet Paper Holder.
73.WC	Toilet: Adesso Elevate Back to Wall Toilet Suite with Soft Close Seat Raised Button Set.
73.WHB	Accessible Wall Basin: Basin: Johnson Suisse Quado 450 Wall Hung Basin with Quado Shroud

General Notes:

1. This drawing shall be read in conjunction with all other drawings & specifications.
2. All work shall be strictly in accordance with the New Zealand Building Code, Local Territorial Authority Requirements, OSH Requirements & Regulations, and any other Statutory Requirements that may be applicable to this project.
3. All work shall be of best trade practice.
4. Do not scale from this drawing. Use only figured dimensions. The Contractor shall verify all dimensions on site, and report any discrepancies to the Architect before commencing work.

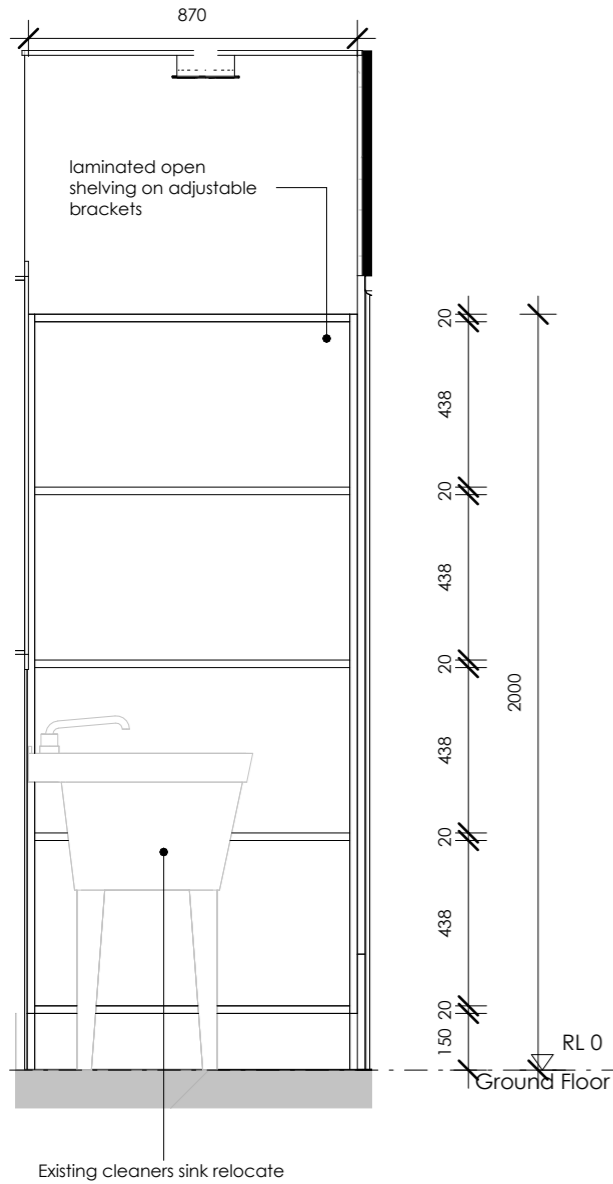

1 interior elevation cl.
A6.01 1 : 20 @ A3

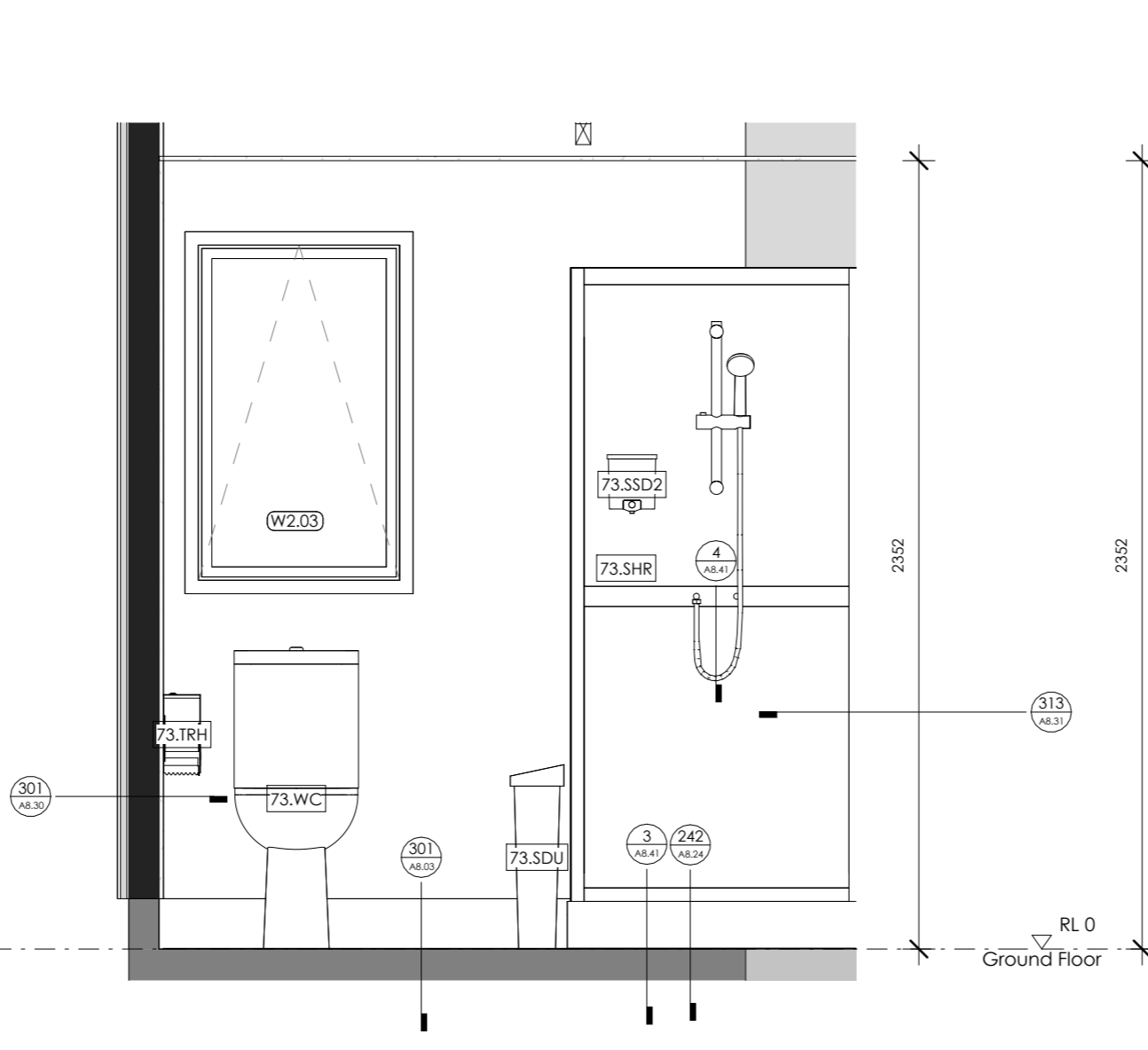

A interior elevation Female Lockers Sh. & Wc. A
A6.01 1 : 20 @ A3

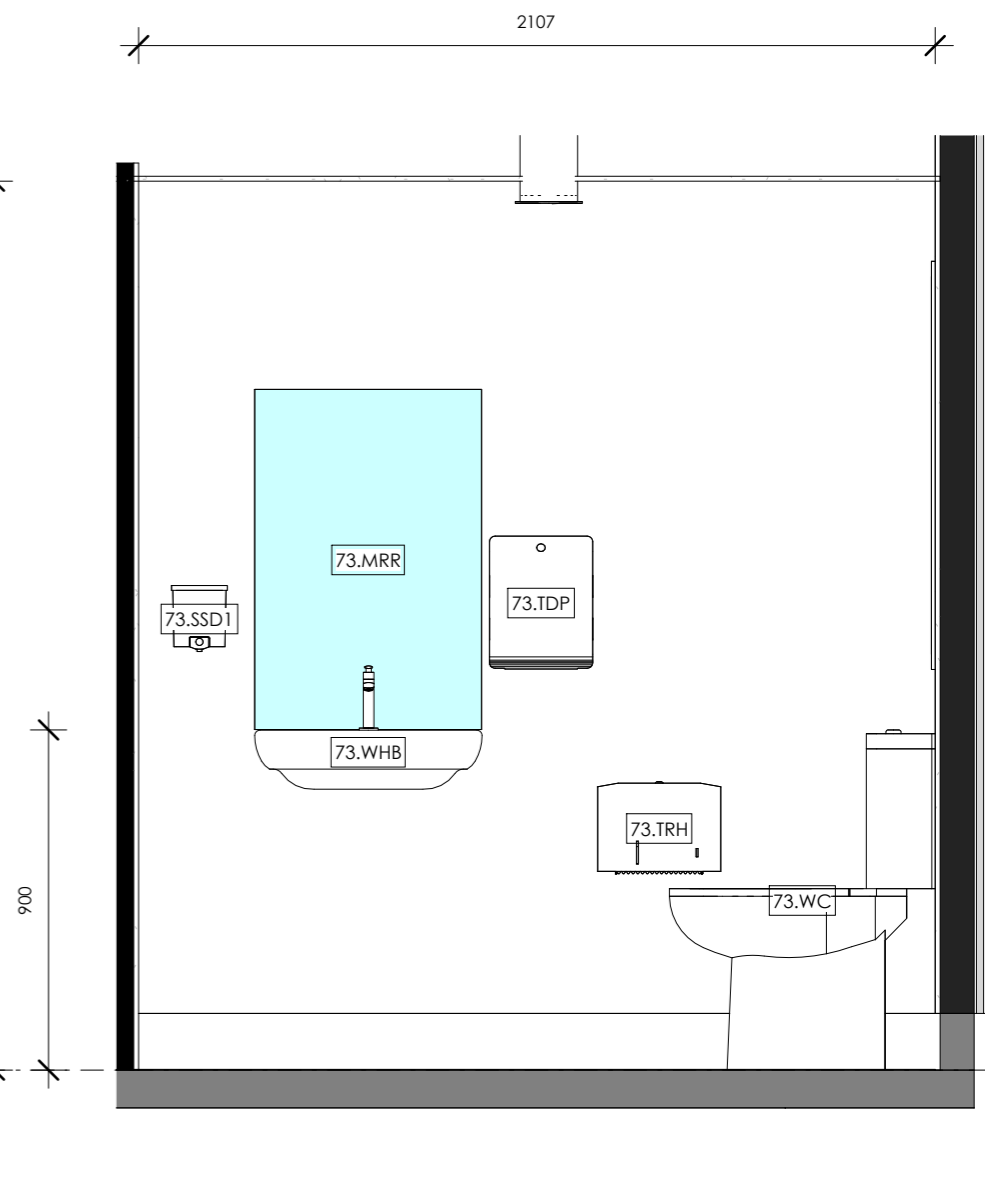

B interior elevation Female Lockers Sh. & Wc. B
A6.01 1 : 20 @ A3

- General Notes:**
1. This drawing shall be read in conjunction with all other drawings & specifications.
 2. All work shall be strictly in accordance with the New Zealand Building Code, Local Territorial Authority Requirements, OSH Requirements & Regulations, and any other Statutory Requirements that may be applicable to this project.
 3. All work shall be of best trade practice.
 4. Do not scale from this drawing. Use only figured dimensions. The Contractor shall verify all dimensions on site, and report any discrepancies to the Architect before commencing work.

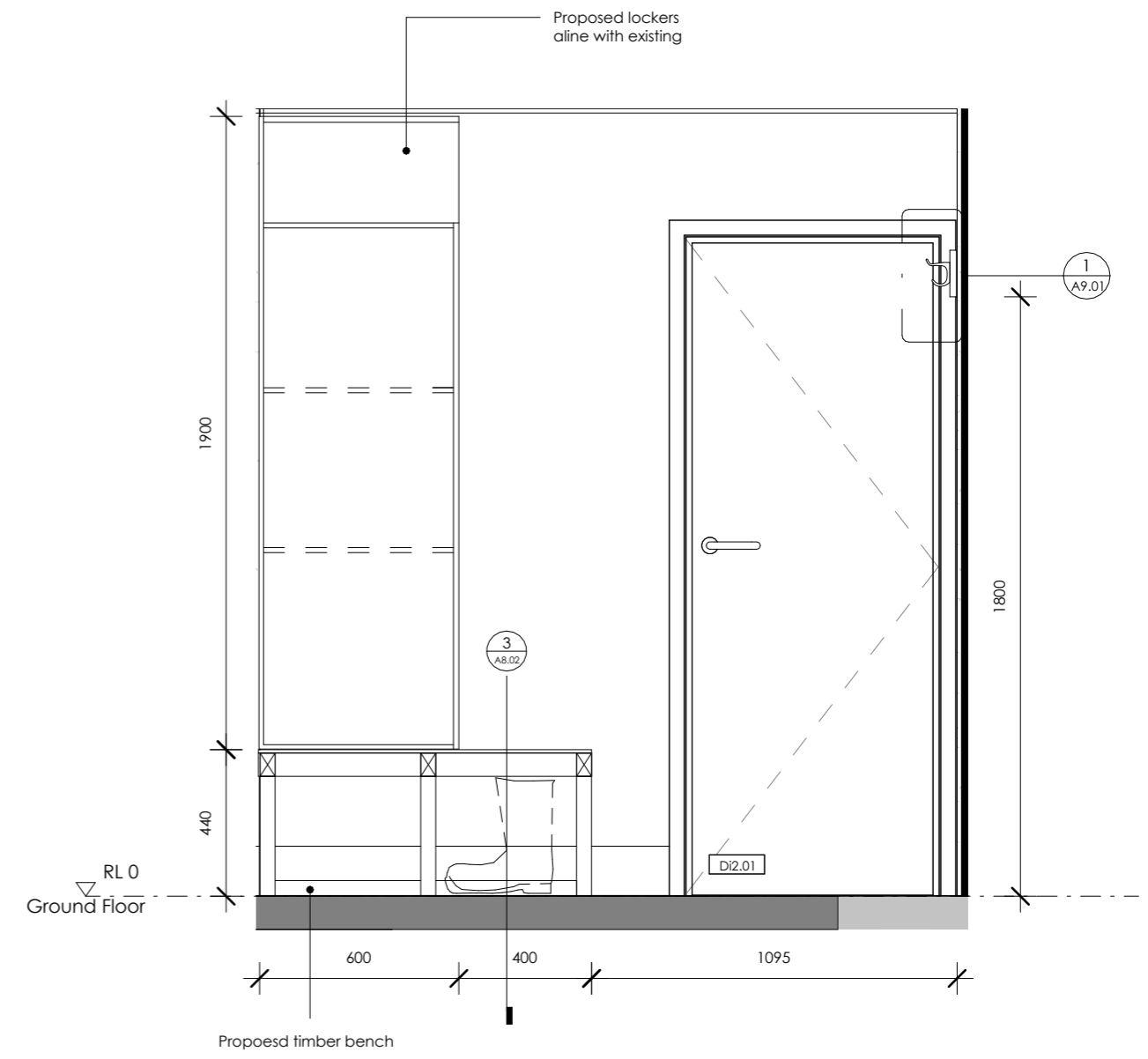
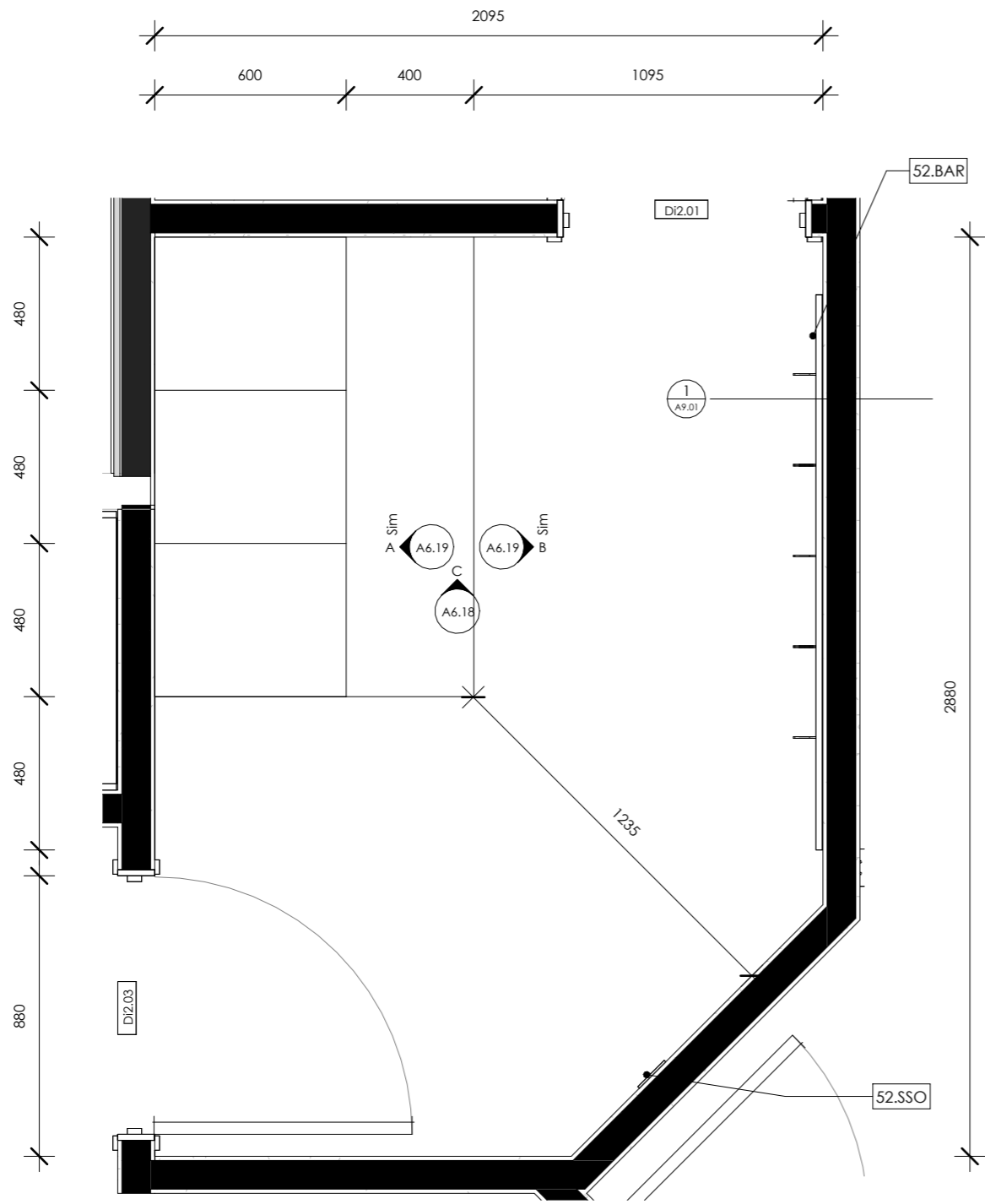

Boilers 1 & 2 Control Room Enlarged Plan - Female Lockers

1 : 20

C interior elevation Female Lockers C

A6.01 1 : 20 @ A3



Copyright:
 The copyright of this drawings remains the property of DLA Architects Limited and may only be used or re-used with DLA's prior written consent.

Project:
 Clondeboye Bio Mass Control Room & Amenities

Client:
 Fonterra Clondeboye

Drawing Title:
 Boilers 4, 5 & 6 Control Room Enlarged Plan - Female Lockers

REV.	DATE	REVISION DETAILS
1	28/08/24	Tender Issue
0	27/05/24	First Issue

Scale: 1 : 20 @ A3	Date: 29/08/24	Drawn: MX
Job No: C919	Designed: MA	Checked: CG
Drawing No: A6.18	Revision No: 1	

Keystone Legend Per Page	
Key Value	Keystone Text
52.SSO	SOCKET: Switched socket outlets.

- General Notes:**
1. This drawing shall be read in conjunction with all other drawings & specifications.
 2. All work shall be strictly in accordance with the New Zealand Building Code, Local Territorial Authority Requirements, OSH Requirements & Regulations, and any other Statutory Requirements that may be applicable to this project.
 3. All work shall be of best trade practice.
 4. Do not scale from this drawing. Use only figured dimensions. The Contractor shall verify all dimensions on site, and report any discrepancies to the Architect before commencing work.

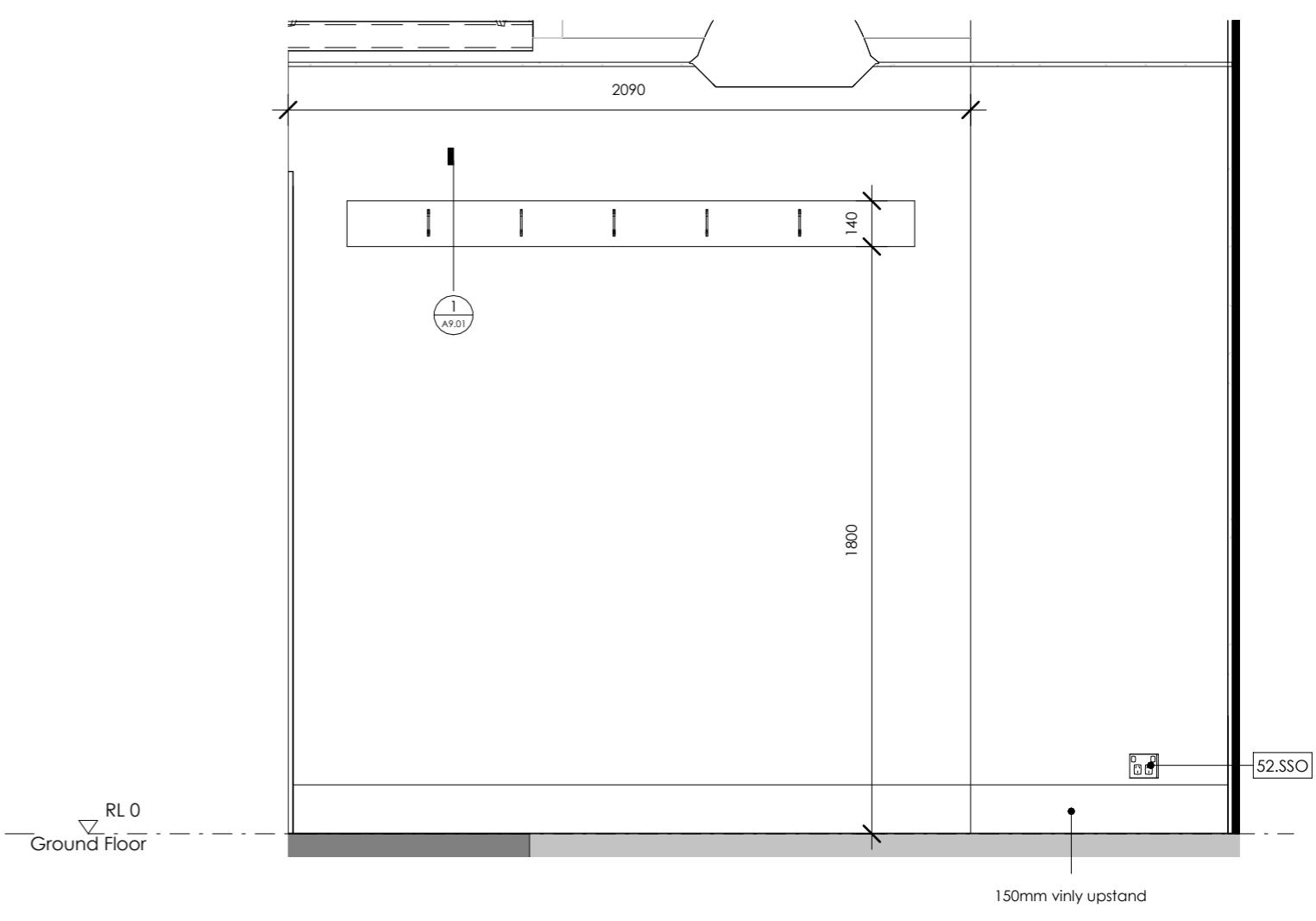
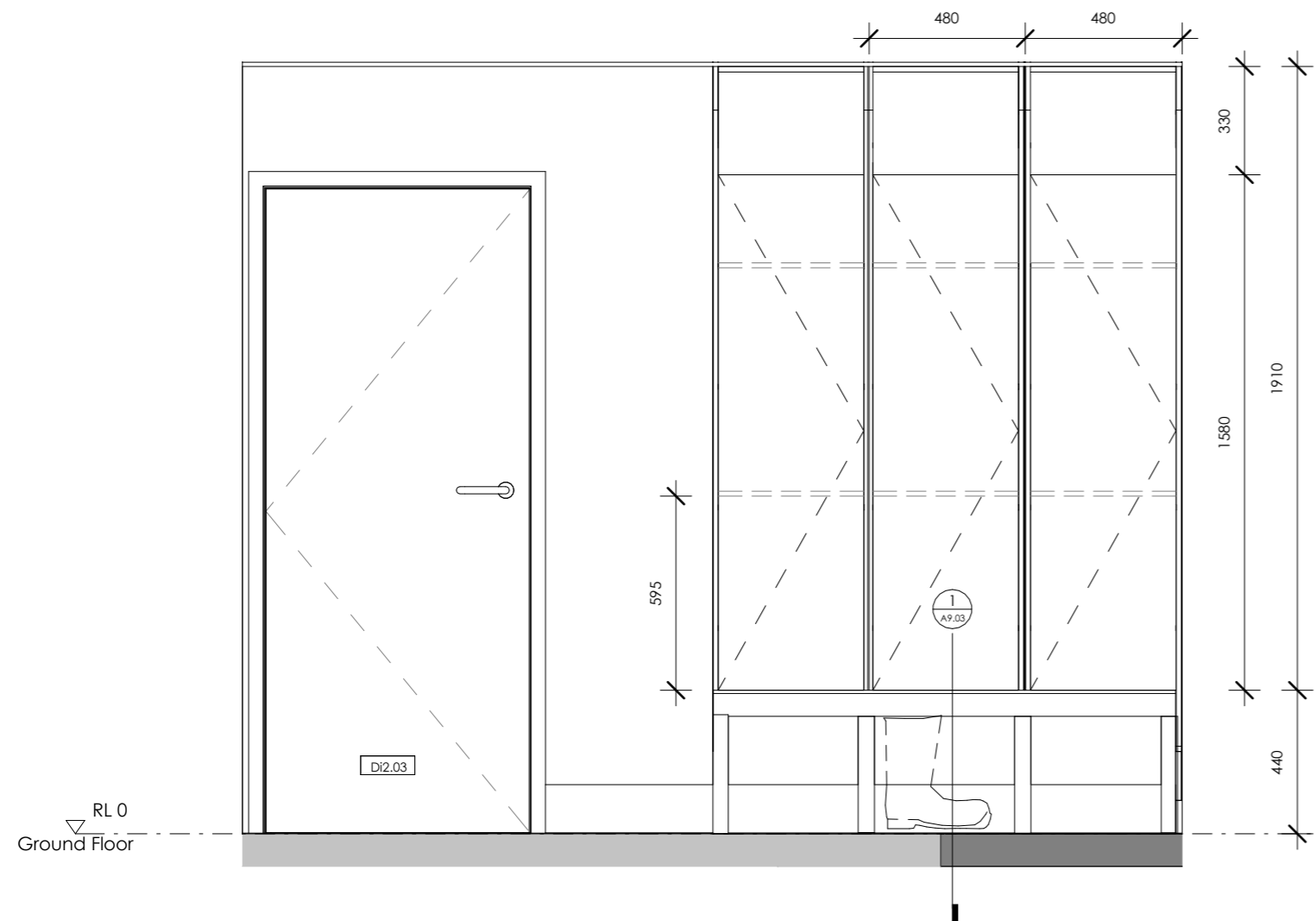

A interior elevation Female Lockers A
A6.01 1 : 20 @ A3

B interior elevation Female Lockers B
A5.02 1 : 20 @ A3



Copyright:
The copyright of this drawings remains the property of DLA Architects Limited and may only be used or re-used with DLA's prior written consent.

Project:
Clandeboyne Bio Mass Control Room & Amenities

Client:
Fonterra Clandeboyne

Drawing Title:
Boilers 4, 5 & 6 Control Room - Female Lockers Elevation
CAD File:

REV.	DATE	REVISION DETAILS
1	28/08/24	Tender Issue
0	27/05/24	First Issue

Scale: 1 : 20 @ A3	Date: 29/08/24	Drawn: MX
Job No: C919	Designed: MA	Checked: CG
Drawing No: A6.19	Revision No: 1	

- General Notes:**
1. This drawing shall be read in conjunction with all other drawings & specifications.
 2. All work shall be strictly in accordance with the New Zealand Building Code, Local Territorial Authority Requirements, OSH Requirements & Regulations, and any other Statutory Requirements that may be applicable to this project.
 3. All work shall be of best trade practice.
 4. Do not scale from this drawing. Use only figured dimensions. The Contractor shall verify all dimensions on site, and report any discrepancies to the Architect before commencing work.

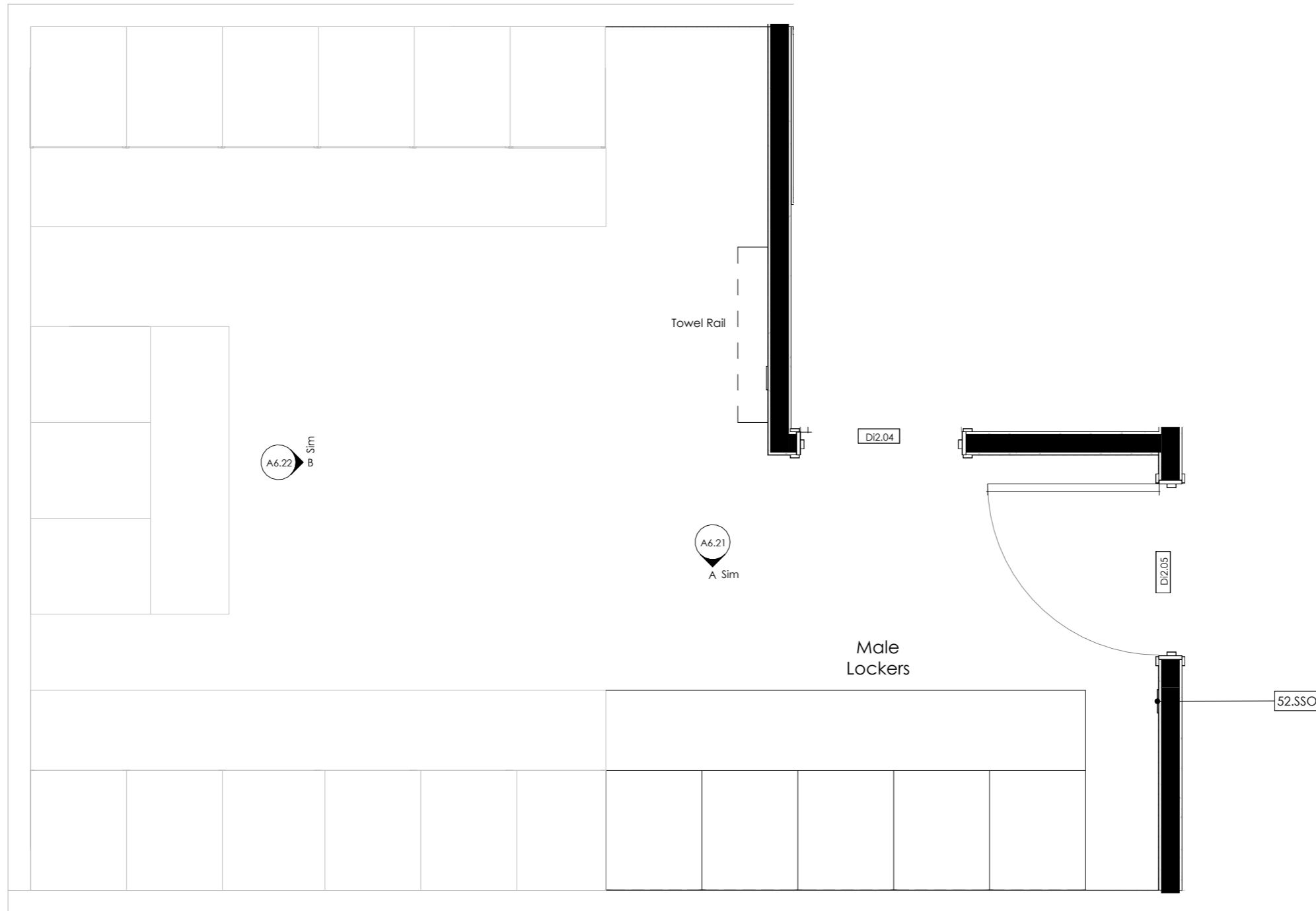

Boilers 1 & 2 Control Room Enlarged Plan - Male Lockers

1 : 25

REV.	DATE	REVISION DETAILS
1	28/08/24	Tender Issue
0	27/05/24	First Issue

Scale: 1 : 25 @ A3	Date: 29/08/24	Drawn: MX
Job No: C919	Designed: MA	Checked: CG
Drawing No: A6.20	Revision No: 1	

Keynote Legend Per Page

Key Value	Keynote Text
52.EPW	FINISH: existing plywood finish remain unchanged.
52.PWF	FINISH: proposed plywood finish align with existing.

General Notes:

1. This drawing shall be read in conjunction with all other drawings & specifications.
2. All work shall be strictly in accordance with the New Zealand Building Code, Local Territorial Authority Requirements, OSH Requirements & Regulations, and any other Statutory Requirements that may be applicable to this project.
3. All work shall be of best trade practice.
4. Do not scale from this drawing. Use only figured dimensions. The Contractor shall verify all dimensions on site, and report any discrepancies to the Architect before commencing work.

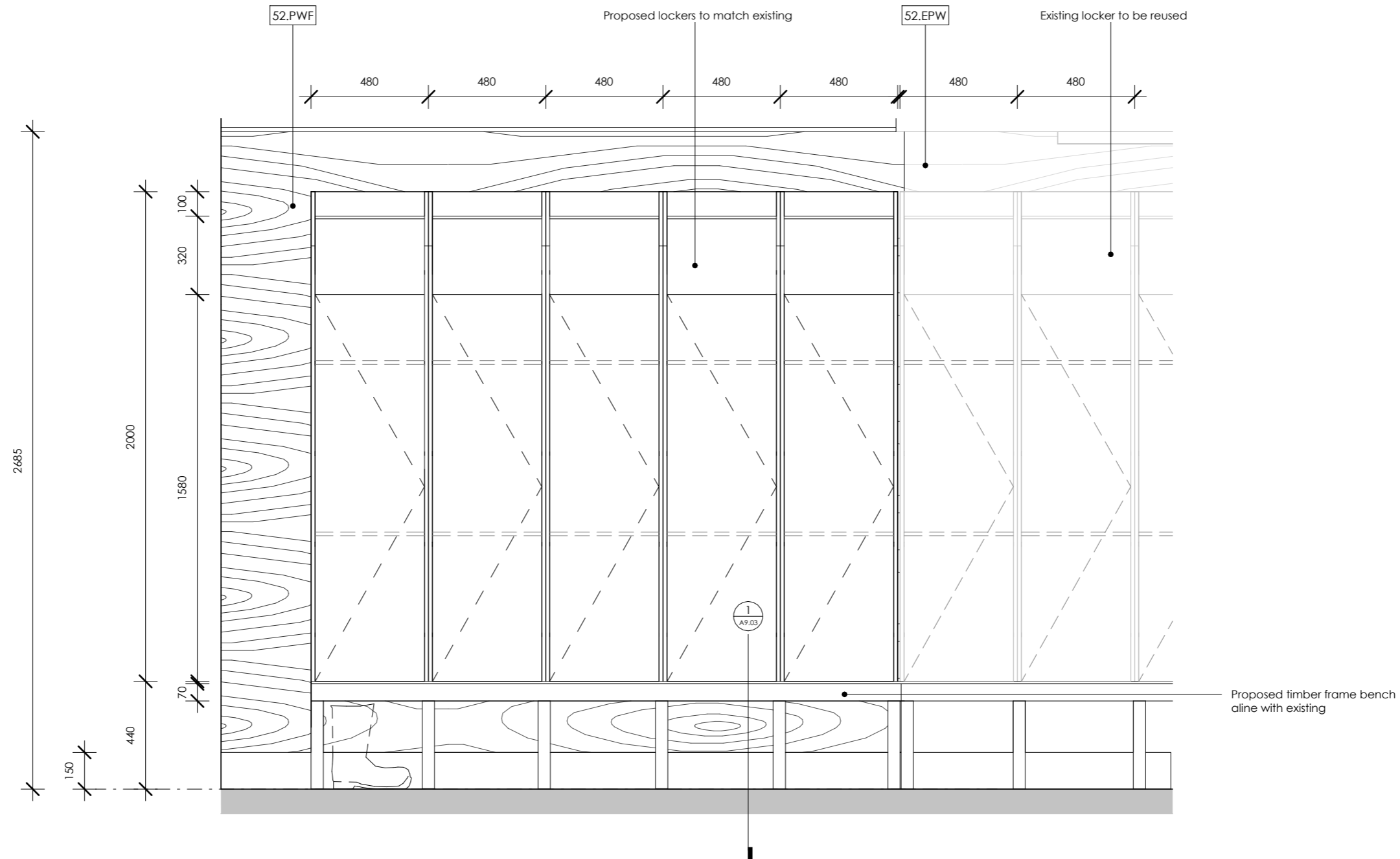

A interior elevation Male Lockers A
A6.01 1 : 20 @ A3

Keynote Legend Per Page

Key Value	Keynote Text
52.PWF	FINISH: proposed plywood finish align with existing.

General Notes:

1. This drawing shall be read in conjunction with all other drawings & specifications.
2. All work shall be strictly in accordance with the New Zealand Building Code, Local Territorial Authority Requirements, OSH Requirements & Regulations, and any other Statutory Requirements that may be applicable to this project.
3. All work shall be of best trade practice.
4. Do not scale from this drawing. Use only figured dimensions. The Contractor shall verify all dimensions on site, and report any discrepancies to the Architect before commencing work.

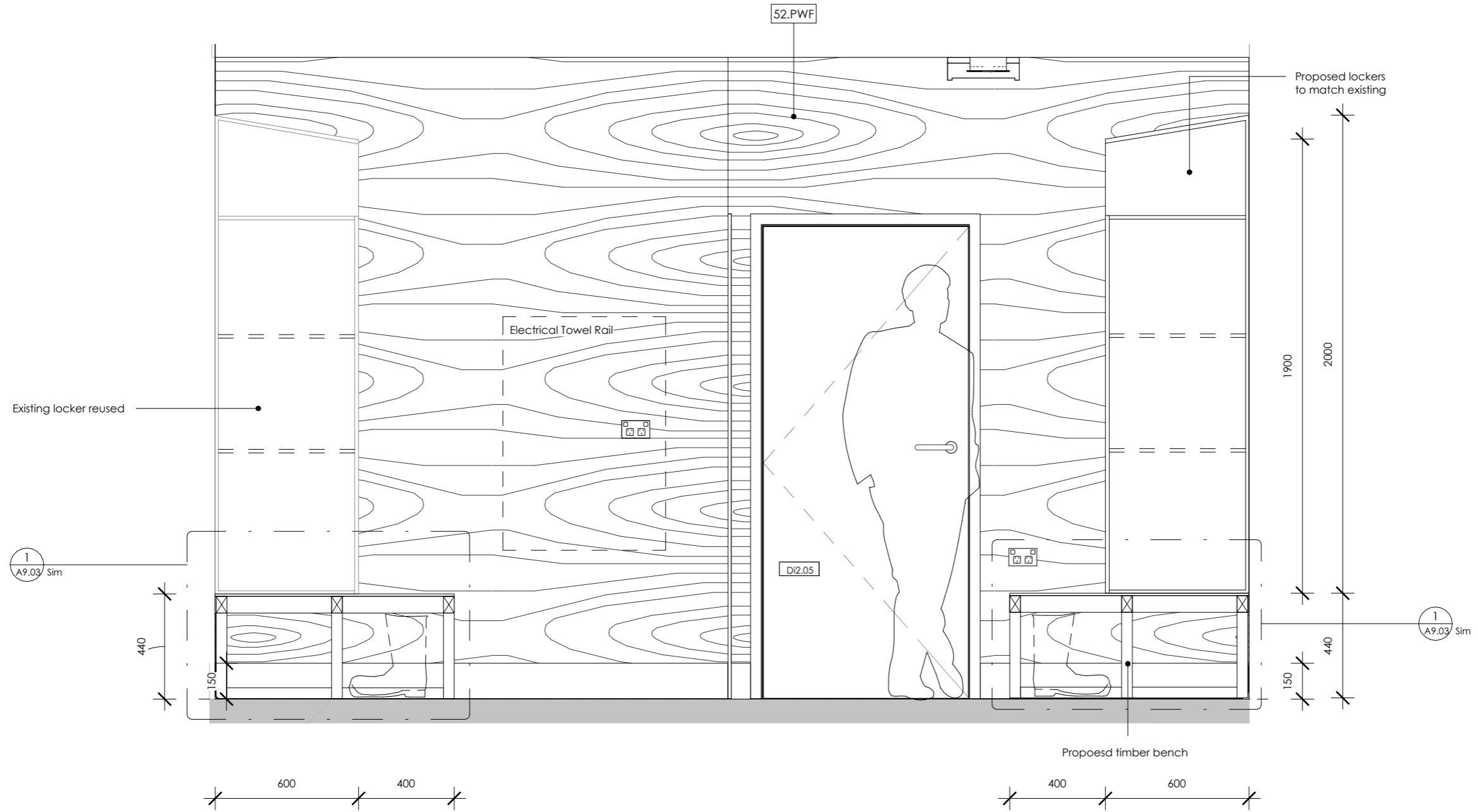

B interior elevation Male Lockers B
A6.01 1 : 20 @ A3



Copyright:
The copyright of this drawings remains the property of DLA Architects Limited and may only be used or re-used with DLA's prior written consent.

Project:
Clandeboye Bio Mass Control Room & Amenities

Client:
Fonterra Clandeboye

Drawing Title:
Boilers 4, 5 & 6 Control Room Enlarged Plan - Male Lockers Elevation B

REV.	DATE	REVISION DETAILS
1	28/08/24	Tender Issue
0	27/05/24	First Issue

Scale: 1 : 20 @ A3	Date: 29/08/24	Drawn: MX
Job No: C919	Designed: MA	Checked: CG
Drawing No: A6.22	Revision No: 1	

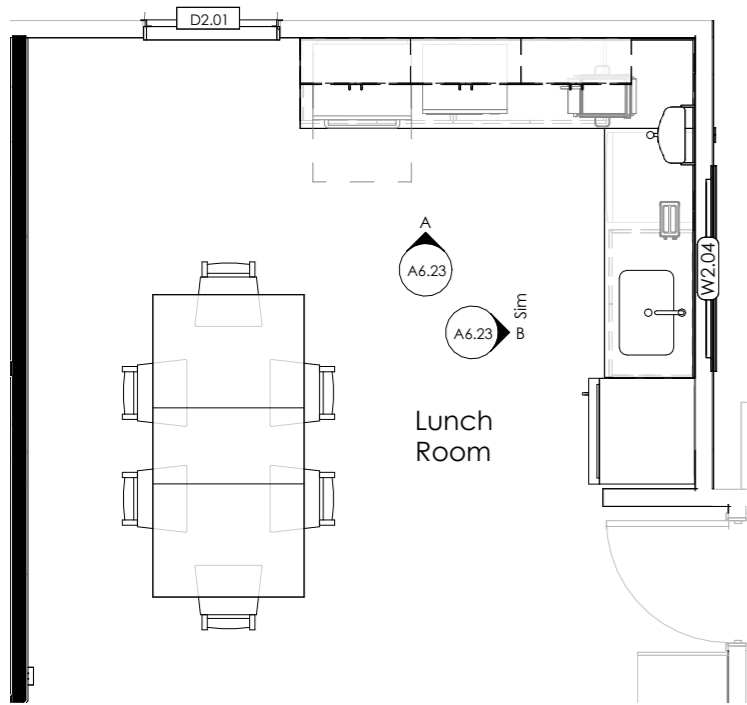

Boilers 1&2 Control Room Enlarged Plan - Lunch room

1 : 50

General Notes:

1. This drawing shall be read in conjunction with all other drawings & specifications.
2. All work shall be strictly in accordance with the New Zealand Building Code, Local Territorial Authority Requirements, OSH Requirements & Regulations, and any other Statutory Requirements that may be applicable to this project.
3. All work shall be of best trade practice.
4. Do not scale from this drawing. Use only figured dimensions. The Contractor shall verify all dimensions on site, and report any discrepancies to the Architect before commencing work.

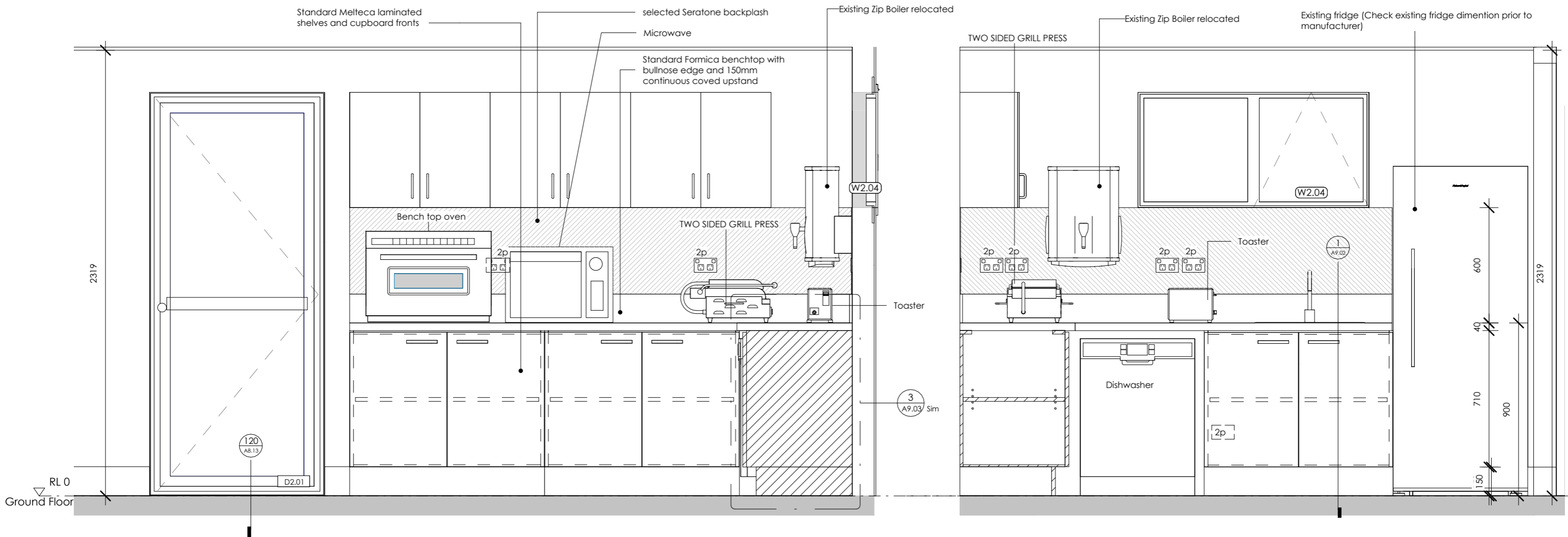

A interior elevation Lunch Room A
A6.01 1 : 20 @ A3

B interior elevation Lunch Room B
A5.02 1 : 20 @ A3



Copyright:
The copyright of this drawings remains the property of DLA Architects Limited and may only be used or re-used with DLA's prior written consent.

Project:
Clandeboyne Bio Mass Control Room & Amenities

Client:
Fonterra Clandeboyne

Drawing Title:
Boilers 4, 5 & 6 Control Room - Lunch Room Elevation
CAD File:

REV.	DATE	REVISION DETAILS
1	28/08/24	Tender Issue
0	27/05/24	First Issue

Scale: As indicated @ A3	Date: 29/08/24	Drawn: MX
Job No: C919	Designed: MA	Checked: CG
Drawing No: A6.23	Revision No: 1	

General Notes:

1. This drawing shall be read in conjunction with all other drawings & specifications.
2. All work shall be strictly in accordance with the New Zealand Building Code, Local Territorial Authority Requirements, OSH Requirements & Regulations, and any other Statutory Requirements that may be applicable to this project.
3. All work shall be of best trade practice.
4. Do not scale from this drawing. Use only figured dimensions. The Contractor shall verify all dimensions on site, and report any discrepancies to the Architect before commencing work.

Refer to truss and lintel design for lintel

Window Schedule General Note

- 1: Form opening sashed to window as indicated
- 2: Confirm dimensions on site prior to manufacture of joinery units
- 3: Glazing to comply with NZS 4223
- 4: Refer to Door & Window details.

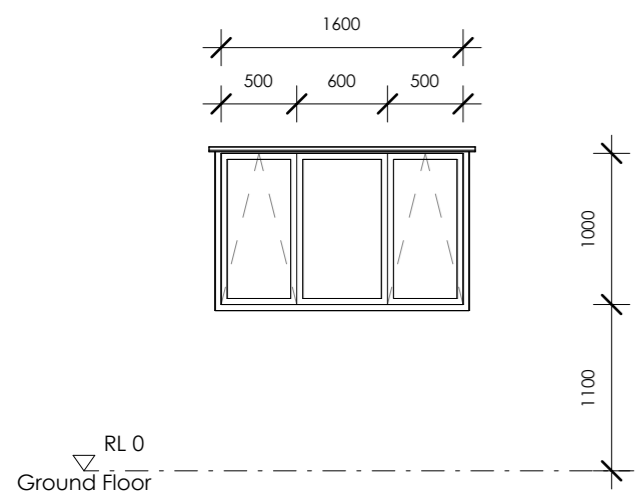

W1.1
Window Suit: DLA - APL Metro Series, Window 1600*1000 2
Reveals: Timber Reveals
Glazing Type: Metro Glass Double Glazed insulated glass unit - comply with NZS4223.
Trims: Trims...

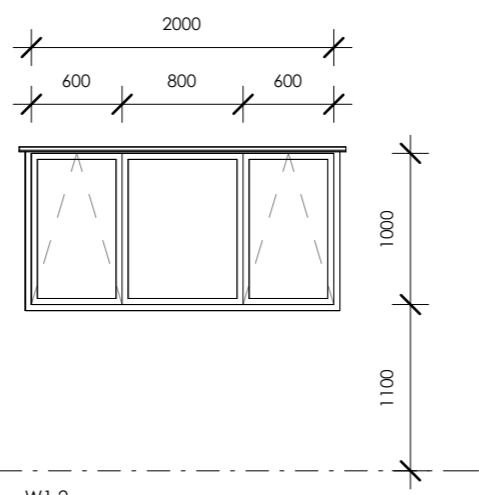

W1.2
Window Suit: DLA - APL Metro Series, Window 2000*1000
Frame finish: APL Metro Series powdercoated aluminium frame
Reveals: Timber Reveals
Glazing Type: Metro Glass Double Glazed insulated glass unit - comply with NZS4223.
Trims: Trims...

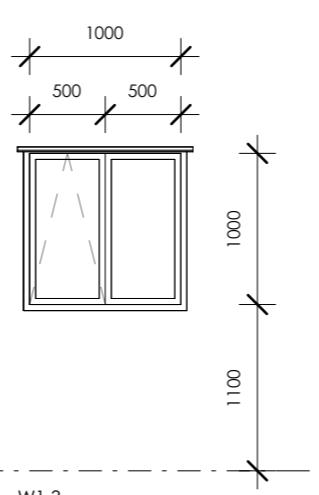

W1.3
Window Suit: DLA - APL Metro Series, Window 1000*1000
Frame finish: APL Metro Series powdercoated aluminium frame
Reveals: Timber Reveals
Glazing Type: Metro Glass Double Glazed insulated unit - comply with NZS4223
Trims: Trims...

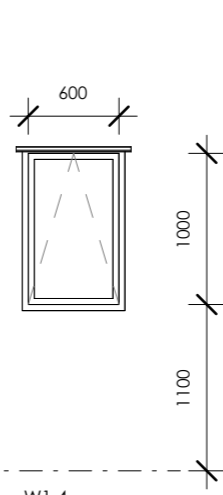

W1.4
Window Suit: DLA - APL Metro Series, Window, 600*1000
Frame finish: APL Metro Series powdercoated aluminium frame
Reveals: Timber Reveals
Glazing Type: Metro Glass Double Glazed insulated glass unit - comply with NZS4223.
Trims: Trims

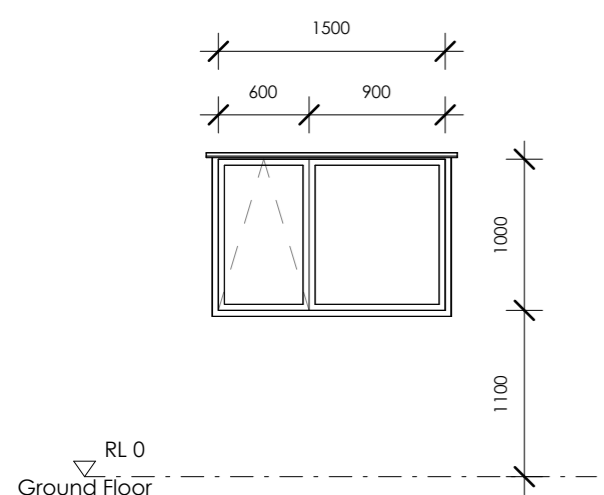

W1.5
Window Suit: DLA - APL Metro Series, Window 1500*1000
Frame finish: APL Metro Series powdercoated aluminium frame
Reveals: Timber Reveals
Glazing Type: Metro Glass Double Glazed insulated glass unit - comply with NZS4223.
Trims: Trims

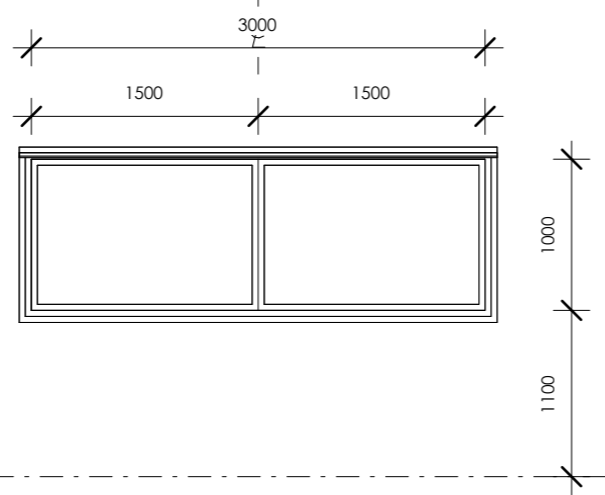

W1.6
Window Suit: DLA - APL Metro Series, Window 3000*1000
Frame finish: APL Metro Series powdercoated aluminium frame
Reveals: Timber Reveals
Glazing Type: Metro Glass Double Glazed insulated glass unit - comply with NZS4223.

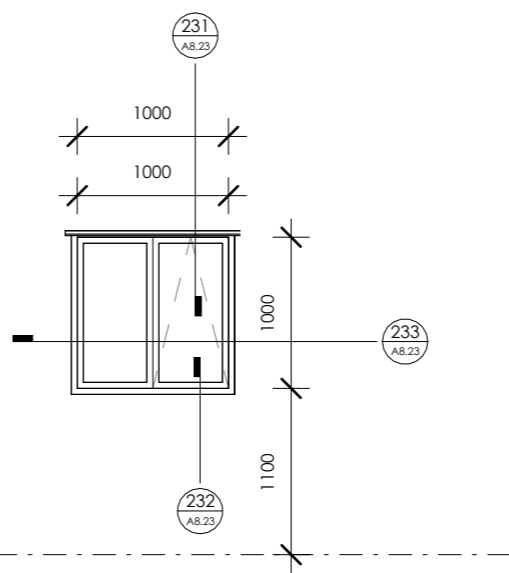

W1.8
Window Suit: DLA - APL Metro Series, Window 1000*1000
Frame finish: APL Metro Series powdercoated aluminium frame
Reveals: Timber Reveals
Glazing Type: Metro Glass Double Glazed insulated unit - comply with NZS4223
Trims: Trims...

Boiler Room 1&2 Window Schedule

Window No.	Window Type	Width	Height	Sill Height	Location
W1.1	DLA - APL Metro Series, Window 1600*1000 2	1600	1000	1100	Boiler 1 & 2
W1.2	DLA - APL Metro Series, Window 2000*1000	2000	1000	1100	Boiler 1 & 2
W1.3	DLA - APL Metro Series, Window 1000*1000	1000	1000	1100	Boiler 1 & 2
W1.4	DLA - APL Metro Series, Window, 600*1000	600	1000	1100	Boiler 1 & 2
W1.5	DLA - APL Metro Series, Window 1500*1000	1500	1000	1100	Boiler 1 & 2
W1.6	DLA - APL Metro Series, Window 3000*1000	3000	1000	1100	Boiler 1 & 2
W1.8	DLA - APL Metro Series, Window 1000*1000	1000	1000	1100	Boiler 1 & 2



Copyright:
The copyright of this drawings remains the property of DLA Architects Limited and may only be used or re-used with DLA's prior written consent.

Project:
Clandeboyne Bio Mass Control Room & Amenities

Client:
Fonterra Clandeboyne

Drawing Title:
Exterior Window Schedule Control Room Boilers - 1 & 2
CAD File:

REV.	DATE	REVISION DETAILS
1	28/08/24	Tender Issue
0	27/05/24	First Issue

Scale: 1 : 50 @ A3	Date: 29/08/24	Drawn: MX
Job No: C919	Designed: MA	Checked: CG
Drawing No: A7.00	Revision No: 1	

- General Notes:**
1. This drawing shall be read in conjunction with all other drawings & specifications.
 2. All work shall be strictly in accordance with the New Zealand Building Code, Local Territorial Authority Requirements, OSH Requirements & Regulations, and any other Statutory Requirements that may be applicable to this project.
 3. All work shall be of best trade practice.
 4. Do not scale from this drawing. Use only figured dimensions. The Contractor shall verify all dimensions on site, and report any discrepancies to the Architect before commencing work.

Refer to truss and lintel design for lintel

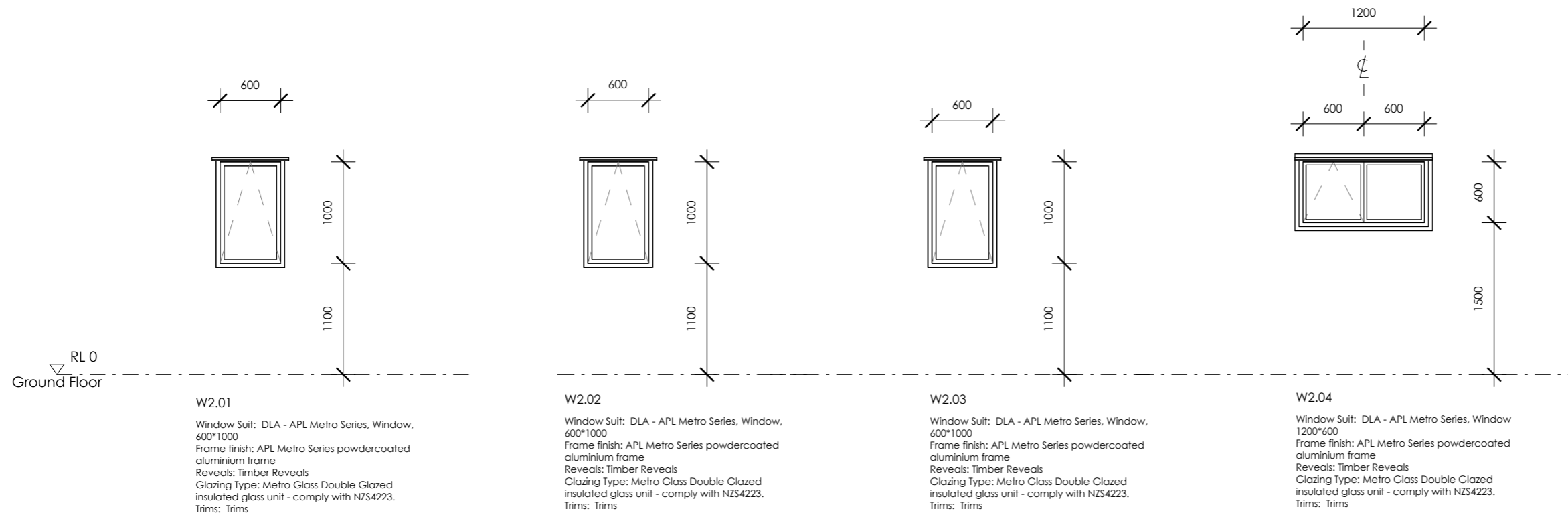

Window Schedule General Note

- 1: Form opening sashed to window as indicated
- 2: Confirm dimensions on site prior to manufacture of joinery units
- 3: Glazing to comply with NZS 4223
- 4: Refer to Door & Window details.

Boiler 4,5 & 6 Window Schedule					
Window No.	Window Type	Width	Height	Sill Height	Comments
W2.01	DLA - APL Metro Series, Window, 600*1000	600	1000	1100	Boiler 4,5 & 6
W2.02	DLA - APL Metro Series, Window, 600*1000	600	1000	1100	Boiler 4,5 & 6
W2.03	DLA - APL Metro Series, Window, 600*1000	600	1000	1100	Boiler 4,5 & 6
W2.04	DLA - APL Metro Series, Window 1200*600	1200	600	1500	Boiler 4,5 & 6

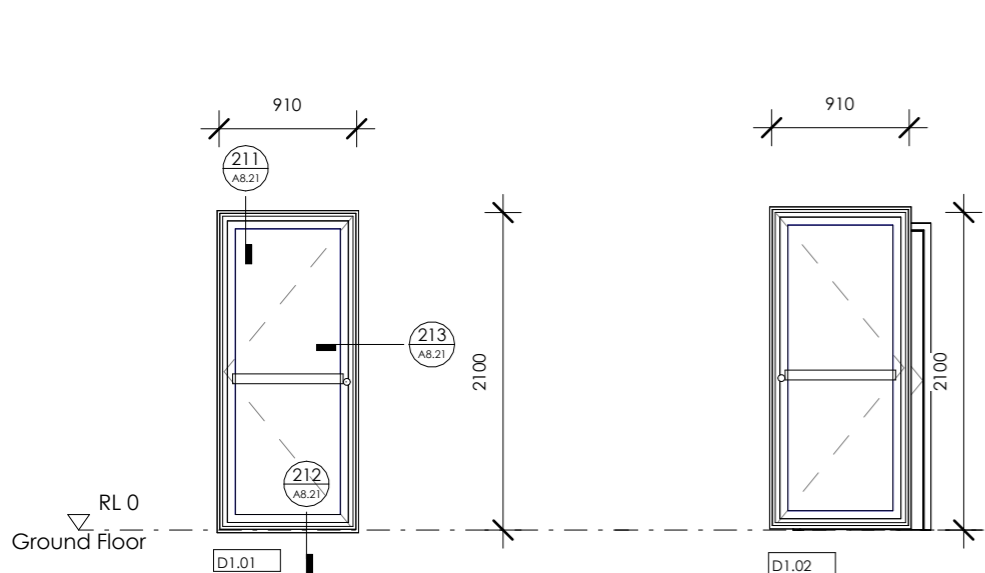

D1.01
METRO Thermal Heart Series hinge door, open in. 910 x 2100.
Frame Material: Aluminium frame powder coated
Closer: Door Closer 2-6 Strength.
Glazing Type: Double Glazed A grade safety - to comply with NZS4223
With Access Control

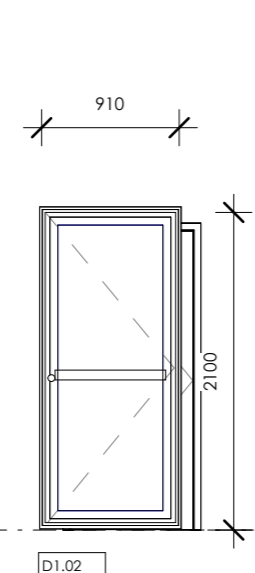

D1.02
METRO Thermal Heart Series hinge door, open in. 910 x 2100
Frame Material: Powdercoated Aluminium APL Series door frame
Closer: Door Closer 2-6 Strength.
Glazing Type: Double Glazed A grade safety - to comply with NZS4223
With access control

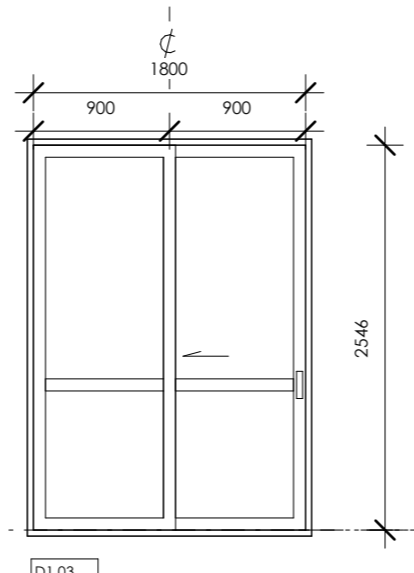

D1.03
APL Metro Series Thermal Heart Slider, 1800 x 2547
Frame Material: Powdercoated Aluminium APL Series door frame.
Closer: Door Closer 2-6 Strength.
Glazing Type: Double Glazed A grade safety - to comply with NZS4223
With access control

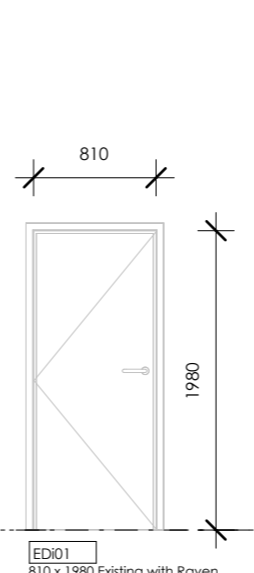

EDI01
810 x 1980 Existing with Raven sound proof upgrade.
Thickness: 48mm
Frame Material: Existing Frame
Noise control hardware: Raven RSS-006 Acoustic Door Seal Set (RAVEN RP10si, RAVEN RP27Si Automatic Door Bottom Seals, with RP124 Perimeter Seals).
Hardware: Existing door remain with Raven Acoustic system upgrade
With Access Control

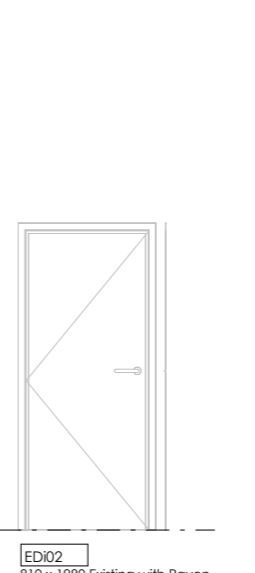

EDI02
810 x 1980 Existing with Raven sound proof upgrade.
Thickness: 48mm
Frame Material: Existing Frame
Noise control hardware: Raven RSS-006 Acoustic Door Seal Set (RAVEN RP10si, RAVEN RP27Si Automatic Door Bottom Seals, with RP124 Perimeter Seals).
Hardware: Existing door remain with Raven Acoustic system upgrade
With Access Control

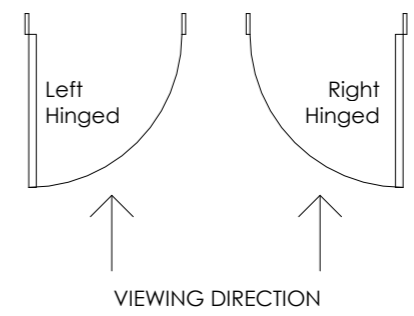

NOTE: Refer Floor Plans for all hing side and door swing directions

- General Notes:**
1. This drawing shall be read in conjunction with all other drawings & specifications.
 2. All work shall be strictly in accordance with the New Zealand Building Code, Local Territorial Authority Requirements, OSH Requirements & Regulations, and any other Statutory Requirements that may be applicable to this project.
 3. All work shall be of best trade practice.
 4. Do not scale from this drawing. Use only figured dimensions. The Contractor shall verify all dimensions on site, and report any discrepancies to the Architect before commencing work.

Door Schedule General Note

- 1: Confirm dimensions on site prior to manufacture of joinery units.
- 2: Glazing to comply with NZS4223.
- 3: Refer to Door & Window Detail.

Refer to hardware schedule for selections

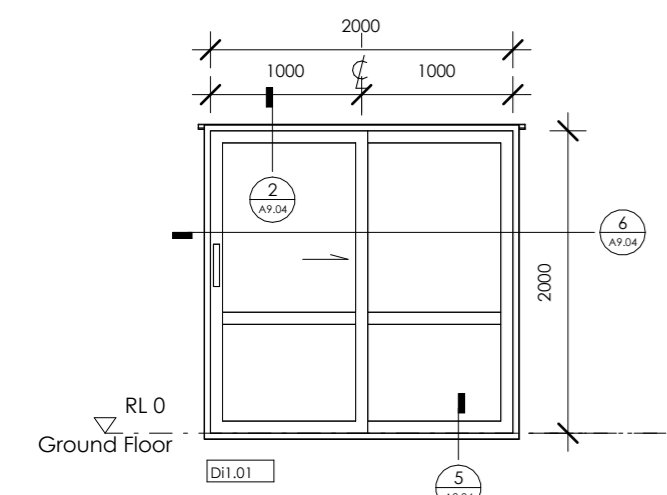

Di1.01
APL Metro Series Slider, 2000 x 2000 Interior
Frame Material: Double Aluminium powder coated
Glazing Type: Single Glazed 10.38mm laminated glass (A grade safety) clear - to comply with NZS4223

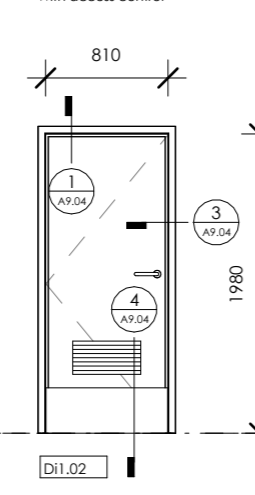

Di1.02
810 x 1980
Thickness: 38mm
Material and finish: Timber solid core with enamel painted finish
Frame Material: Timber frame
Closer: Door Closer 1-4 Strength Sil.
Noise control hardware: Raven RP2B 1000M Brush Strip Seal.
Hardware: 300mm Kickplate.
Door grilles

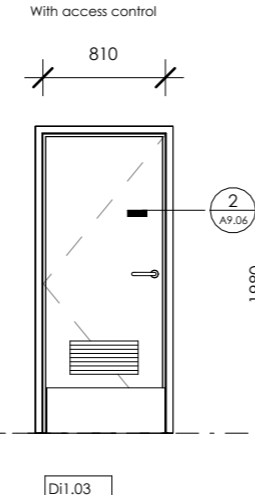

Di1.03
810 x 1980
Thickness: 38mm
Material and finish: Timber solid core with enamel painted finish
Frame Material: Timber frame
Hardware: 300mm Kickplate.
Door grilles

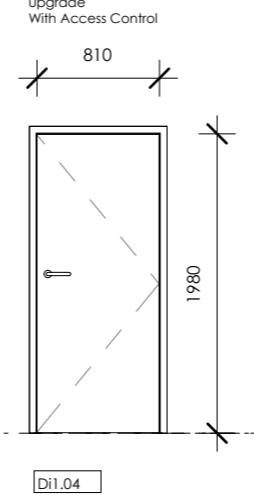

Di1.04
810 x 1980
Thickness: 38mm
Material and finish: Timber solid core with enamel painted finish
Frame Material: Timber frame

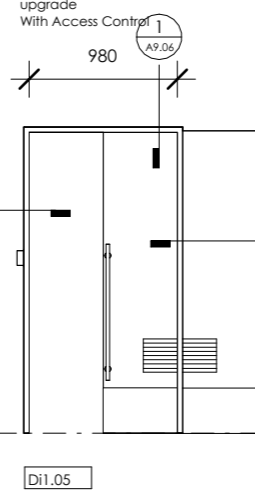

Di1.05
980x2000
Material and finish: Solid core partical board sliding door
Frame Material: powdercoated aluminium suite.
Hardware: 300mm Kickplate.
Door grilles

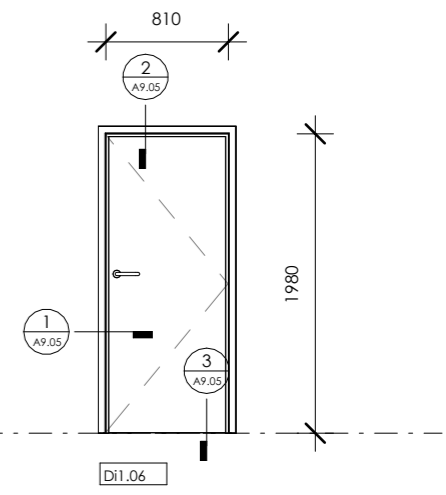

Di1.06
810 x 1980 Noise reduction door
Thickness: 48mm
Material and finish: Timber solid core with timber frame.
Frame Material: Timber Frame
Noise control hardware: Raven RSS-006 Acoustic Door Seal Set (RAVEN RP10si, RAVEN RP27Si Automatic Door Bottom Seals, with RP124 Perimeter Seals).

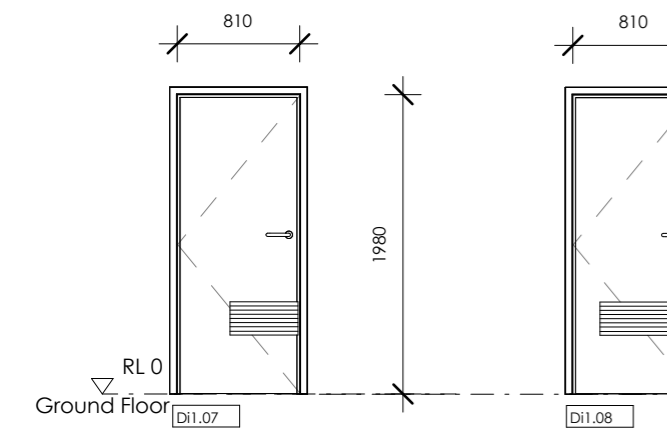

Di1.07
810 x 1980
Thickness: 38mm
Material and finish: Timber solid core with enamel painted finish
Frame Material: Timber frame
Noise control hardware: Raven RP2B 1000M Brush Strip Seal.
Hardware: Door grilles

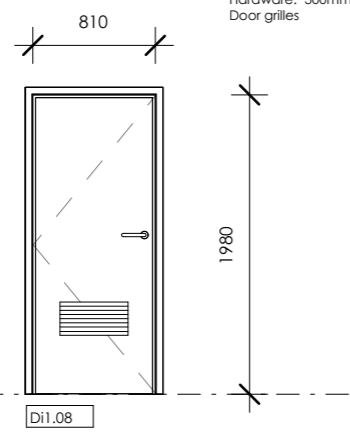

Di1.08
810 x 1980
Thickness: 38mm
Material and finish: Timber solid core with enamel painted finish
Frame Material: Timber frame
Noise control hardware: Raven RP2B 1000M Brush Strip Seal.
Hardware: Door grilles

Boiler Room 1&2 Door Schedule

Door No.	Location	Door Type	Wall Type	Access Control
Boiler Room 1&2 Exterior				
D1.01	Port	Glazed Hinge Door	9Axon 19 timber batten 6 RAB 140 Timber Stud double 13 Gib	With Access Control
D1.02	Lab	Glazed Hinge Door	9Axon 19 timber batten 6 RAB 140 Timber Stud double 13 Gib	With access control
D1.03	Lobby	Glass sliding door	Existing wall	With access control
Boiler Room 1&2 Exterior: 3				
Boiler Room 1&2 Interior				
Di1.01	Office	Glass sliding door	13 Gib 90 timber stud double 13 Gib	
Di1.02	Lobby		13 Gib 90 timber stud 13Aqualine	
Di1.03	Wc.		13 Gib Aqualine 90 timber stud 13 Gib Aqualine	
Di1.04	Store		double 13 Gib 90 timber stud 13 Gib	
Di1.05	ACC Toilet	Cavity sliding door	13 Gib Aqualine 90 timber stud 13 Aualine	
Di1.06	Meeting Room		double 13 Gib 90 timber stud double 13 Gib	
Di1.07	Lab		double 13 Gib 90 timber stud 13 Gib	
Di1.08	Document Storage		13 Gib 90 timber stud 13 Gib	
EDI01	Lobby to Office	Existing Door Upgrade	Existing wall	With Access Control
EDI02	Control Room	Existing Door Upgrade	Existing wall	With Access Control

Boiler Room 1&2 Interior: 10
Total doors in Boilers 1 & 2 Control Room: 13



Copyright:
The copyright of this drawings remains the property of DLA Architects Limited and may only be used or re-used with DLA's prior written consent.

Project:
Clandeboy Bio Mass Control Room & Amenities

Client:
Fonterra Clandeboy

Drawing Title:
Door Schedule Control Room Boilers - 1 & 2
CAD File:

REV.	DATE	REVISION DETAILS
1	28/08/24	Tender Issue
0	27/05/24	First Issue

Scale: As indicated @ A3	Date: 29/08/24	Drawn: MX
Job No: C919	Designed: MA	Checked: CG
Drawing No: A7.10	Revision No: 1	

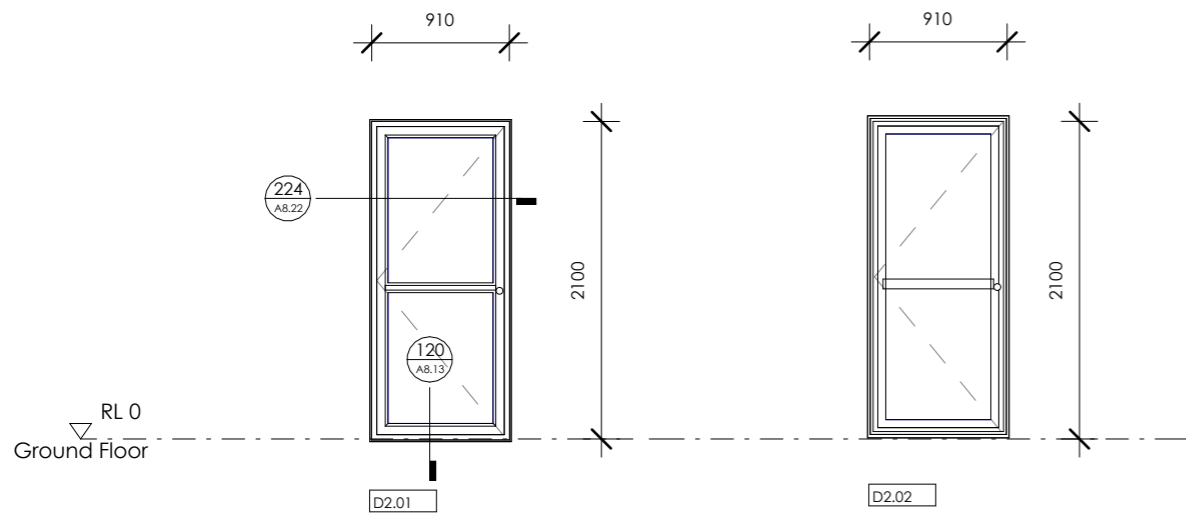

METRO Thermal Heart Series hinge door, open in. 910 x 2100.
 Frame Material: Powdercoated Aluminium APL Series door frame
 Closer: Door Closer 2-6 Strength.
 Glazing Type: Double Glazed A grade safety - to comply with NZS4223
 With Access Control

METRO Thermal Heart Series hinge door, open in. 910 x 2100.
 Closer: Door Closer 2-6 Strength.
 Glazing Type: Double Glazed A grade safety - to comply with NZS4223
 With Access Control

Door Schedule General Note

- 1: Confirm dimensions on site prior to manufacture of joinery units.
- 2: Glazing to comply with NZS4223.
- 3: Refer to Door & Window Detail.

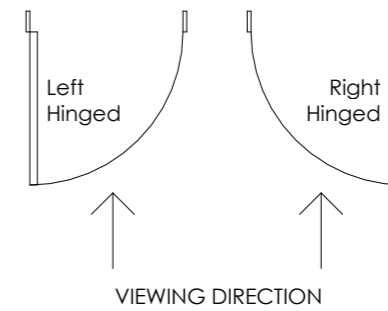

NOTE: Refer Floor Plans for all hing side and door swing directions

General Notes:

1. This drawing shall be read in conjunction with all other drawings & specifications.
2. All work shall be strictly in accordance with the New Zealand Building Code, Local Territorial Authority Requirements, OSH Requirements & Regulations, and any other Statutory Requirements that may be applicable to this project.
3. All work shall be of best trade practice.
4. Do not scale from this drawing. Use only figured dimensions. The Contractor shall verify all dimensions on site, and report any discrepancies to the Architect before commencing work.

Refer to hardware schedule for selections

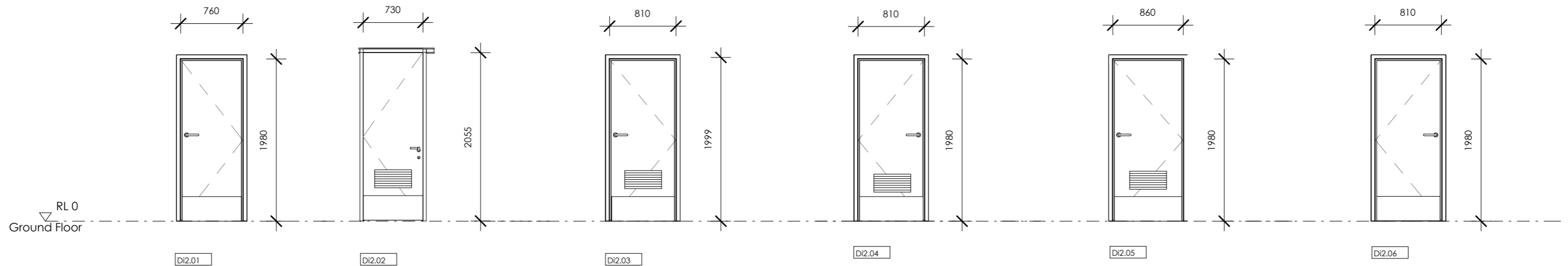

760 x 1980
 Thickness: 38mm
 Material and finish: Timber solid core with timber finish
 Frame Material: Timber Frame
 Hardware: 300mm Kickplate.

Cavity Slider 730mm
 Thickness: 38mm
 Material and finish: Double Aluminium powder coated aluminium suite.
 Hardware: 300mm Kickplate.
 Door grilles

810 x 1980.
 Thickness: 38mm
 Material and finish: Timber solid core with enamel painted finish
 Frame Material: Timber Frame
 Closer: Door Closer 1-4 Strength Sil.
 Noise control hardware: Raven RP2B 1000M Brush Strip Seal.
 Hardware: 300mm Kickplate.
 Door grilles

810 x 1980
 Thickness: 38mm
 Material and finish: Timber solid core with enamel painted finish
 Frame Material: Timber Frame
 Hardware: 300mm Kickplate.
 Door grilles

860 x 1980
 Thickness: 38mm
 Material and finish: Timber solid core with timber finish
 Frame Material: Timber Frame
 Closer: Door Closer 1-4 Strength Sil.
 Noise control hardware: Raven RP2B 1000M Brush Strip Seal.
 Hardware: 300mm Kickplate.
 Door grilles

810 x 1980 Existing door relocate
 Thickness: 38mm
 Material and finish: Existing timber solid core with enamel painted finish over existing door.
 Frame Material: Timber Frame
 Noise control hardware: Raven RP2B 1000M Brush Strip Seal.
 Hardware: 300mm Kickplate.

Boiler Room 4,5 & 6 Door Schedule

Door No.	Location	Door Type	Wall Type	Manufacturer
Boiler Room 4,5 & 6 Exterior				
D2.01	Lunch Room	Glazed Hinge Door	Existing wall	With Access Control
D2.02	Lobby	Glazed Hinge Door	Existing wall	With Access Control
Boiler Room 4,5 & 6 Exterior: 2				
Boiler Room 4,5 & 6 Interior				
Di2.01	Sh. & Wc.		13 Gib 90 timber stud 13Aqualine	
Di2.02	cl.		13 Gib 90 timber stud 13Aqualine	
Di2.03	Female Lockers		13 Gib 90 timber stud 13 Gib	
Di2.04	Sh. & Wc.		Timber finish 90 stud 13 Aqualine	
Di2.05	Male Lockers		13 Gib 90 timber stud Timber finish	
Di2.06	Lobby	Existing Door Relocate and upgrade	13 Gib 90 timber stud 13 Gib	

Boiler Room 4,5 & 6 Interior: 6
 Total doors in Boilers 1 & 2 Control Room: 8



Copyright:
 The copyright of this drawings remains the property of DLA Architects Limited and may only be used or re-used with DLA's prior written consent.

Project:
Clandeboy Bio Mass Control Room & Amenities

Client:
Fonterra Clandeboy

Drawing Title:
Door Schedule Control Room Boilers - 4, 5 & 6
 CAD File:

REV.	DATE	REVISION DETAILS
1	28/08/24	Tender Issue
0	27/05/24	First Issue

Scale: As indicated @ A3	Date: 29/08/24	Drawn: MX
Job No: C919	Designed: MA	Checked: CG
Drawing No: A7.11	Revision No: 1	

Keynote Legend Per Page

Key Value	Keynote Text
31.M12	M12 Bolt.
32.MES	MESH: 500E grade mesh with 30mm min. top cover.
32.PSL	Proposed paving slab.
38.TP1	TIMBER POST: Prolam 88x88mm, H5 Visual (PLPH5-100) post with 3 coat paint finish, footing size refer to detail drawing.

General Notes:

1. This drawing shall be read in conjunction with all other drawings & specifications.
2. All work shall be strictly in accordance with the New Zealand Building Code, Local Territorial Authority Requirements, OSH Requirements & Regulations, and any other Statutory Requirements that may be applicable to this project.
3. All work shall be of best trade practice.
4. Do not scale from this drawing. Use only figured dimensions. The Contractor shall verify all dimensions on site, and report any discrepancies to the Architect before commencing work.

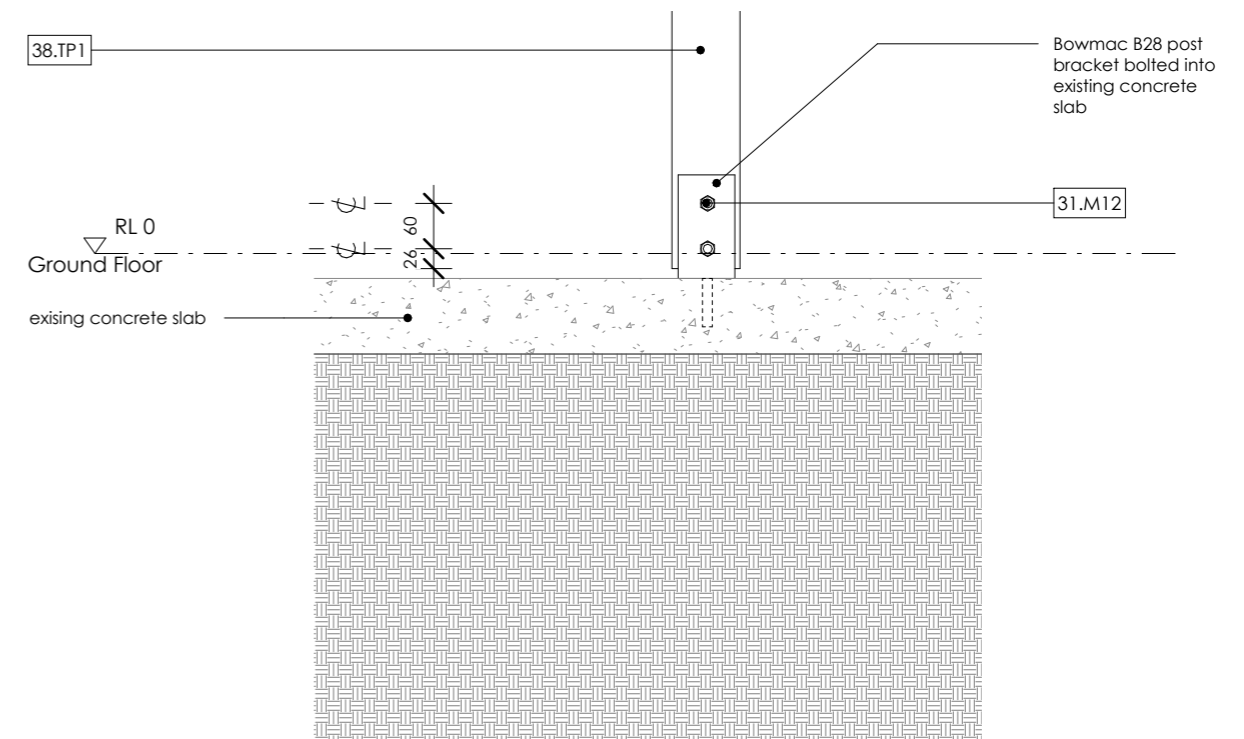
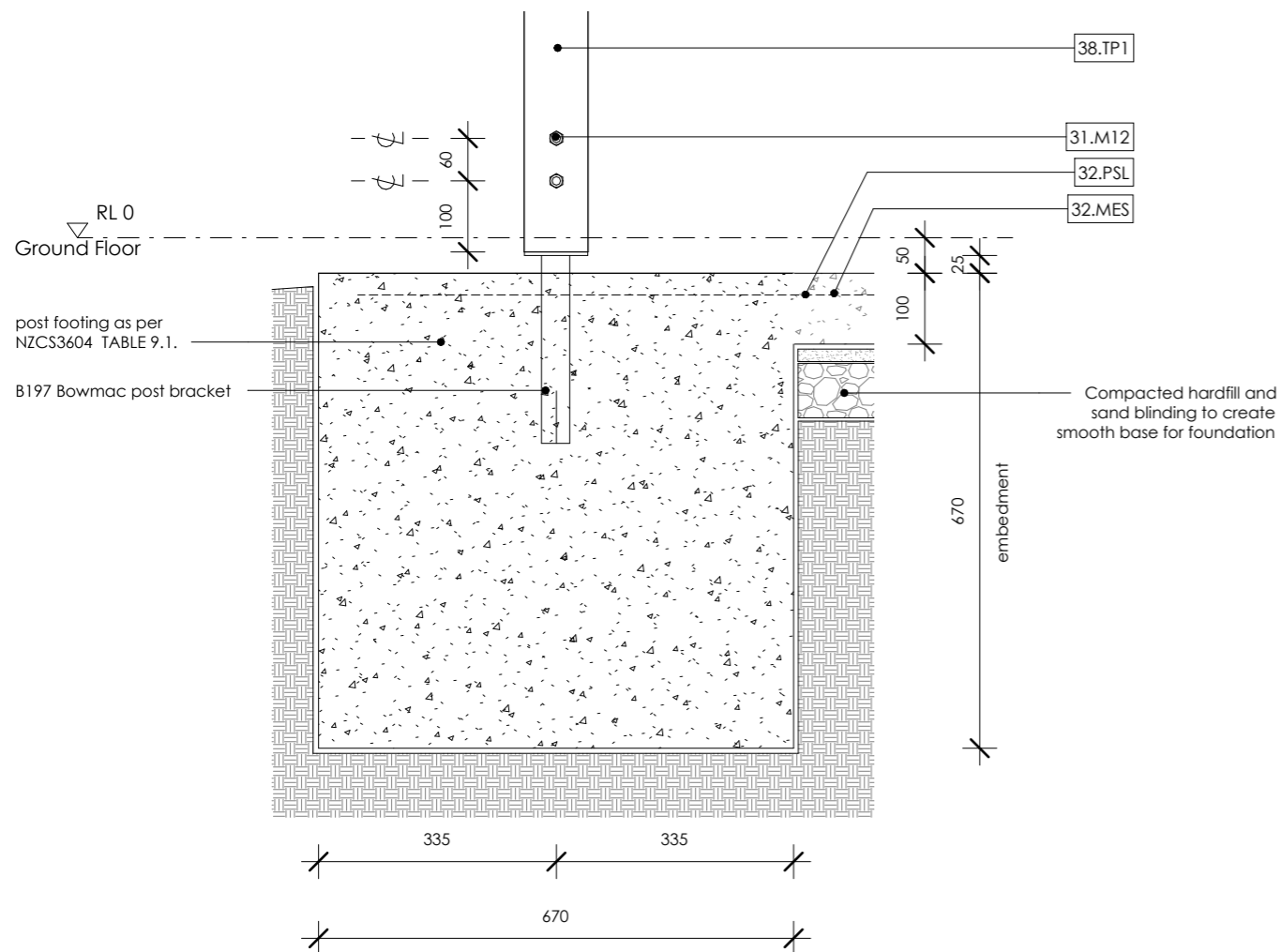

101 Post detail 1

A2.60 1 : 10 @ A3

102 Post detail 2

A2.60 1 : 10 @ A3

Keynote Legend Per Page

Key Value	Keynote Text
31.FAS	12mm hdg cast-in anchor + 50x50x3mm galvanized washer@ max. 900ctrs - 66mm min. from concrete edge. Position a 'Fixing Anchor' within 150mm of the end of each plate or any wall bracing element.
31.RDN	65x2.8mm Round Drive ring shank nails for batten fixing
31.WBE	WATERBAR: Waterbar epoxied into sawcut.
32.A10	R10 @ 600ctrs vertically
32.BAR	BAR: 2/D12 Bar horizontal.
32.COS	Waterproof concrete when dry with concrete sealer.
32.FSE	FOOTING: Concrete footing 200mm wide down to good ground. 140mm width, 150mm height nib with scabble to slab, d10 starters @ 600ctrs, D10 running length of nib.
32.MES	MESH: 500E grade mesh with 30mm min. top cover.
32.REB	REBAR: D12 rebar @400ctrs.50mm below slab surface to clear reinforcing. lap 400 within slab mesh. 150mm epoxy-fixed into existing slab.

Keynote Legend Per Page

Key Value	Keynote Text
32.SLB	SLAB ON GROUND: 100mm thick 20mpa concrete slab reinforced with SE62 500E grade mesh over 250 micron polythene DPM.
38.ETF1	EXTERNAL TIMBER FRAMING: 140 x 45mm, H1.2 studs at 600mm centres max.
42.AXO	AXON Panel: 9mm thick x 1200mm wide Axon Panel, over CLD cavity battens fixed to wall framing, over RAB board to new timber wall framing. To be installed in accordance with Axon Panel Technical Specification. Coat paint finish to match existing cladding, unless noted otherwise.
42.CCL	CAVITY CLOSER: Cavity closure strip Hardie uPVC vent strip 75mm min upstand with 1000mm2 of opening per lineal metre. Keep clear of debris.
42.SCB	CAVITY BATTEN: 70 x 19mm Hardie CLD Structural Cavity Batten installed in 20mm drained cavity fixing.
47.RAB	Rigid Air Barrier: James Hardie RAB Board 6mm.
47.SNF	SEAL: apply continuous 6mm bead of Seal n Flex-1 or Sikaflex 11FC adhesive sealant.
51.HGL	13mm GIB Standard interior wall lining, level 4 plaster and paint finish
52.TPI	PACKER: Timber packer over DPC.

General Notes:

1. This drawing shall be read in conjunction with all other drawings & specifications.
2. All work shall be strictly in accordance with the New Zealand Building Code, Local Territorial Authority Requirements, OSH Requirements & Regulations, and any other Statutory Requirements that may be applicable to this project.
3. All work shall be of best trade practice.
4. Do not scale from this drawing. Use only figured dimensions. The Contractor shall verify all dimensions on site, and report any discrepancies to the Architect before commencing work.

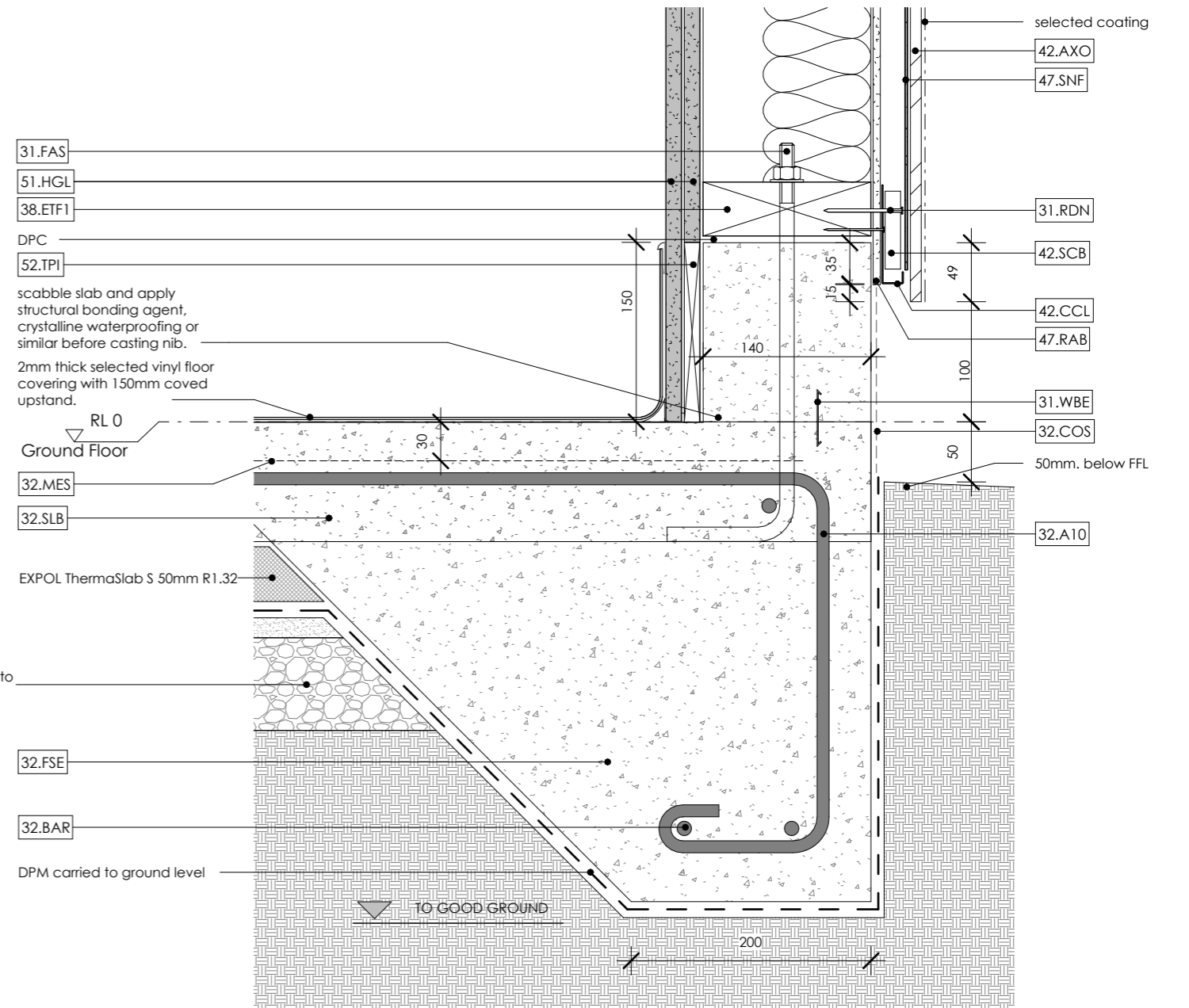
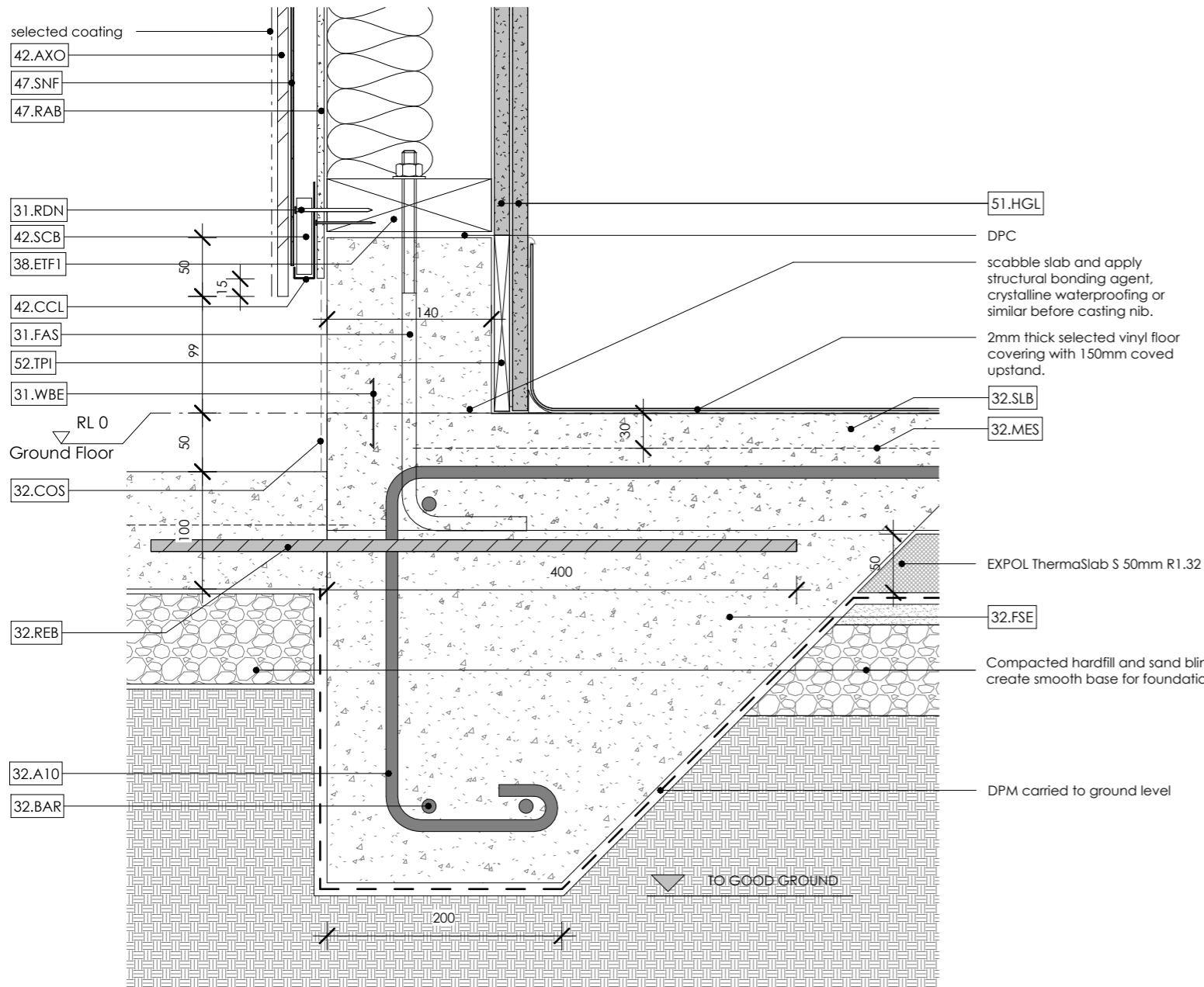

201 Foundation detail connect with exterior slab

A2.60 1 : 5 @ A3

202 Foundation detail

A2.60 1 : 5 @ A3



Copyright:
The copyright of this drawings remains the property of DLA Architects Limited and may only be used or re-used with DLA's prior written consent.

Project:
Clandeboye Bio Mass Control Room & Amenities

Client:
Fonterra Clandeboye

Drawing Title:
Foundation Join With Wall Detail
CAD File:

REV.	DATE	REVISION DETAILS
1	28/08/24	Tender Issue
0	27/05/24	First Issue

Scale: 1 : 5 @ A3	Date: 29/08/24	Drawn: MX
Job No: C919	Designed: MA	Checked: CG
Drawing No: A8.01	Revision No: 1	

- General Notes:**
1. This drawing shall be read in conjunction with all other drawings & specifications.
 2. All work shall be strictly in accordance with the New Zealand Building Code, Local Territorial Authority Requirements, OSH Requirements & Regulations, and any other Statutory Requirements that may be applicable to this project.
 3. All work shall be of best trade practice.
 4. Do not scale from this drawing. Use only figured dimensions. The Contractor shall verify all dimensions on site, and report any discrepancies to the Architect before commencing work.

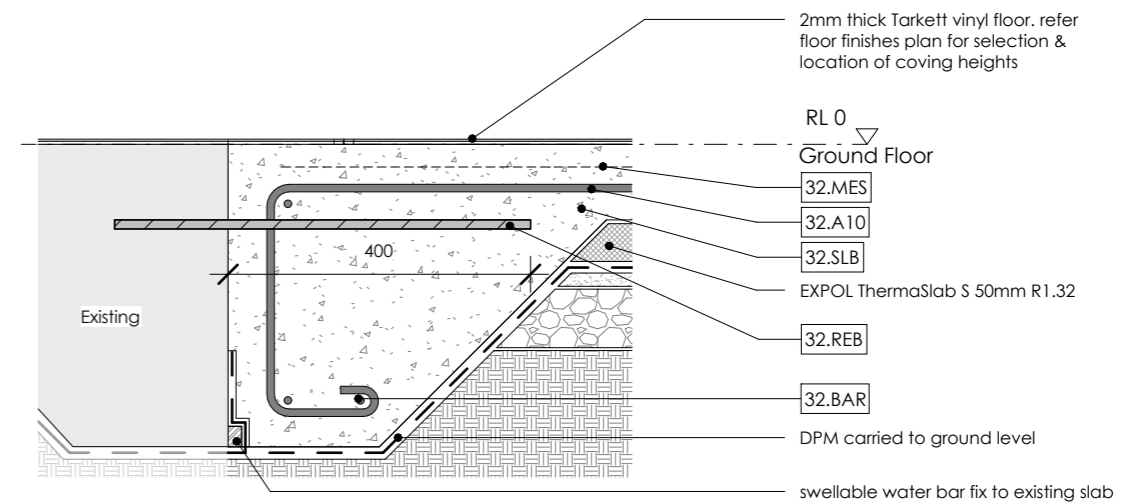
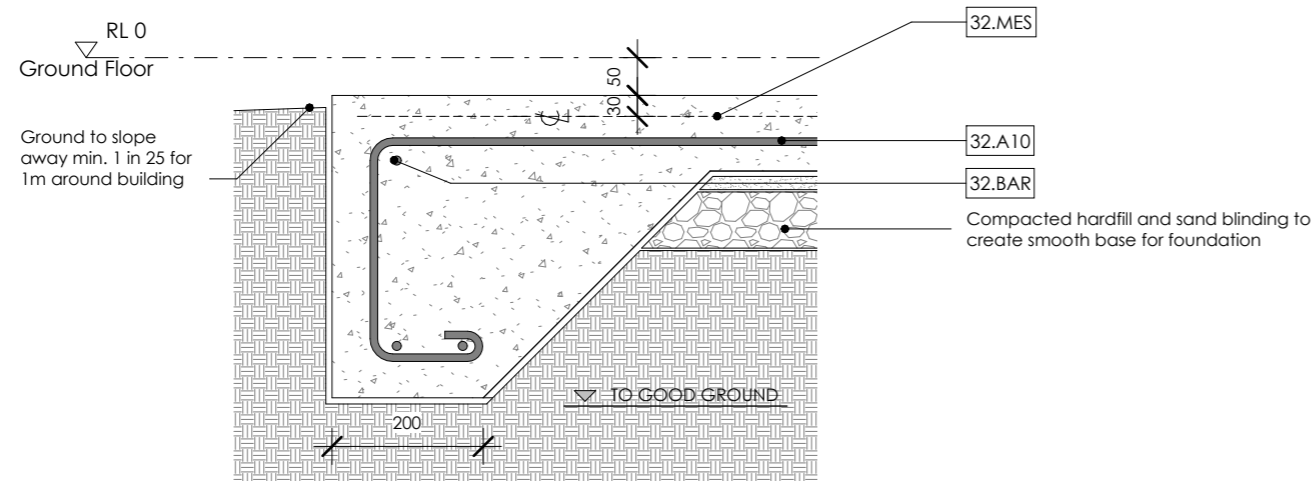

1 Exterior foundation detail
A2.60 1 : 10 @ A3

2 Foundation joint no nib
A2.60 1 : 10 @ A3

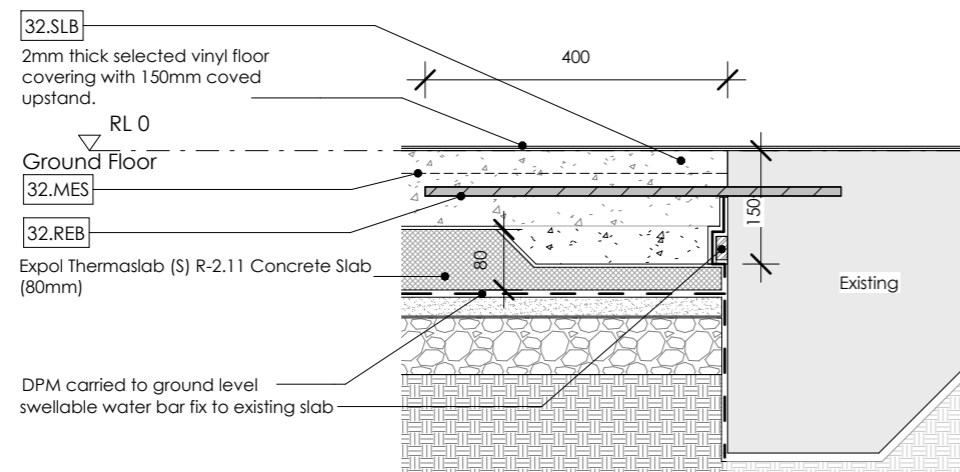

Keynote Legend Per Page	
Key Value	Keynote Text
32.A10	R10 @ 600ctrs vertically
32.BAR	BAR: 2/D12 Bar horizontal.
32.MES	MESH: 500E grade mesh with 30mm min. top cover.
32.REB	REBAR: D12 rebar @400ctrs.50mm below slab surface to clear reinforcing. lap 400 within slab mesh. 150mm epoxy-fixed into existing slab.
32.SLB	SLAB ON GROUND: 100mm thick 20mpa concrete slab reinforced with SE62 500E grade mesh over 250 micron polythene DPM.

3 Foundation joint with existing
A2.61 1 : 10 @ A3

General Notes:

1. This drawing shall be read in conjunction with all other drawings & specifications.
2. All work shall be strictly in accordance with the New Zealand Building Code, Local Territorial Authority Requirements, OSH Requirements & Regulations, and any other Statutory Requirements that may be applicable to this project.
3. All work shall be of best trade practice.
4. Do not scale from this drawing. Use only figured dimensions. The Contractor shall verify all dimensions on site, and report any discrepancies to the Architect before commencing work.

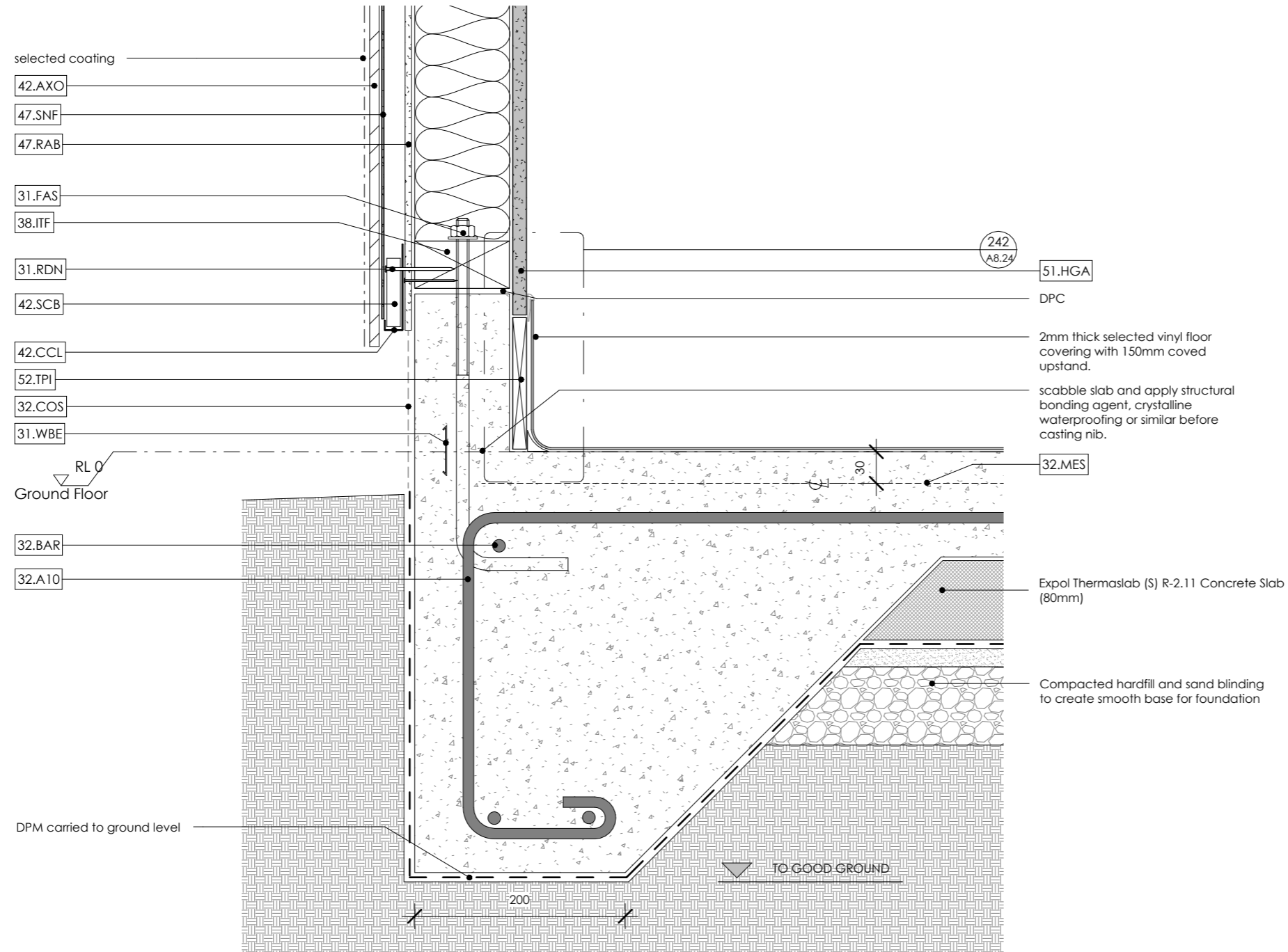

Keynote Legend Per Page

Key Value	Keynote Text
31.FAS	12mm hdg cast-in anchor + 50x50x3mm galvanized washer@ max. 900ctrs - 66mm min. from concrete edge. Position a 'Fixing Anchor' within 150mm of the end of each plate or any wall bracing element.
31.RDN	65x2.8mm Round Drive ring shank nails for batten fixing
31.WBE	WATERBAR: Waterbar epoxied into sawcut.
32.A10	R10 @ 600ctrs vertically
32.BAR	BAR: 2/D12 Bar horizontal.
32.COS	Waterproof concrete when dry with concrete sealer.
32.MES	MESH: 500E grade mesh with 30mm min. top cover.
38.ITF	INTERNAL TIMBER FRAMING: Construct with 90mm x 45mm SG8 h1.2 framing with studs @ 600mm crs to nzs3604:2011. Dwang for all fittings, fixtures, linings, bracing panels & trims. DPC between bottom plate and conc. Slab.
42.AXO	AXON Panel: 9mm thick x 1200mm wide Axon Panel, over CLD cavity battens fixed to wall framing, over RAB board to new timber wall framing. To be installed in accordance with Axon Panel Technical Specification. Coat point finish to match existing cladding, unless noted otherwise.
42.CCL	CAVITY CLOSER: Cavity closure strip Hardie uPVC vent strip 75mm min upstand with 1000mm ² of opening per lineal metre. Keep clear of debris.
42.SCB	CAVITY BATTEN: 70 x 19mm Hardie CLD Structural Cavity Batten installed in 20mm drained cavity fixing.
47.RAB	Rigid Air Barrier: James Hardie RAB Board 6mm.
47.SNF	SEAL: apply continuous 6mm bead of Seal n Flex-1 or Sikaflex 11FC adhesive sealant.
51.HGA	13mm GIB Aqualine interior wall lining, level 4 plaster and paint finish
52.TPI	PACKER: Timber packer over DPC.

301 Foundation Detail 90mm Nib

A2.61 1 : 5 @ A3

General Notes:

1. This drawing shall be read in conjunction with all other drawings & specifications.
2. All work shall be strictly in accordance with the New Zealand Building Code, Local Territorial Authority Requirements, OSH Requirements & Regulations, and any other Statutory Requirements that may be applicable to this project.
3. All work shall be of best trade practice.
4. Do not scale from this drawing. Use only figured dimensions. The Contractor shall verify all dimensions on site, and report any discrepancies to the Architect before commencing work.

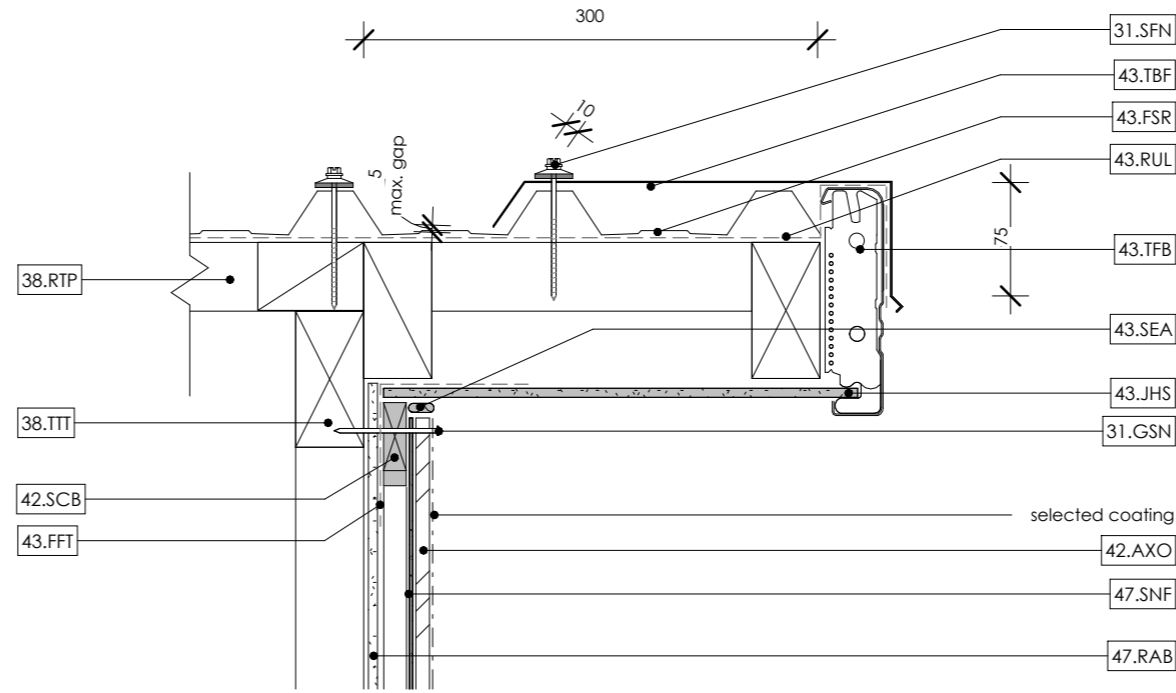
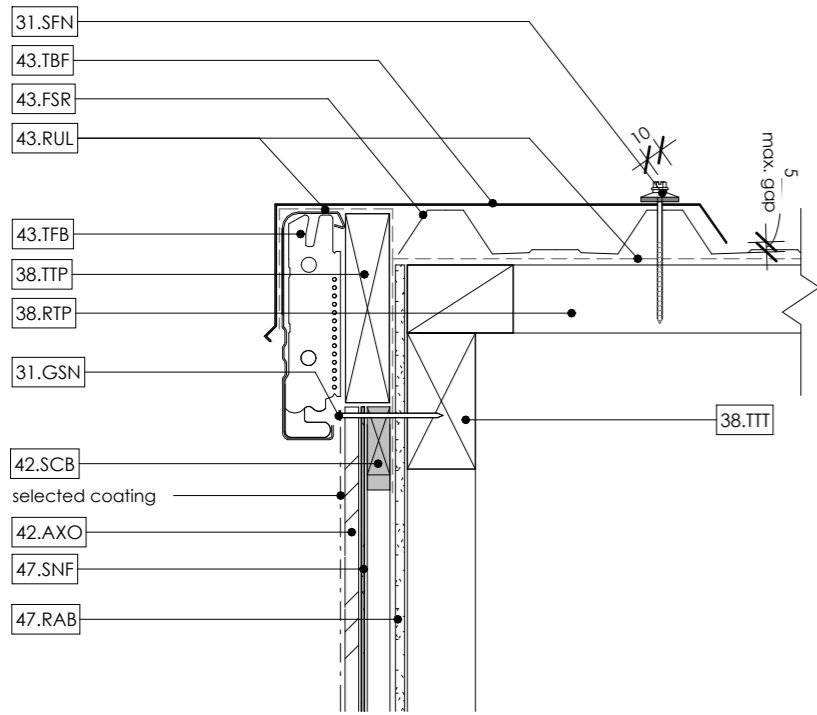

401 Barge Flashing no eaves

A4.01 1 : 5 @ A3

402 Barge Flashing Overhang

A4.01 1 : 5 @ A3

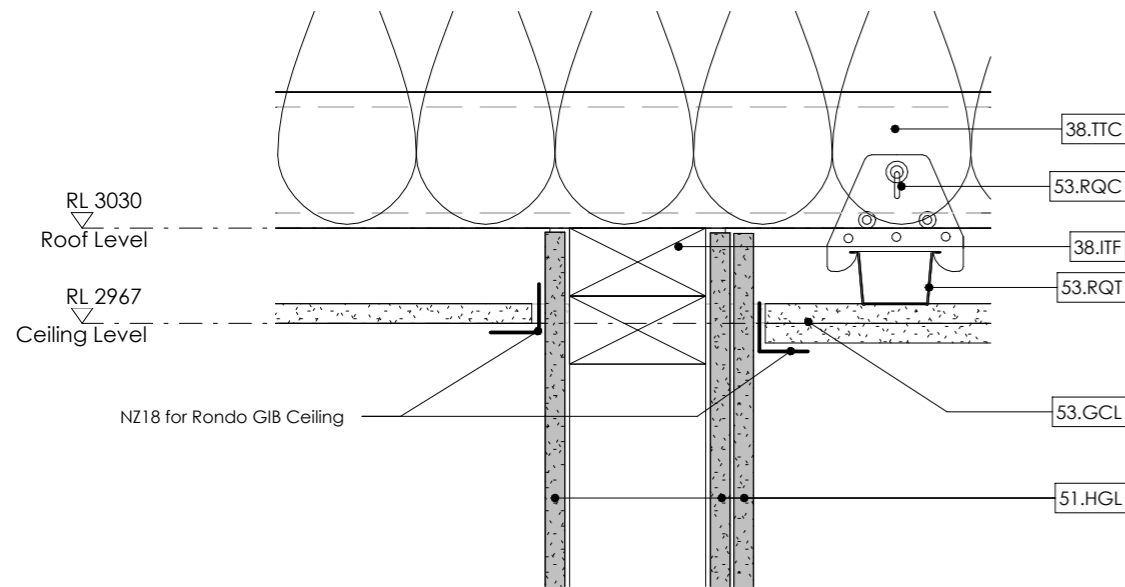

403 Interior ceiling detail

A5.00 1 : 5 @ A3

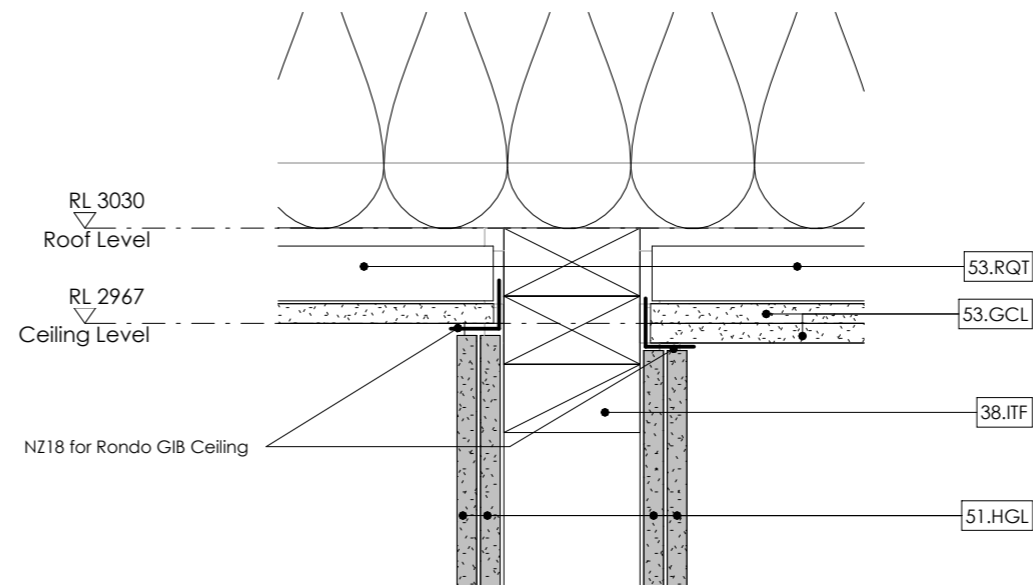

404 Interior ceiling detail with double GIB

A5.01 1 : 5 @ A3

Keynote Legend Per Page

Key Value	Keynote Text
31.GSN	NAIL: galvanized steel nail.
31.SFN	SCREW: min. 12 gauge screw fixing w/ neoprene washer over EPDM washer where required to allow for expansion. 613 - Hit 2, Miss 2, Hit 1. 75mm nail.
38.ITF	INTERNAL TIMBER FRAMING: Construct with 90mm x 45mm SG8 h1.2 framing with studs @ 600mm crs to nzs3604:2011. Dwang at 800mm crs. Dwang for all fittings, fixtures, linings, bracing panels & trims. DPC between bottom plate and conc. Slab.
38.RTP	TIMBER PURLINS: 70x45mm SG8 H1.2 treated timber purlins with 900mm spacing, max fixed with 1/10g Self-drilling screw, 80mm long, at each rafter/truss.
38.TTC	TIMBER TRUSS CONSTRUCTION: Timber trusses @ 900 crs generally designed, fabricated and fixed according to the engineered truss design and specifications.
38.TTP	TIMBER PACKER.
38.TTT	TIMBER TRUSS: timber end truss to take cladding.
42.AXO	AXON Panel: 9mm thick x 1200mm wide Axon Panel, over CLD cavity battens fixed to wall framing, over RAB board to new timber wall framing. To be installed in accordance with Axon Panel Technical Specification. Coat paint finish to match existing cladding, unless noted otherwise.
42.SCB	CAVITY BATTEN: 70 x 19mm Hardie CLD Structural Cavity Batten installed in 20mm drained cavity fixing.
43.FFT	ROOF FLASHING: flexible flashing tape to seal off roof space from cladding cavity.
43.FSR	ROOFING: Freeman Six Rib Roofing 0.55 BMT Colorcote MagnaFlow pre-finished steel trapezoidal roofing. Colour match the existing.
43.JHS	JAMES HARDIE SOFFIT LINING: 6mm prefinished Villaboard Eaves soffit lining and pvc jointers with painted finish
43.RUL	UNDERLAY: Thermakraft Covertek 407 roof underlay
43.SEA	BRANZ approved flexible sealant.
43.TBF	TYPICAL METAL BARGE FLASHING: 0.55 BMT Colorcote MagnaFlow (matching colour as roof cladding) Barge flashing lapped over roof cladding, lap min. 2 crests.
43.TFB	TYPICAL METAL FASCIA/BARGE BOARD 147mm: 0.55BMT Colorcote MagnaFlow formed steel fascia with clips fixed to framing. Colorcote MagnaFlow gutters packed off fascia with 6mm gap behind.
47.RAB	Rigid Air Barrier: James Hardie RAB Board 6mm.
47.SNF	SEAL: apply continuous 6mm bead of Seal n Flex-1 or Sikaflex 11FC adhesive sealant.
51.HGL	13mm GIB Standard interior wall lining, level 4 plaster and paint finish
53.GCL	GIB BOARD CEILING LINING: 13mm Standary GIB board ceiling lining, level 4 GIB stopping and 3 coat paint finish, supported by rondo suspended ceiling grid system. Refer to Colour Schedule.
53.RQC	RONDO QUIET CLIP fixed to truss bottom chords
53.RQT	Rondo track 310mm.

Keynote Legend Per Page

Key Value	Keynote Text
31.FAS	12mm hdg cast-in anchor + 50x50x3mm galvanized washer@ max. 900ctrs - 66mm min. from concrete edge. Position a 'Fixing Anchor' within 150mm of the end of each plate or any wall bracing element.
31.WBE	WATERBAR: Waterbar epoxied into sawcut.
32.A10	R10 @ 600ctrs vertically
32.BAR	BAR: 2/D12 Bar horizontal.
32.FSE	FOOTING: Concrete footing 200mm wide down to good ground. 140mm width, 150mm height nib with scabble to slab, d10 starters @ 600crs, D10 running length of nib.
32.MES	MESH: 500E grade mesh with 30mm min. top cover.
32.REB	REBAR: D12 rebar @400crs.50mm below slab surface to clear reinforcing. lap 400 within slab mesh. 150mm epoxy-fixed into existing slab.
32.SLB	SLAB ON GROUND: 100mm thick 20mpa concrete slab reinforced with SE62 500E grade mesh over 250 micron polythene DPM.
38.ETE	EXTERNAL TIMBER FRAMING EXISTING: 90 x 45mm, H1.2 treated timber wall framing remain unchanged.
38.ETF1	EXTERNAL TIMBER FRAMING: 140 x 45mm, H1.2 studs at 600mm centres max.
43.DPC	DPC to provide separation of metal capping and timber.
51.HGL	13mm GIB Standard interior wall lining, level 4 plaster and paint finish
52.TPI	PACKER: Timber packer over DPC.

General Notes:

1. This drawing shall be read in conjunction with all other drawings & specifications.
2. All work shall be strictly in accordance with the New Zealand Building Code, Local Territorial Authority Requirements, OSH Requirements & Regulations, and any other Statutory Requirements that may be applicable to this project.
3. All work shall be of best trade practice.
4. Do not scale from this drawing. Use only figured dimensions. The Contractor shall verify all dimensions on site, and report any discrepancies to the Architect before commencing work.

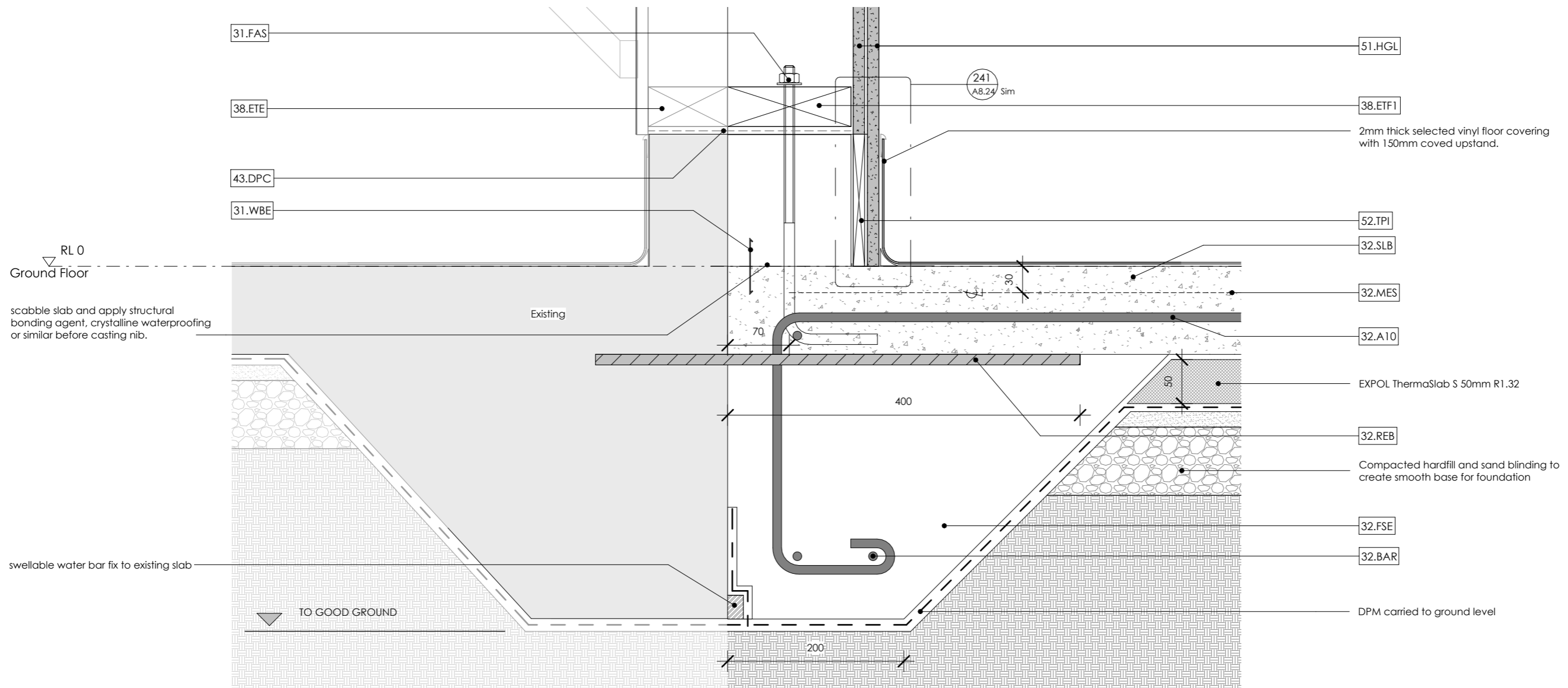

1

Foundation connect with existing

A2.60

1 : 5 @ A3



timaru.
t: +64 3 683 1300
e: admin@dla.co.nz
49 george street,
timaru, 7910

Copyright:
The copyright of this drawings remains the property of DLA Architects Limited and may only be used or re-used with DLA's prior written consent.

Project:
Clandeboyne Bio Mass Control Room & Amenities

Client:
Fonterra Clandeboyne

Drawing Title:
Foundation and nib connect with existing
CAD File:

REV.	DATE	REVISION DETAILS
1	28/08/24	Tender Issue
0	27/05/24	First Issue

Scale: 1 : 5 @ A3	Date: 29/08/24	Drawn: MX
Job No: C919	Designed: MA	Checked: CG
Drawing No: A8.05	Revision No: 1	

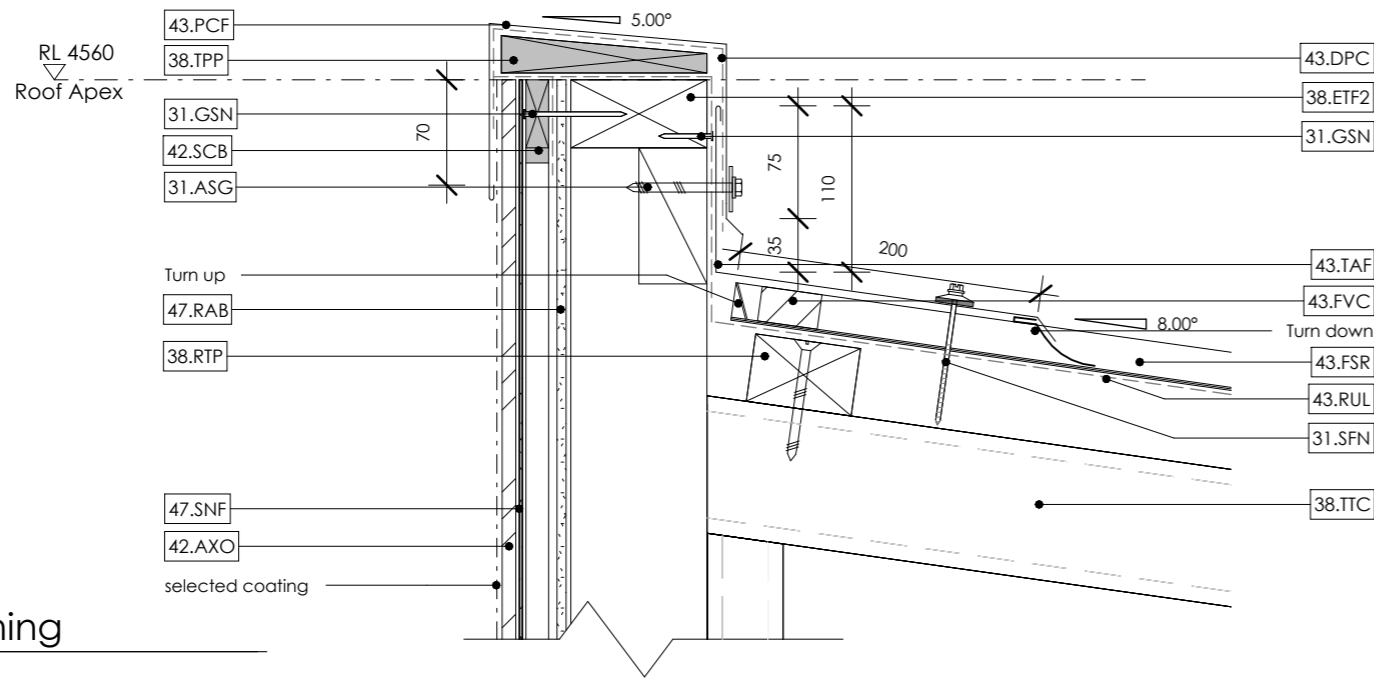

- General Notes:**
1. This drawing shall be read in conjunction with all other drawings & specifications.
 2. All work shall be strictly in accordance with the New Zealand Building Code, Local Territorial Authority Requirements, OSH Requirements & Regulations, and any other Statutory Requirements that may be applicable to this project.
 3. All work shall be of best trade practice.
 4. Do not scale from this drawing. Use only figured dimensions. The Contractor shall verify all dimensions on site, and report any discrepancies to the Architect before commencing work.

501 Cap Flashing
A4.00 1 : 5 @ A3

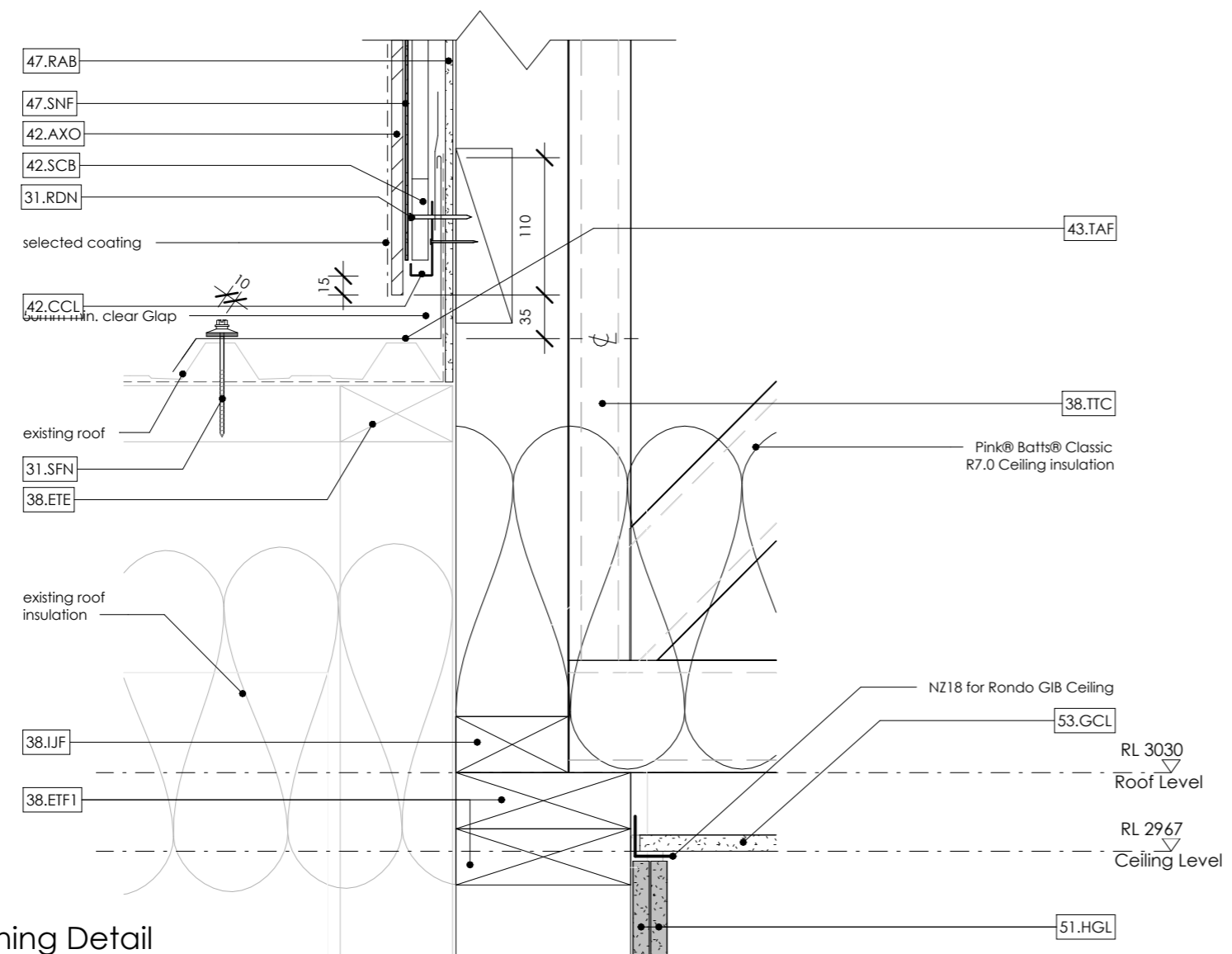

502 Apron Flashing Detail
A4.00 1 : 5 @ A3

Keynote Legend Per Page	
Key Value	Keynote Text
31.ASG	ANCHOR SCREW: anchor screw M6 30x30x3mm galvanized washer.
31.GSN	NAIL: galvanized steel nail.
31.RDN	65x2.8mm Round Drive ring shank nails for batten fixing
31.SFN	SCREW: min. 12 gauge screw fixing w/ neoprene washer over EPDM washer where required to allow for expansion. 6T3 - Hit 2, Miss 2, Hit 1. 75mm nail.
38.ETE	EXTERNAL TIMBER FRAMING EXISTING: 90 x 45mm, H1.2 treated timber wall framing remain unchanged.
38.ETF1	EXTERNAL TIMBER FRAMING: 140 x 45mm, H1.2 studs at 600mm centres max.
38.ETF2	EXTERNAL TIMBER FRAMING: Construct with 90 x 45mm, H1.2 studs at 600mm centres max.
38.IJF	Jack framing. 90 x 45 @ 600 crs. dwangs 800crs max.
38.RTP	TIMBER PURLINS: 70x45mm SG8 H1.2 treated timber purlins with 900mm spacing, max fixed with 1/10g Self-drilling screw, 80mm long, at each rafter/truss.
38.TPP	TIMBER PACKER PITCH: H3.2 timber packer shaped to suit 5deg. pitch.
38.TTC	TIMBER TRUSS CONSTRUCTION: Timber trusses @ 900 crs generally designed, fabricated and fixed according to the engineered truss design and specifications.
42.AXO	AXON Panel: 9mm thick x 1200mm wide Axon Panel, over CLD cavity battens fixed to wall framing, over RAB board to new timber wall framing. To be installed in accordance with Axon Panel Technical Specification. Coat paint finish to match existing cladding, unless noted otherwise.
42.CCL	CAVITY CLOSER: Cavity closure strip Hardie uPVC vent strip 75mm min upstand with 1000mm2 of opening per lineal metre. Keep clear of debris.
42.SCB	CAVITY BATTEN: 70 x 19mm Hardie CLD Structural Cavity Batten installed in 20mm drained cavity fixing.
43.DPC	DPC to provide separation of metal capping and timber.
43.FSR	ROOFING: Freeman Six Rib Roofing 0.55 BMT Colorcote MagnaFlow pre-finished steel trapezoidal roofing. Colour match the existing.
43.FVC	foam vented cavity closure strip.
43.PCF	CAP FLASHING: 0.55BMT Colorcote MagnaFlow pre-finished parapet cap flashing
43.RUL	UNDERLAY: Thermakraft Covertek 407 roof underlay
43.TAF	TYPICAL APRON FLASHING: 0.55mm BMT Colorcote MagnaFlow apron flashings complete with hem. 75mm min. cover to over flashing, 110mm total height. over flashing w/ 35mm min. clearance to apron flashing. refer to cladding notes for material type.
47.RAB	Rigid Air Barrier: James Hardie RAB Board 6mm.
47.SNF	SEAL: apply continuous 6mm bead of Seal n Flex-1 or Sikaflex 11FC adhesive sealant.
51.HGL	13mm GIB Standard interior wall lining, level 4 plaster and paint finish
53.GCL	GIB BOARD CEILING LINING: 13mm Standary GIB board ceiling lining, level 4 GIB stopping and 3 coat paint finish, supported by rondo suspended ceiling grid system. Refer to Colour Schedule.



Copyright:
The copyright of this drawings remains the property of DLA Architects Limited and may only be used or re-used with DLA's prior written consent.

Project:
Clandeboy Bio Mass Control Room & Amenities

Client:
Fonterra Clandeboy

Drawing Title:
Cap & Apron Flashing Detail
CAD File:

REV.	DATE	REVISION DETAILS
1	28/08/24	Tender Issue
0	27/05/24	First Issue

Scale: 1 : 5 @ A3	Date: 29/08/24	Drawn: MX
Job No: C919	Designed: MA	Checked: CG
Drawing No: A8.06	Revision No: 1	

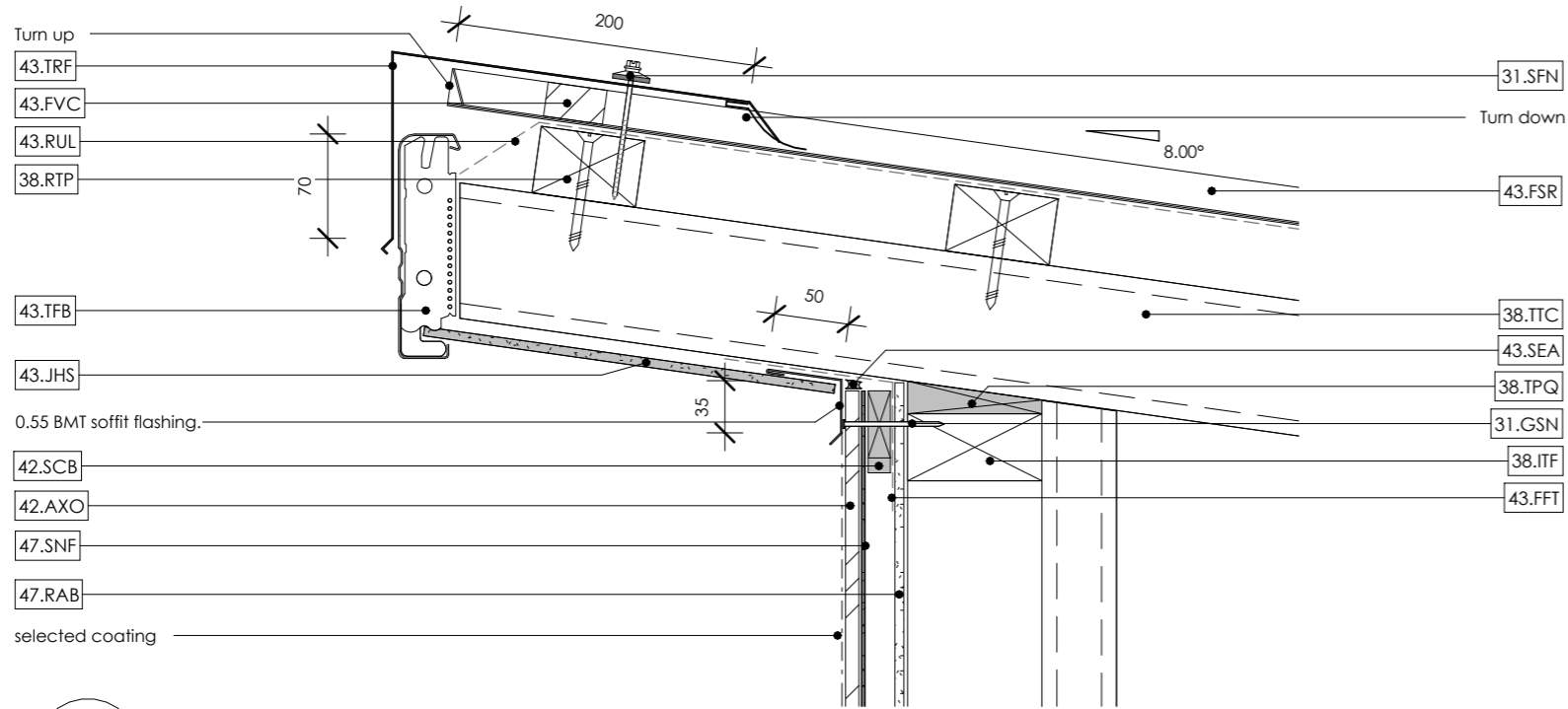

601 Cap flashing with eaves
A4.00 1 : 5 @ A3

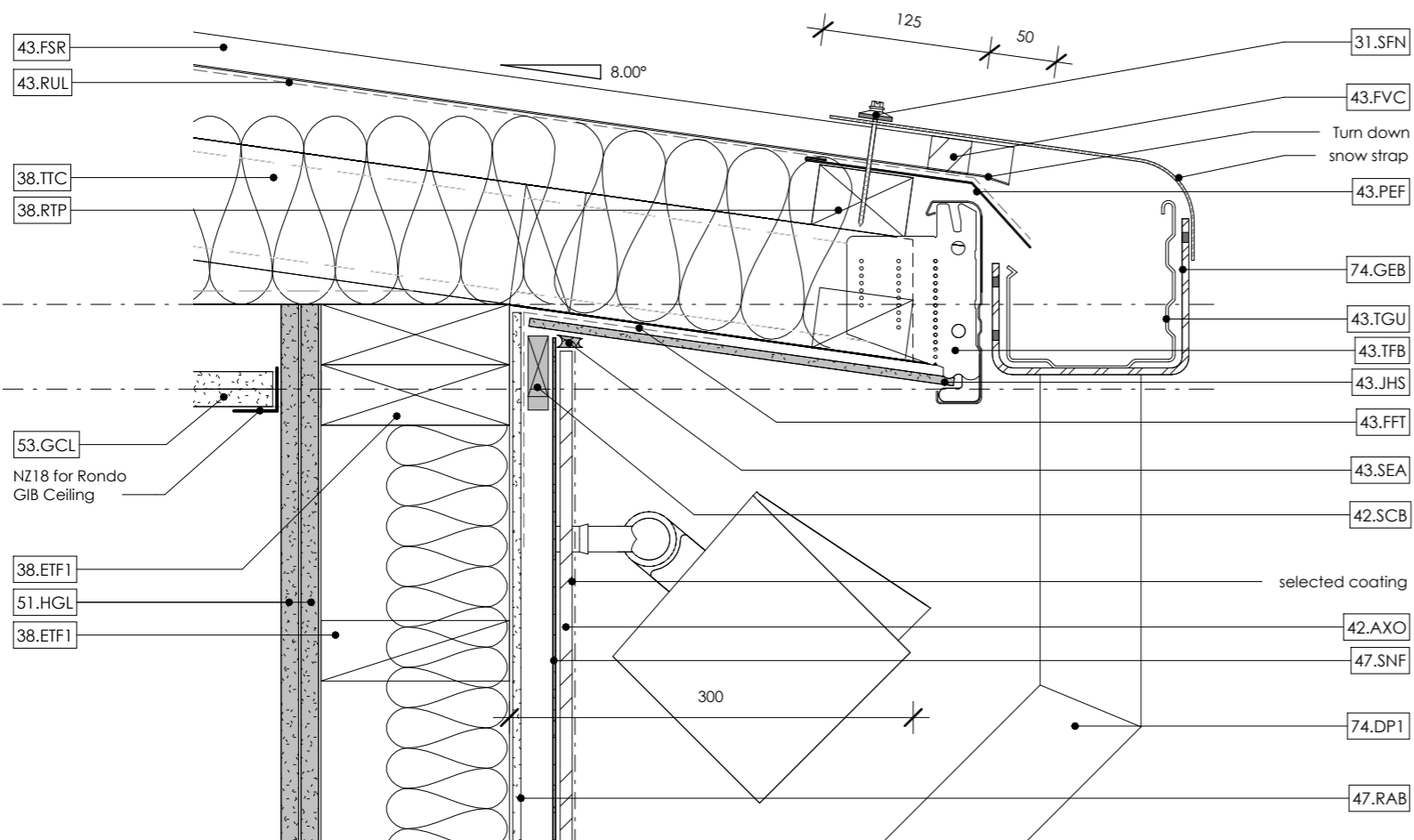

602 Gutter detail
A4.00 1 : 5 @ A3

- General Notes:**
1. This drawing shall be read in conjunction with all other drawings & specifications.
 2. All work shall be strictly in accordance with the New Zealand Building Code, Local Territorial Authority Requirements, OSH Requirements & Regulations, and any other Statutory Requirements that may be applicable to this project.
 3. All work shall be of best trade practice.
 4. Do not scale from this drawing. Use only figured dimensions. The Contractor shall verify all dimensions on site, and report any discrepancies to the Architect before commencing work.

Keynote Legend Per Page	
Key Value	Keynote Text
31.GSN	NAIL: galvanized steel nail.
31.SFN	SCREW: min. 12 gauge screw fixing w/ neoprene washer over EPDM washer where required to allow for expansion. 6T3 - Hit 2, Miss 2, Hit 1. 75mm nail.
38.ETF1	EXTERNAL TIMBER FRAMING: 140 x 45mm, H1.2 studs at 600mm centres max.
38.ITF	INTERNAL TIMBER FRAMING: Construct with 90mm x 45mm SG8 h1.2 framing with studs @ 600mm crs to nzs3604:2011. Dwang at 800mm crs. Dwang for all fittings, fixtures, linings, bracing panels & trims. DPC between bottom plate and conc. Slab.
38.RTP	TIMBER PURLINS: 70x45mm SG8 H1.2 treated timber purlins with 900mm spacing, max fixed with 1/10g Self-drilling screw, 80mm long, at each rafter/truss.
38.TPQ	TIMBER PACKER PITCH: H1.2 timber packer shaped to suit 8deg. pitch.
38.TTC	TIMBER TRUSS CONSTRUCTION: Timber trusses @ 900 crs generally designed, fabricated and fixed according to the engineered truss design and specifications.
42.AXO	AXON Panel: 9mm thick x 1200mm wide Axon Panel, over CLD cavity battens fixed to wall framing, over RAB board to new timber wall framing. To be installed in accordance with Axon Panel Technical Specification. Coat paint finish to match existing cladding, unless noted otherwise.
42.SCB	CAVITY BATTEN: 70 x 19mm Hardie CLD Structural Cavity Batten installed in 20mm drained cavity fixing.
43.FFT	ROOF FLASHING: flexible flashing tape to seal off roof space from cladding cavity.
43.FSR	ROOFING: Freeman Six Rib Roofing 0.55 BMT Colorcote MagnaFlow pre-finished steel trapezoidal roofing. Colour match the existing.
43.FVC	foam vented cavity closure strip.
43.JHS	JAMES HARDIE SOFFIT LINING: 6mm prefinished Villaboard Eaves soffit lining and pvc jointers with painted finish
43.PEF	EAVE FLASHING: 0.55 BMT pre-finished eave flashing.
43.RUL	UNDERLAY: Thermakraft Covertex 407 roof underlay
43.SEA	BRANZ approved flexible sealant.
43.TFB	TYPICAL METAL FASCIA/BARGE BOARD 147mm: 0.55BMT Colorcote MagnaFlow formed steel fascia with clips fixed to framing. Colorcote MagnaFlow gutters packed off fascia with 6mm gap behind.
43.TGU	TYPICAL GUTTER: Colorcote MagnaFlow steel 125mm Box gutter with external brackets and snow straps @ 500crs fixed in accordance with manufacturers recommendations and colour matched to roofing.
43.TRF	TYPICAL RIDGE FLASHING: 0.55mm BMT Colorcote MagnaFlow ridge flashings complete with control/slip joint.
47.RAB	Rigid Air Barrier: James Hardie RAB Board 6mm.
47.SNF	SEAL: apply continuous 6mm bead of Seal n Flex-1 or Sikaflex 11FC adhesive sealant.
51.HGL	13mm GIB Standard interior wall lining, level 4 plaster and paint finish
53.GCL	GIB BOARD CEILING LINING: 13mm Standary GIB board ceiling lining, level 4 GIB stopping and 3 coat paint finish, supported by rondo suspended ceiling grid system. Refer to Colour Schedule.
74.DP1	DOWNPIPES: 80dia. Colorcote MagnaFlow downpipes with pipe brackets @ 1200crs and maintenance gap to riser with leaf grate
74.GEB	BRACKET: External Gutter bracket spacings 750mm.



Copyright:
The copyright of this drawings remains the property of DLA Architects Limited and may only be used or re-used with DLA's prior written consent.

Project:
Clandeboy Bio Mass Control Room & Amenities

Client:
Fonterra Clandeboy

Drawing Title:
Roof With Eaves
CAD File:

REV.	DATE	REVISION DETAILS
1	28/08/24	Tender Issue
0	27/05/24	First Issue

Scale: 1 : 5 @ A3	Date: 29/08/24	Drawn: MX
Job No: C919	Designed: MA	Checked: CG
Drawing No: A8.07	Revision No: 1	

General Notes:

1. This drawing shall be read in conjunction with all other drawings & specifications.
2. All work shall be strictly in accordance with the New Zealand Building Code, Local Territorial Authority Requirements, OSH Requirements & Regulations, and any other Statutory Requirements that may be applicable to this project.
3. All work shall be of best trade practice.
4. Do not scale from this drawing. Use only figured dimensions. The Contractor shall verify all dimensions on site, and report any discrepancies to the Architect before commencing work.

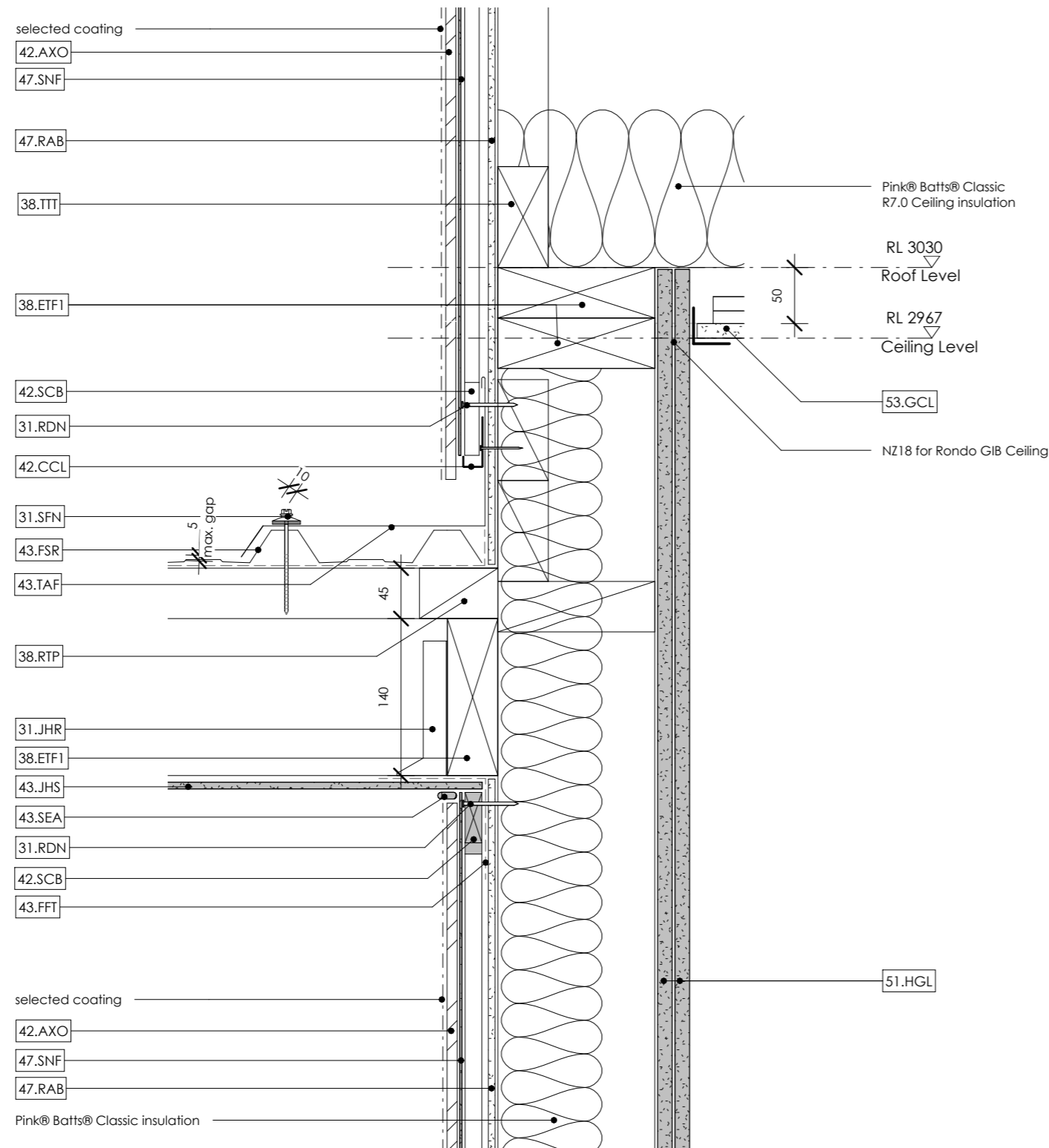

Keynote Legend Per Page

Key Value	Keynote Text
31.JHR	S.S. Lumberlok JH47 x 120 joist hanger. Fix with Product Nails 30mm x 3.15dia. per flange or 2/Type 17-12g x 35mm Hex Head Screws.
31.RDN	65x2.8mm Round Drive ring shank nails for batten fixing
31.SFN	SCREW: min. 12 gauge screw fixing w/ neoprene washer over EPDM washer where required to allow for expansion. 6T3 - Hit 2, Miss 2, Hit 1. 75mm nail.
38.ETF1	EXTERNAL TIMBER FRAMING: 140 x 45mm, H1.2 studs at 600mm centres max.
38.RTP	TIMBER PURLINS: 70x45mm SG8 H1.2 treated timber purlins with 900mm spacing, max fixed with 1/10g Self-drilling screw, 80mm long, at each rafter/truss.
38.TTT	TIMBER TRUSS: timber end truss to take cladding.
42.AXO	AXON Panel: 9mm thick x 1200mm wide Axon Panel, over CLD cavity battens fixed to wall framing, over RAB board to new timber wall framing. To be installed in accordance with Axon Panel Technical Specification. Coat paint finish to match existing cladding, unless noted otherwise.
42.CCL	CAVITY CLOSER: Cavity closure strip Hardie uPVC vent strip 75mm min upstand with 1000mm2 of opening per linear metre. Keep clear of debris.
42.SCB	CAVITY BATTEN: 70 x 19mm Hardie CLD Structural Cavity Batten installed in 20mm drained cavity fixing.
43.FFT	ROOF FLASHING: flexible flashing tape to seal off roof space from cladding cavity.
43.FSR	ROOFING: Freeman Six Rib Roofing 0.55 BMT Colorcote MagnaFlow pre-finished steel trapezoidal roofing. Colour match the existing.
43.JHS	JAMES HARDIE SOFFIT LINING: 6mm prefinished Villaboard Eaves soffit lining and pvc jointers with painted finish
43.SEA	BRANZ approved flexible sealant.
43.TAF	TYPICAL APRON FLASHING: 0.55mm BMT Colorcote MagnaFlow apron flashings complete with hem. 75mm min. cover to over flashing, 110mm total height. over flashing w/ 35mm min. clearance to apron flashing. refer to cladding notes for material type.
47.RAB	Rigid Air Barrier: James Hardie RAB Board 6mm.
47.SNF	SEAL: apply continuous 6mm bead of Seal n Flex-1 or Sikaflex 11FC adhesive sealant.
51.HGL	13mm GIB Standard interior wall lining, level 4 plaster and paint finish
53.GCL	GIB BOARD CEILING LINING: 13mm Standary GIB board ceiling lining, level 4 GIB stopping and 3 coat paint finish, supported by rondo suspended ceiling grid system. Refer to Colour Schedule.

701

Varanda Rafter Join With Wall

A4.01

1 : 5 @ A3

Keynote Legend Per Page	
Key Value	Keynote Text
31.BM12	M12: fix beam with M12 bolts and 50x50x3mm galvanized washer.
31.RDN	65x2.8mm Round Drive ring shank nails for batten fixing
31.SFN	SCREW: min. 12 gauge screw fixing w/ neoprene washer over EPDM washer where required to allow for expansion. 6T3 - Hit 2, Miss 2, Hit 1, 75mm nail.
33.ETF	EXTERNAL TIMBER NOGGING
37.ETB	BEAM: 150 x 45mm timber beam.
37.ETS	STRINGER: 90 x 45mm timber stringer.
37.TBC	BEAD: timber bead cut to suit.
38.ETF1	EXTERNAL TIMBER FRAMING: 140 x 45mm, H1.2 studs at 600mm centres max.
38.RTP	TIMBER PURLINS: 70x45mm SG8 H1.2 treated timber purlins with 900mm spacing, max fixed with 1/10g Self-drilling screw, 80mm long, at each rafter/truss.
38.TTT	TIMBER TRUSS: timber end truss to take cladding.

Keynote Legend Per Page	
Key Value	Keynote Text
42.AXO	AXON Panel: 9mm thick x 1200mm wide Axon Panel, over CLD cavity battens fixed to wall framing, over RAB board to new timber wall framing. To be installed in accordance with Axon Panel Technical Specification. Coat paint finish to match existing cladding, unless noted otherwise.
42.CCL	CAVITY CLOSER: Cavity closure strip Hardie uPVC vent strip 75mm min upstand with 1000mm2 of opening per lineal metre. Keep clear of debris.
42.SCB	CAVITY BATTEN: 70 x 19mm Hardie CLD Structural Cavity Batten installed in 20mm drained cavity fixing.
43.FFT	ROOF FLASHING: flexible flashing tape to seal off roof space from cladding cavity.
43.FSR	ROOFING: Freeman Six Rib Roofing 0.55 BMT Colorcote MagnaFlow pre-finished steel trapezoidal roofing. Colour match the existing.
43.FVC	foam vented cavity closure strip.
43.JHS	JAMES HARDIE SOFFIT LINING: 6mm prefinished Villaboard Eaves soffit lining and pvc jointers with painted finish
43.PEF	EAVE FLASHING: 0.55 BMT pre-finished eave flashing.
43.RUL	UNDERLAY: Thermakraft Covertek 407 roof underlay
43.SEA	BRANZ approved flexible sealant.
43.TAF	TYPICAL APRON FLASHING: 0.55mm BMT Colorcote MagnaFlow apron flashings complete with hem. 75mm min. cover to over flashing, 110mm total height. over flashing w/ 35mm min. clearance to apron flashing. refer to cladding notes for material type.
43.TFB	TYPICAL METAL FASCIA/BARGE BOARD 147mm: 0.55BMT Colorcote MagnaFlow formed steel fascia with clips fixed to framing. Colorcote MagnaFlow gutters packed off fascia with 6mm gap behind.
43.TGU	TYPICAL GUTTER: Colorcote MagnaFlow steel 125mm Box gutter with external brackets and snow straps @ 500crs fixed in accordance with manufacturers recommendations and colour matched to roofing.
47.RAB	Rigid Air Barrier: James Hardie RAB Board 6mm.
47.SNF	SEAL: apply continuous 6mm bead of Seal n Flex-1 or Sikaflex 11FC adhesive sealant.
74.GEB	BRACKET: External Gutter bracket spacings 750mm.

- General Notes:**
1. This drawing shall be read in conjunction with all other drawings & specifications.
 2. All work shall be strictly in accordance with the New Zealand Building Code, Local Territorial Authority Requirements, OSH Requirements & Regulations, and any other Statutory Requirements that may be applicable to this project.
 3. All work shall be of best trade practice.
 4. Do not scale from this drawing. Use only figured dimensions. The Contractor shall verify all dimensions on site, and report any discrepancies to the Architect before commencing work.

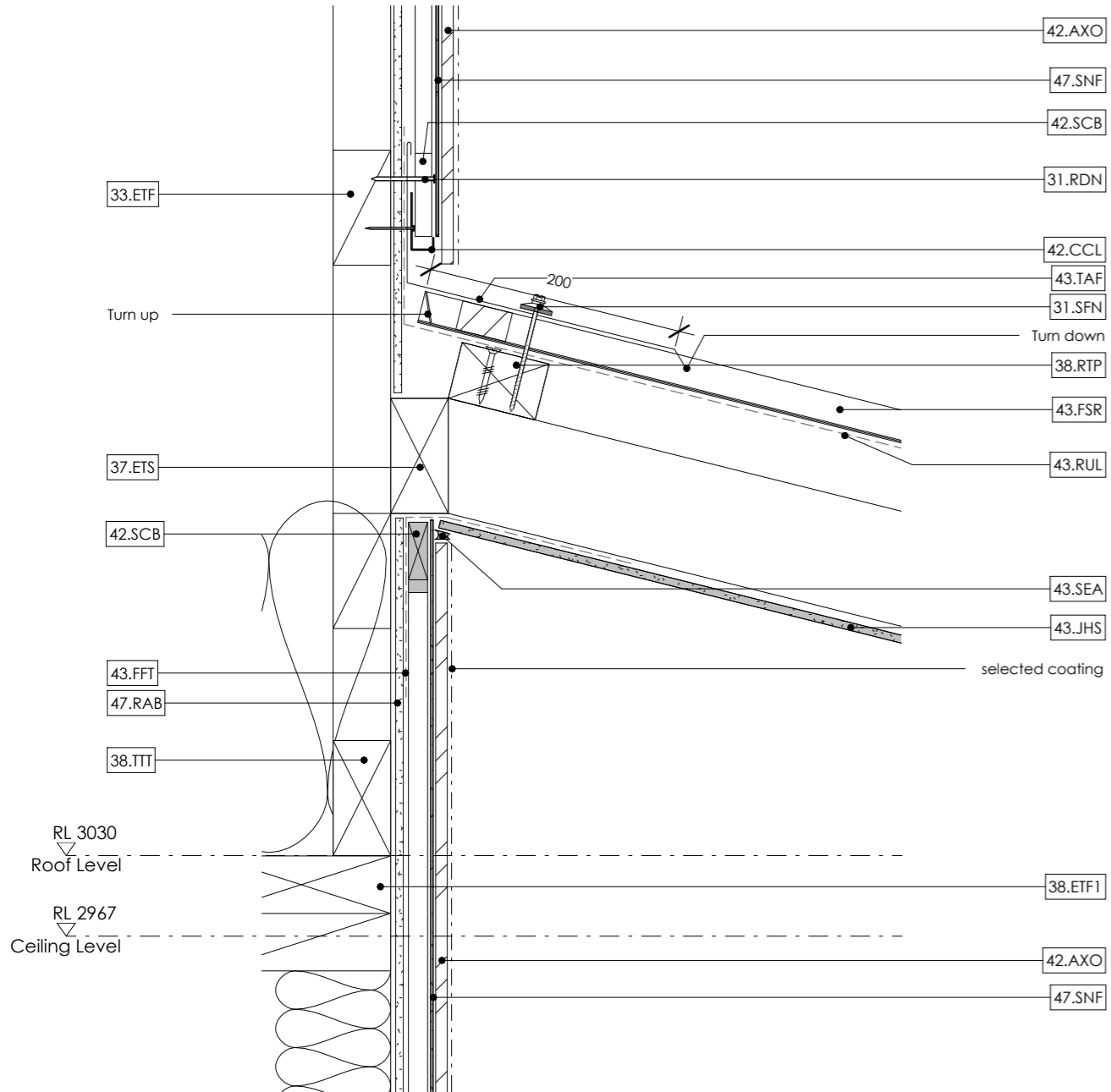

801 Varanda 1 Stringer Detail
A4.00 1 : 5 @ A3

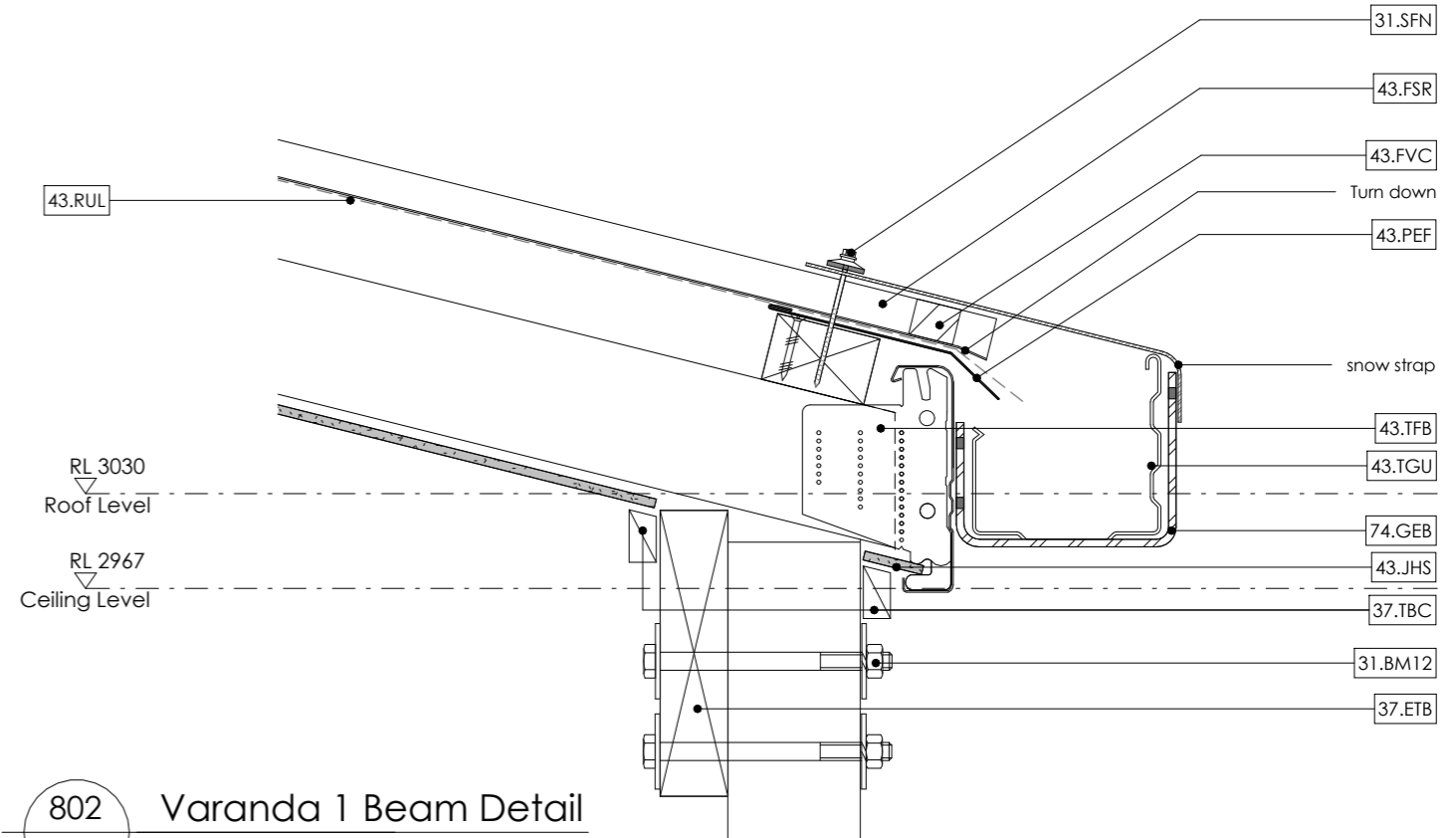

802 Varanda 1 Beam Detail
A4.00 1 : 5 @ A3



Copyright:
The copyright of this drawings remains the property of DLA Architects Limited and may only be used or re-used with DLA's prior written consent.

Project:
Clandeboyce Bio Mass Control Room & Amenities

Client:
Fonterra Clandeboyce

Drawing Title:
Varanda Detail 1
CAD File:

REV.	DATE	REVISION DETAILS
1	28/08/24	Tender Issue
0	27/05/24	First Issue

Scale: 1 : 5 @ A3	Date: 29/08/24	Drawn: MX
Job No: C919	Designed: MA	Checked: CG
Drawing No: A8.09	Revision No: 1	

Keynote Legend Per Page

Key Value	Keynote Text
31.BM12	M12: fix beam with M12 bolts and 50x50x3mm galvanized washer.
31.RDN	65x2.8mm Round Drive ring shank nails for batten fixing
31.SFN	SCREW: min. 12 gauge screw fixing w/ neoprene washer over EPDM washer where required to allow for expansion. 6T3 - Hit 2, Miss 2, Hit 1. 75mm nail.
37.ETB	BEAM: 150 x 45mm timber beam.
37.ETT	STRINGER: 140 x 45mm timber stringer.
37.TBC	BEAD: timber bead cut to suit.
38.ETF1	EXTERNAL TIMBER FRAMING: 140 x 45mm, H1.2 studs at 600mm centres max.
38.ETF2	EXTERNAL TIMBER FRAMING: Construct with 90 x 45mm, H1.2 studs at 600mm centres max.
38.RTP	TIMBER PURLINS: 70x45mm SG8 H1.2 treated timber purlins with 900mm spacing, max fixed with 1/10g Self-drilling screw, 80mm long, at each rafter/truss.
38.TP1	TIMBER POST: Prolam 88x88mm, H5 Visual (PLPH5-100) post with 3 coat paint finish, footing size refer to detail drawing.
38.TTC	TIMBER TRUSS CONSTRUCTION: Timber trusses @ 900 crs generally designed, fabricated and fixed according to the engineered truss design and specifications.
42.AXO	AXON Panel: 9mm thick x 1200mm wide Axon Panel, over CLD cavity battens fixed to wall framing, over RAB board to new timber wall framing. To be installed in accordance with Axon Panel Technical Specification. Coat paint finish to match existing cladding, unless noted otherwise.
42.SCB	CAVITY BATTEN: 70 x 19mm Hardie CLD Structural Cavity Batten installed in 20mm drained cavity fixing.
43.FFT	ROOF FLASHING: flexible flashing tape to seal off roof space from cladding cavity.
43.FSR	ROOFING: Freeman Six Rib Roofing 0.55 BMT Colorcote MagnaFlow pre-finished steel trapezoidal roofing. Colour match the existing.
43.FVC	foam vented cavity closure strip.
43.JHS	JAMES HARDIE SOFFIT LINING: 6mm prefinished Villaboard Eaves soffit lining and pvc jointers with painted finish
43.PEF	EAVE FLASHING: 0.55 BMT pre-finished eave flashing.
43.RUL	UNDERLAY: Thermakraft Covertex 407 roof underlay
43.SEA	BRANZ approved flexible sealant.
43.TAF	TYPICAL APRON FLASHING: 0.55mm BMT Colorcote MagnaFlow apron flashings complete with hem. 75mm min. cover to over flashing, 110mm total height. over flashing w/ 35mm min. clearance to apron flashing. refer to cladding notes for material type.
43.TFA	TYPICAL FASCIA/BARGE BOARD 185mm: 0.55BMT Colorcote MagnaFlow formed steel fascia with clips fixed to framing. Colorcote MagnaFlow gutters packed off fascia with 6mm gap behind.

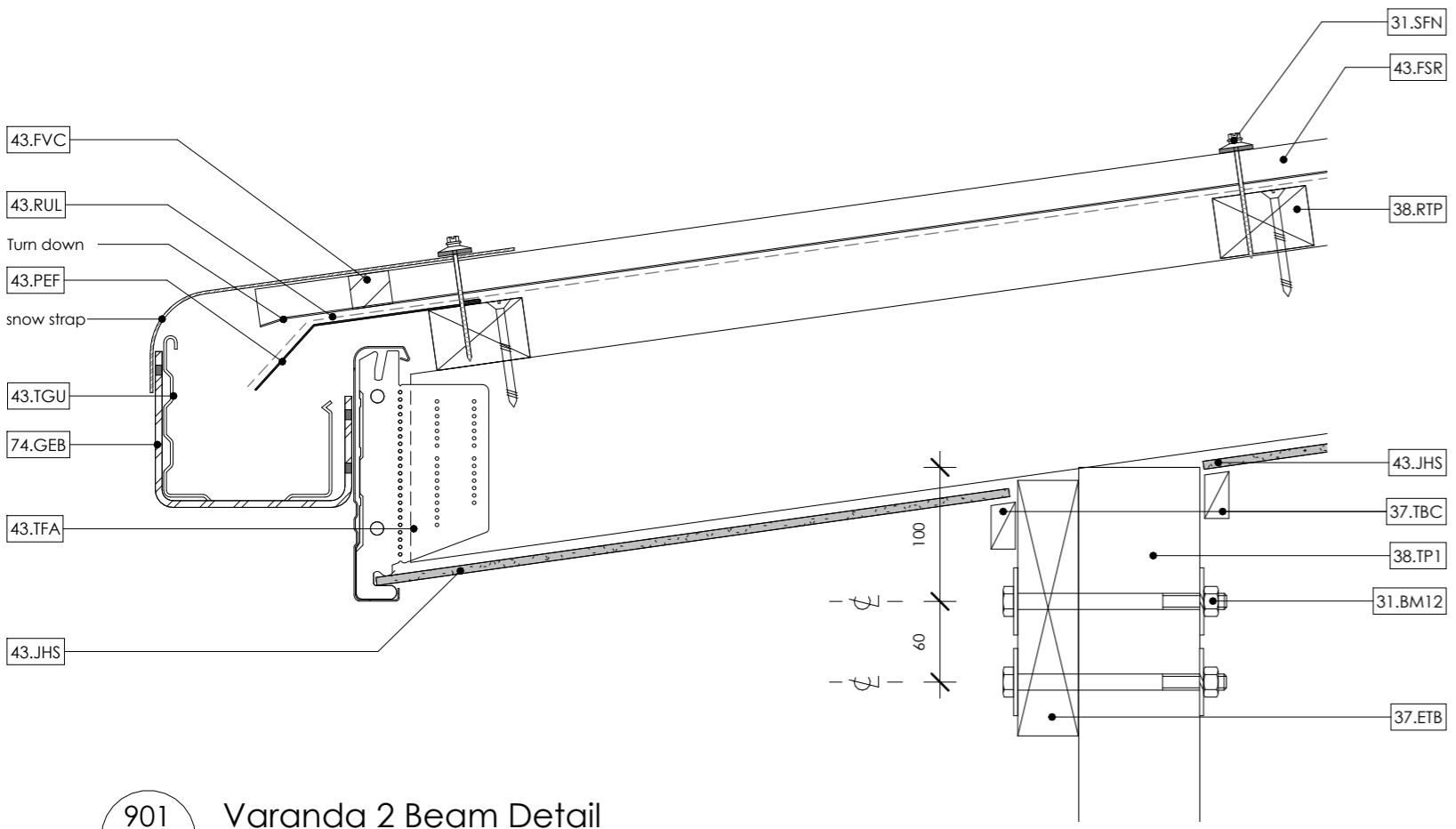

901 Varanda 2 Beam Detail

A5.00 1 : 5 @ A3

Keynote Legend Per Page

Key Value	Keynote Text
43.TGU	TYPICAL GUTTER: Colorcote MagnaFlow steel 125mm Box gutter with external brackets and snow straps @ 500crs fixed in accordance with manufacturers recommendations and colour matched to roofing.
47.RAB	Rigid Air Barrier: James Hardie RAB Board 6mm.
47.SNF	SEAL: apply continuous 6mm bead of Seal n Flex-1 or Sikaflex 11FC adhesive sealant.
51.HGL	13mm GIB Standard interior wall lining, level 4 plaster and paint finish
53.GCL	GIB BOARD CEILING LINING: 13mm Standary GIB board ceiling lining, level 4 GIB stopping and 3 coat paint finish, supported by rondo suspended ceiling grid system. Refer to Colour Schedule.
74.GEB	BRACKET: External Gutter bracket spacings 750mm.

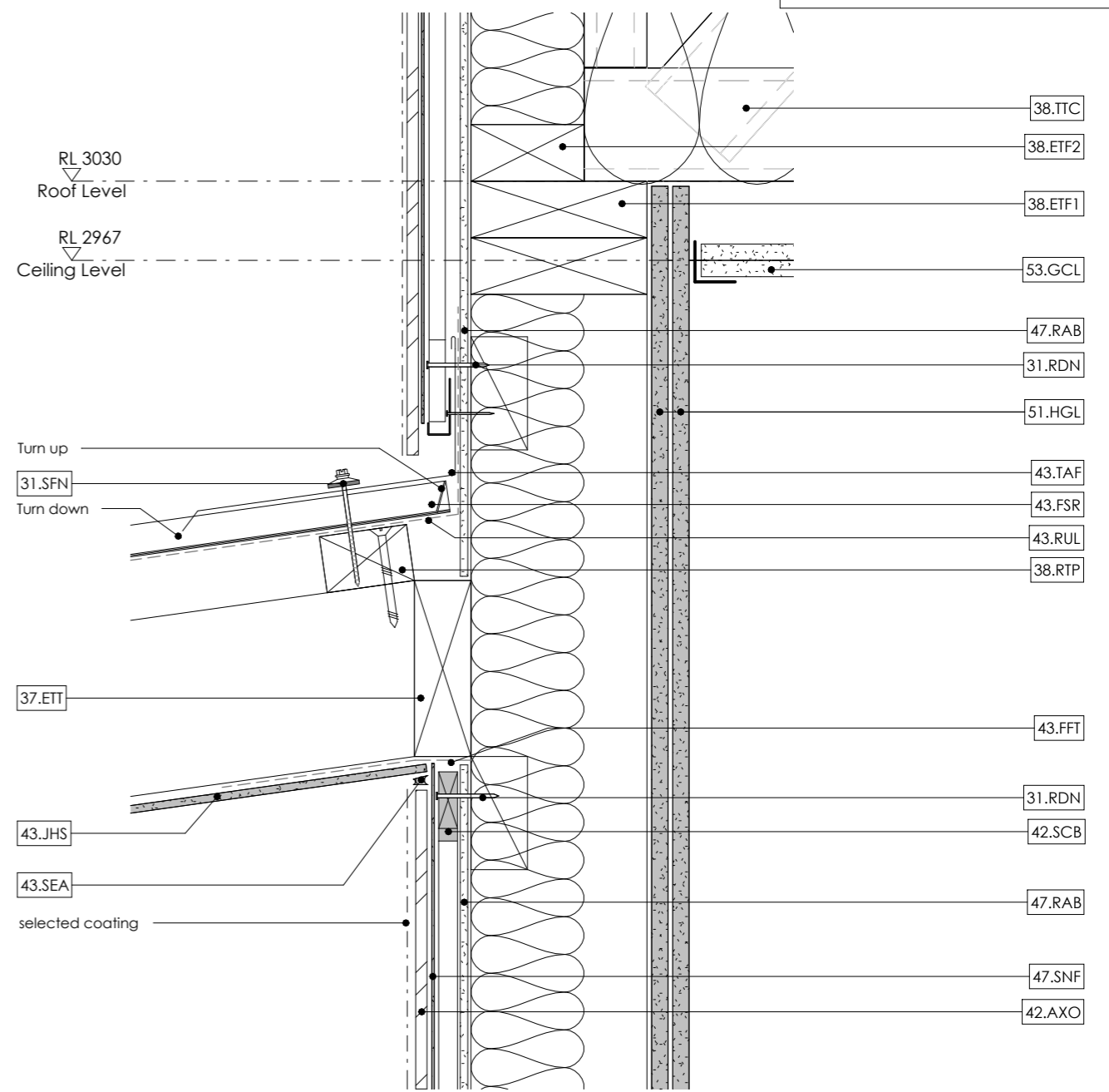

902 Varanda 2 Stringer Detail

A5.00 1 : 5 @ A3

General Notes:

1. This drawing shall be read in conjunction with all other drawings & specifications.
2. All work shall be strictly in accordance with the New Zealand Building Code, Local Territorial Authority Requirements, OSH Requirements & Regulations, and any other Statutory Requirements that may be applicable to this project.
3. All work shall be of best trade practice.
4. Do not scale from this drawing. Use only figured dimensions. The Contractor shall verify all dimensions on site, and report any discrepancies to the Architect before commencing work.



Copyright:
The copyright of this drawings remains the property of DLA Architects Limited and may only be used or re-used with DLA's prior written consent.

Project:
Clandeboy Bio Mass Control Room & Amenities

Client:
Fonterra Clandeboy

Drawing Title:
Varanda Detail 2
CAD File:

REV.	DATE	REVISION DETAILS
1	28/08/24	Tender Issue
0	27/05/24	First Issue

Scale: 1 : 5 @ A3	Date: 29/08/24	Drawn: MX
Job No: C919	Designed: MA	Checked: CG
Drawing No: A8.10	Revision No: 1	

General Notes:

1. This drawing shall be read in conjunction with all other drawings & specifications.
2. All work shall be strictly in accordance with the New Zealand Building Code, Local Territorial Authority Requirements, OSH Requirements & Regulations, and any other Statutory Requirements that may be applicable to this project.
3. All work shall be of best trade practice.
4. Do not scale from this drawing. Use only figured dimensions. The Contractor shall verify all dimensions on site, and report any discrepancies to the Architect before commencing work.

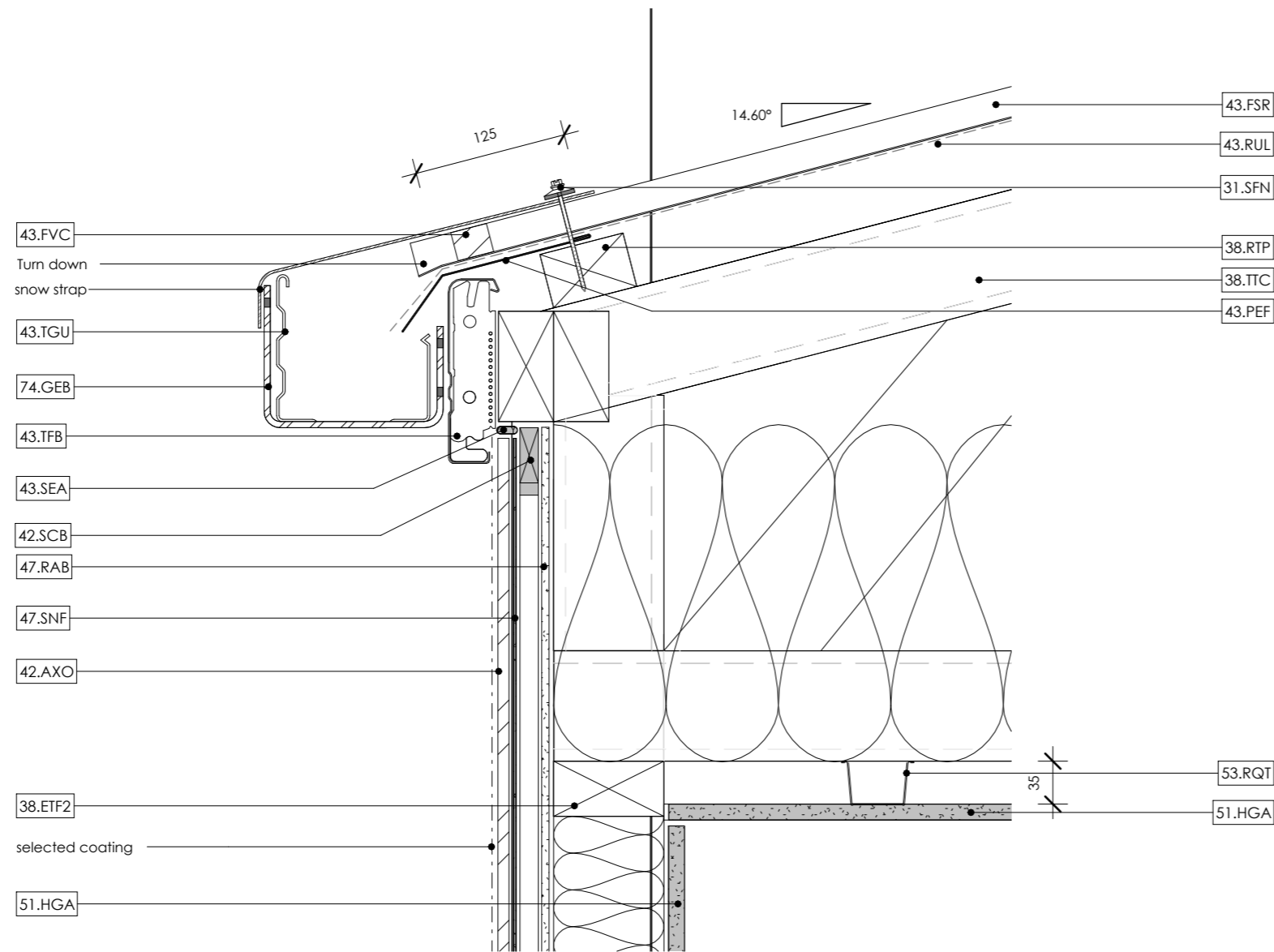

Keynote Legend Per Page	
Key Value	Keynote Text
31.SFN	SCREW: min. 12 gauge screw fixing w/ neoprene washer over EPDM washer where required to allow for expansion. 6T3 - Hit 2, Miss 2, Hit 1. 75mm nail.
38.ETF2	EXTERNAL TIMBER FRAMING: Construct with 90 x 45mm, H1.2 studs at 600mm centres max.
38.RTP	TIMBER PURLINS: 70x45mm SG8 H1.2 treated timber purlins with 900mm spacing, max fixed with 1/10g Self-drilling screw, 80mm long, at each rafter/truss.
38.TTC	TIMBER TRUSS CONSTRUCTION: Timber trusses @ 900 crs generally designed, fabricated and fixed according to the engineered truss design and specifications.
42.AXO	AXON Panel: 9mm thick x 1200mm wide Axon Panel, over CLD cavity battens fixed to wall framing, over RAB board to new timber wall framing. To be installed in accordance with Axon Panel Technical Specification. Coat paint finish to match existing cladding, unless noted otherwise.
42.SCB	CAVITY BATTEN: 70 x 19mm Hardie CLD Structural Cavity Batten installed in 20mm drained cavity fixing.
43.FSR	ROOFING: Freeman Six Rib Roofing 0.55 BMT Colorcote MagnaFlow pre-finished steel trapezoidal roofing. Colour match the existing.
43.FVC	foam vented cavity closure strip.
43.PEF	EAVE FLASHING: 0.55 BMT pre-finished eave flashing.
43.RUL	UNDERLAY: Thermakraft Covertek 407 roof underlay
43.SEA	BRANZ approved flexible sealant.
43.TFB	TYPICAL METAL FASCIA/BARGE BOARD 147mm: 0.55BMT Colorcote MagnaFlow formed steel fascia with clips fixed to framing. Colorcote MagnaFlow gutters packed off fascia with 6mm gap behind.
43.TGU	TYPICAL GUTTER: Colorcote MagnaFlow steel 125mm Box gutter with external brackets and snow straps @ 500crs fixed in accordance with manufacturers recommendations and colour matched to roofing.
47.RAB	Rigid Air Barrier: James Hardie RAB Board 6mm.
47.SNF	SEAL: apply continuous 6mm bead of Seal n Flex-1 or Sikaflex 11FC adhesive sealant.
51.HGA	13mm GIB Aqualine interior wall lining, level 4 plaster and paint finish
53.RQT	Rondo track 310mm.
74.GEB	BRACKET: External Gutter bracket spacings 750mm.

100 Gutter Detail No Eaves
A5.02 1 : 5 @ A3

Keynote Legend Per Page

Key Value	Keynote Text
38.ITF	INTERNAL TIMBER FRAMING: Construct with 90mm x 45mm SG8 h1.2 framing with studs @ 600mm crs to nzs3604:2011. Dwang at 800mmcrs. Dwang for all fittings, fixtures, linings, bracing panels & trims. DPC between bottom plate and conc. Slab.
38.TLT	LINTEL: 240 x 90mm LVL Futurebuild H1.2 Lintel. Fix to wall framing with MiTek Lumberlok Lintel Fixing TYPE H.
51.HGL	13mm GIB Standard interior wall lining, level 4 plaster and paint finish
53.SFC	Standard Fiber Cement sheet fix onto existing ceiling grid.

General Notes:

1. This drawing shall be read in conjunction with all other drawings & specifications.
2. All work shall be strictly in accordance with the New Zealand Building Code, Local Territorial Authority Requirements, OSH Requirements & Regulations, and any other Statutory Requirements that may be applicable to this project.
3. All work shall be of best trade practice.
4. Do not scale from this drawing. Use only figured dimensions. The Contractor shall verify all dimensions on site, and report any discrepancies to the Architect before commencing work.

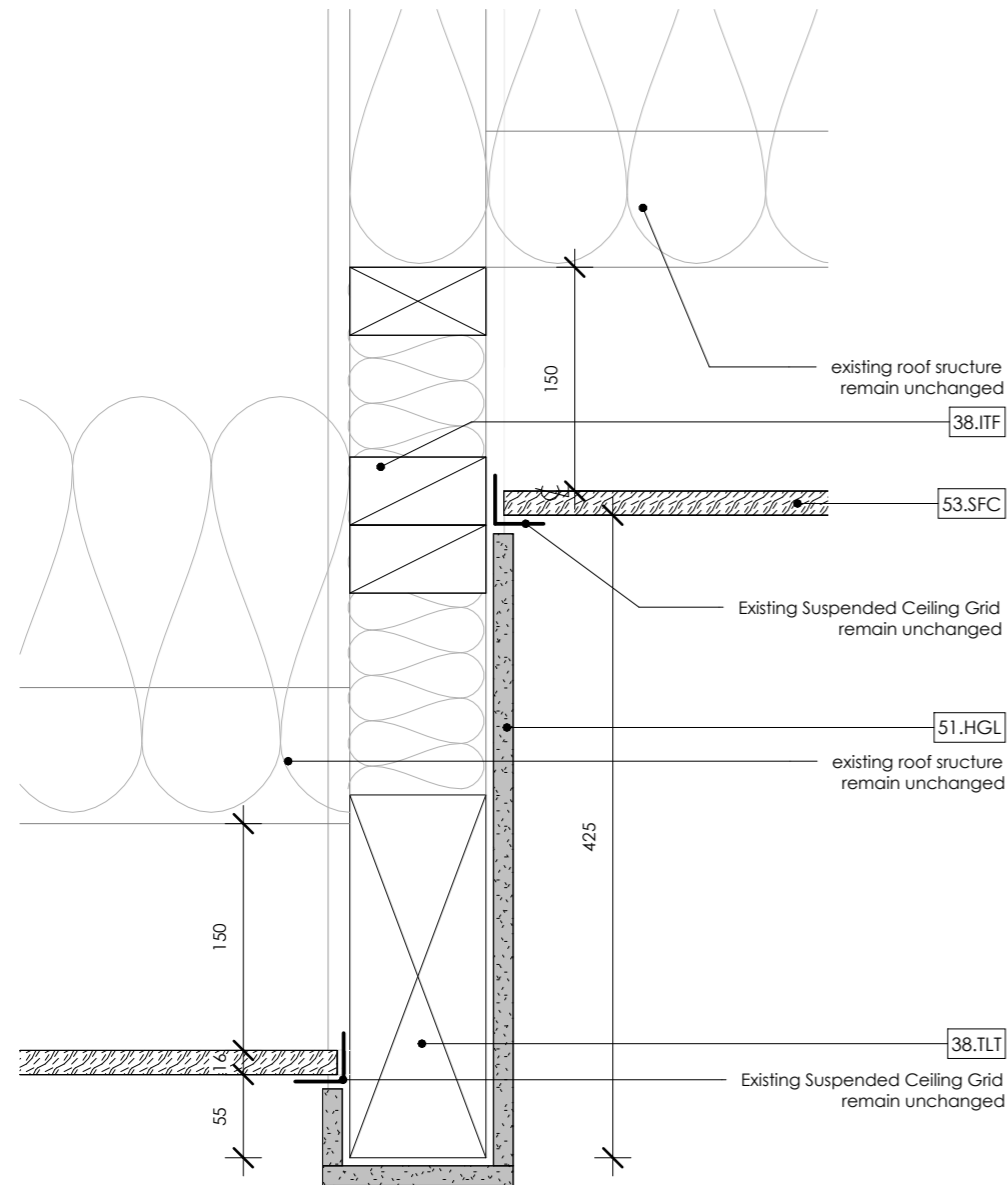

TYPE H 13.5kN

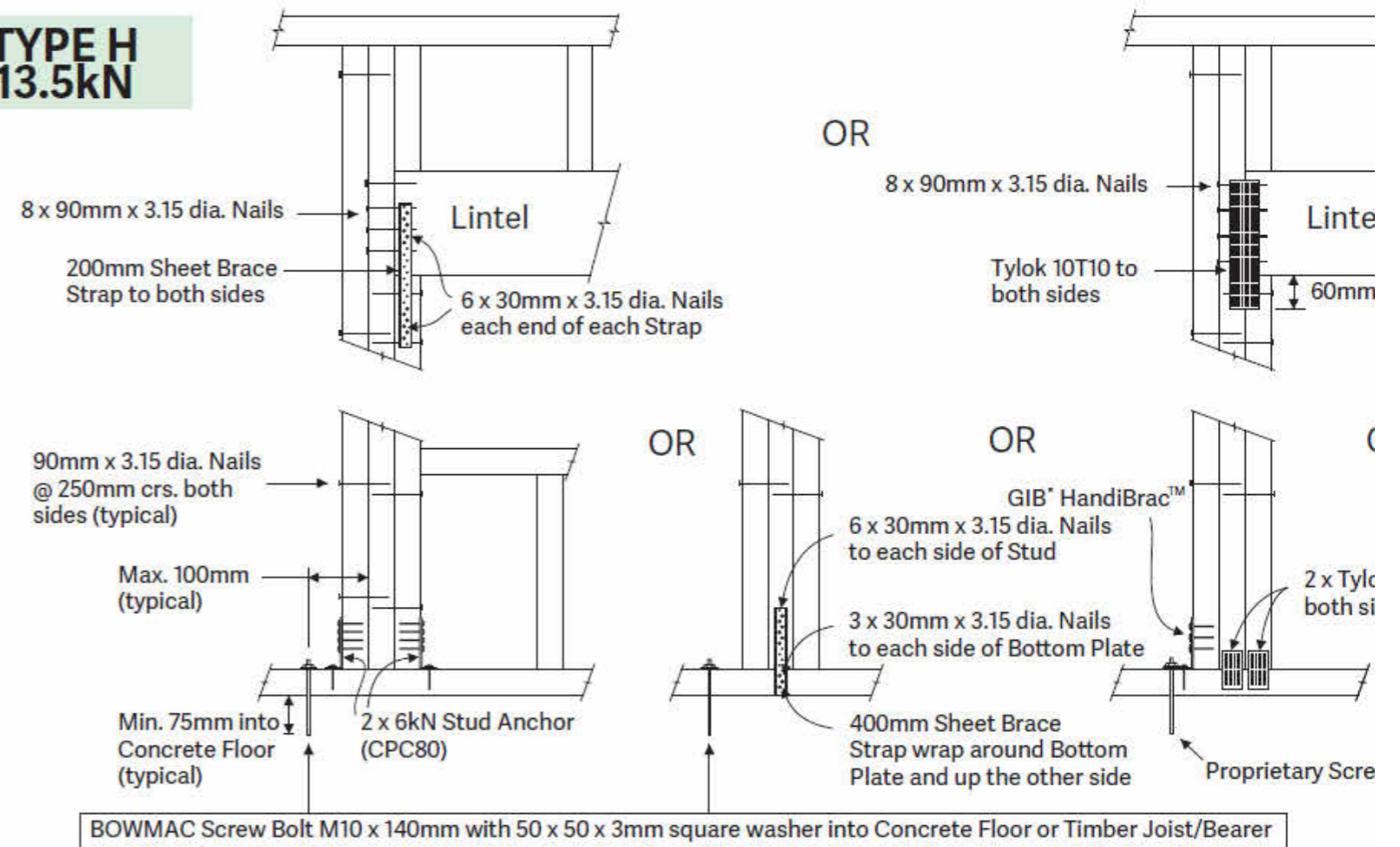

110

Beam Detail

A5.02

1 : 5 @ A3

Copyright:

The copyright of this drawings remains the property of DLA Architects Limited and may only be used or re-used with DLA's prior written consent.

Project:

Clandeboyce Bio Mass Control Room & Amenities

Client:

Fonterra Clandeboyce



Drawing Title:

Internal Beam Detail

CAD File:

REV.	DATE	REVISION DETAILS
1	28/08/24	Tender Issue
0	27/05/24	First Issue

Scale:
1 : 5 @ A3

Date:
29/08/24

Drawn:
MX

Designed:
MA

Checked:
CG

Job No:
C919

Drawing No:
A8.12

Revision No:
1



timaru.
t: +64 3 683 1300
e: admin@dla.co.nz
49 george street,
timaru, 7910

General Notes:

1. This drawing shall be read in conjunction with all other drawings & specifications.
2. All work shall be strictly in accordance with the New Zealand Building Code, Local Territorial Authority Requirements, OSH Requirements & Regulations, and any other Statutory Requirements that may be applicable to this project.
3. All work shall be of best trade practice.
4. Do not scale from this drawing. Use only figured dimensions. The Contractor shall verify all dimensions on site, and report any discrepancies to the Architect before commencing work.

Keynote Legend Per Page

Key Value	Keynote Text
38.TTP	TIMBER PACKER.
55.SAF	SIKAFLEX SEALANT: continuous Sikaflex AT-Facade waterproof sealant / airseal over PEF rod to perimeter of trim cavity.
55.SSB	SUPPORT BAR: Sill support bar, pre-fill fixing holes with silicon sealant.
55.STP	SILL TIMBER PACKER: 25mm H3.2 treated timber reveal, 3 coat.
74.DCR	REINFORCEMENT: Drainage corner reinforcement to waterproofing membrane change of substrate in accordance with manufacturers details.
74.LAW	Liquid applied waterproofing (UV stable) to channel and face of slab.
74.MDR	MEMBRANE: Membrane dressed into reveal.

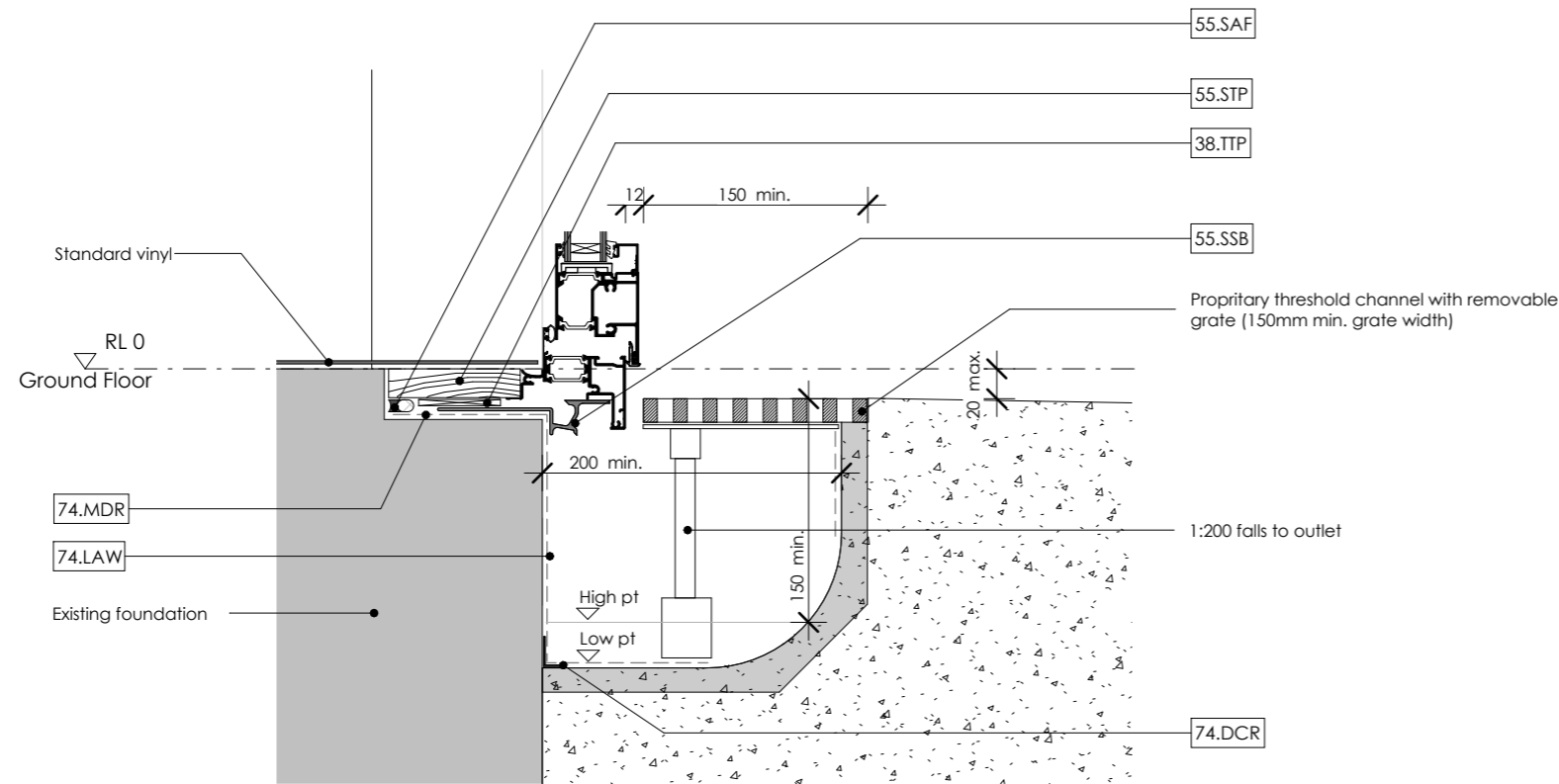

120 Channel Drain Detail
A2.61 1:5 @ A3

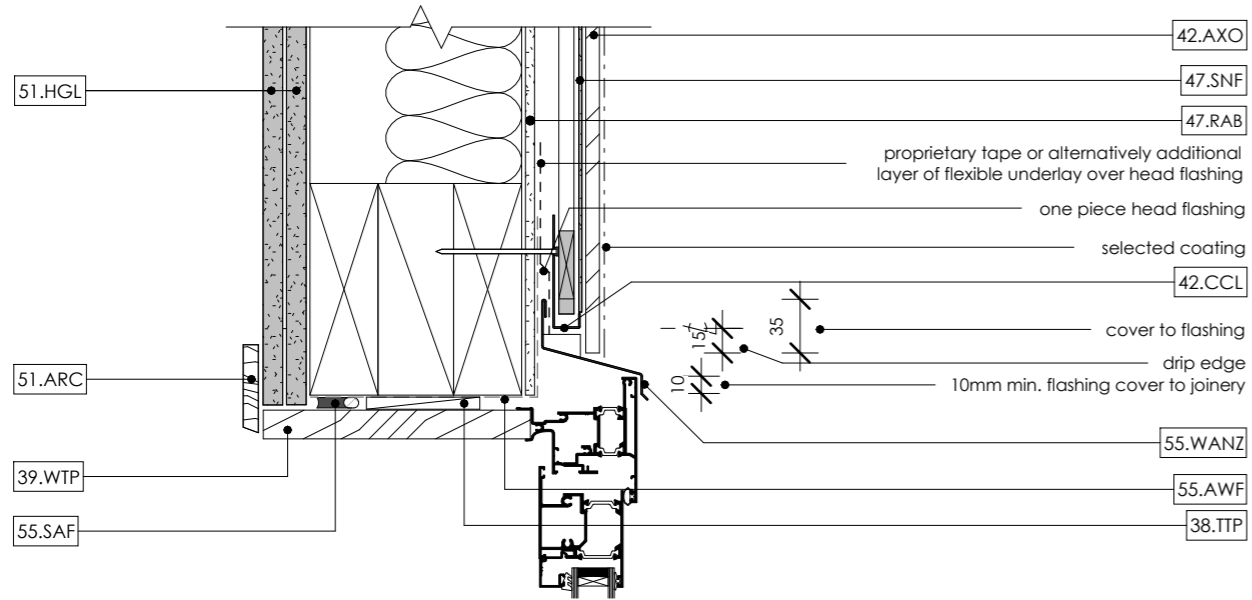

Keynote Legend Per Page	
Key Value	Keynote Text
38.TTP	TIMBER PACKER.
39.WTP	25mm H3.1 pre-primed, pine timber, flush reveals with enamel painted finish.
42.AXO	AXON Panel: 9mm thick x 1200mm wide Axon Panel, over CLD cavity battens fixed to wall framing, over RAB board to new timber wall framing. To be installed in accordance with Axon Panel Technical Specification. Coat paint finish to match existing cladding, unless noted otherwise.
42.CCL	CAVITY CLOSER: Cavity closure strip Hardie uPVC vent strip 75mm min upstand with 1000mm2 of opening per lineal metre. Keep clear of debris.
42.SCB	CAVITY BATTEN: 70 x 19mm Hardie CLD Structural Cavity Batten installed in 20mm drained cavity fixing.
43.DPC	DPC to provide separation of metal capping and timber.
47.RAB	Rigid Air Barrier: James Hardie RAB Board 6mm.
47.SNF	SEAL: apply continuous 6mm bead of Seal n Flex-1 or Sikaflex 11FC adhesive sealant.
51.ARC	ARCHITRAVE: 60x18mm timber architrave with enamel painted finish
51.HGL	13mm GIB Standard interior wall lining, level 4 plaster and paint finish
55.AWF	FLASHING TAPE: Thermakraft Thermaflash flashing tape to run perimeter of opening, lap 50mm minimum over wall underlay/RAB
55.SAF	SIKAFLEX SEALANT: continuous Sikaflex AT-Facade waterproof sealant / airseal over PEF rod to perimeter of trim cavity.
55.SSB	SUPPORT BAR: Sill support bar, pre-fill fixing holes with silicon sealant.
55.STP	SILL TIMBER PACKER: 25mm H3.2 treated timber reveal, 3 coat.
55.TUP	Turn-up flashing tape 100mm min. at trimmer studs.
55.WANZ	WANZ sill support bar.

- General Notes:**
1. This drawing shall be read in conjunction with all other drawings & specifications.
 2. All work shall be strictly in accordance with the New Zealand Building Code, Local Territorial Authority Requirements, OSH Requirements & Regulations, and any other Statutory Requirements that may be applicable to this project.
 3. All work shall be of best trade practice.
 4. Do not scale from this drawing. Use only figured dimensions. The Contractor shall verify all dimensions on site, and report any discrepancies to the Architect before commencing work.

211 Exterior Door Head Detail

A5.01 1 : 5 @ A3

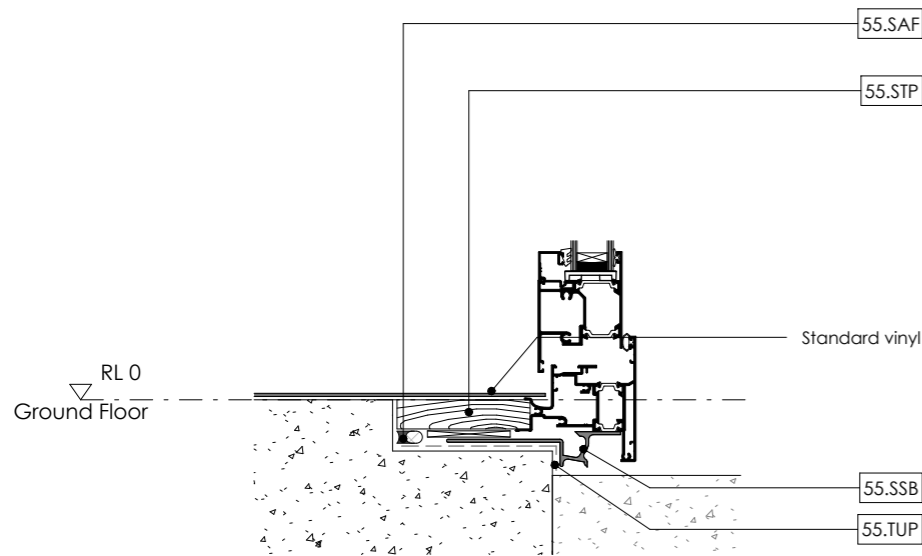

212 Exterior Door Sill Detail

A4.00 1 : 5 @ A3

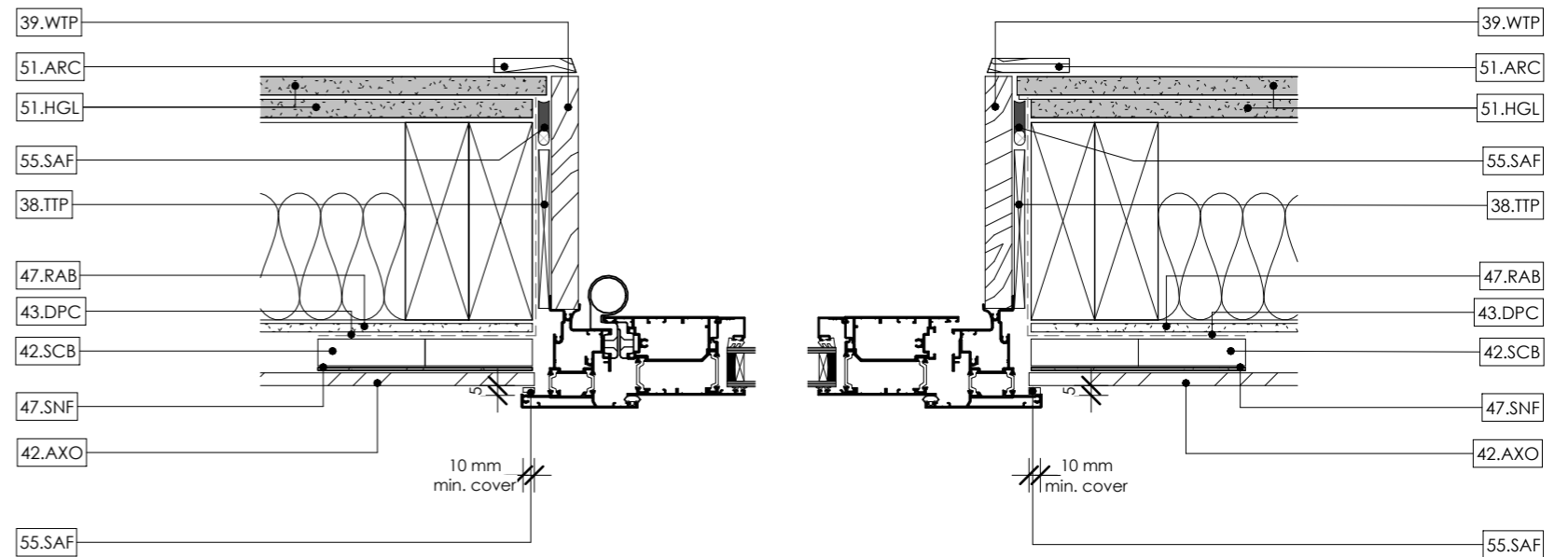

213 Exterior Door Jamb Detail

A5.01 1 : 5 @ A3

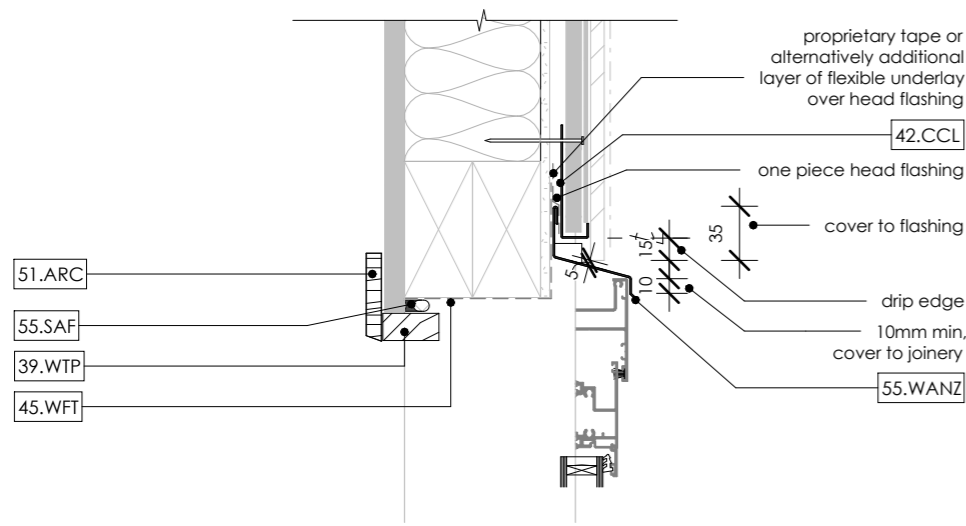

221 Exterior Sliding Door Head
1 : 5 @ A3

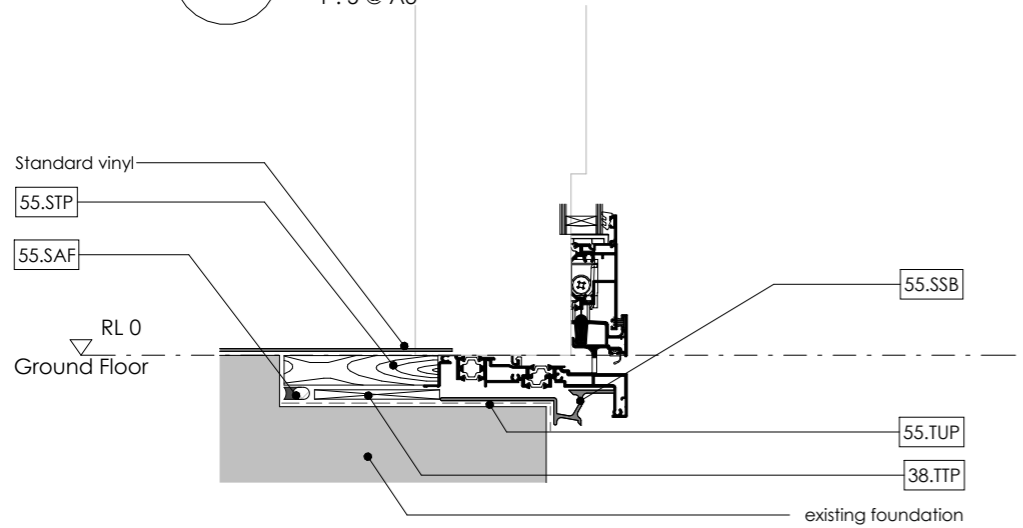

222 Exterior Sliding Door Sill
1 : 5 @ A3

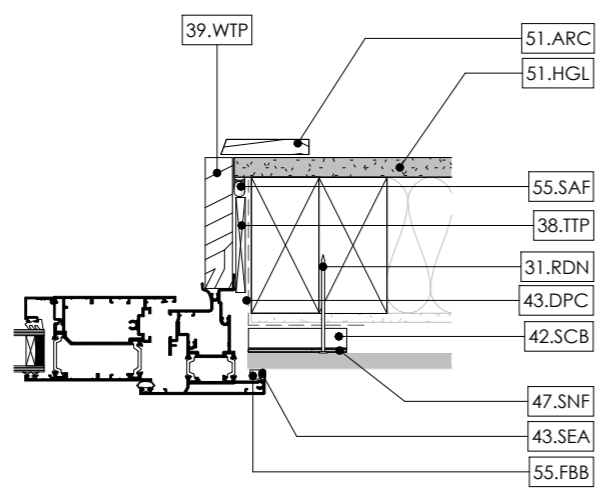

224 Door and Window Section
A4.02 1 : 5 @ A3

Keynote Legend Per Page	
Key Value	Keynote Text
31.RDN	65x2.8mm Round Drive ring shank nails for batten fixing
38.TTP	TIMBER PACKER.
39.WTP	25mm H3.1 pre-primed, pine timber, flush reveals with enamel painted finish.
42.CCL	CAVITY CLOSER: Cavity closure strip Hardie uPVC vent strip 75mm min upstand with 1000mm2 of opening per lineal metre. Keep clear of debris.
42.SCB	CAVITY BATTEN: 70 x 19mm Hardie CLD Structural Cavity Batten installed in 20mm drained cavity fixing.
43.DPC	DPC to provide separation of metal capping and timber.
43.SEA	BRANZ approved flexible sealant.
45.WFT	55: Selected window flashing tape - refer specification
47.SNF	SEAL: apply continuous 6mm bead of Seal n Flex-1 or Sikaflex 11FC adhesive sealant.
51.ARC	ARCHITRAVE: 60x18mm timber architrave with enamel painted finish
51.HGL	13mm GIB Standard interior wall lining, level 4 plaster and paint finish
55.FBB	Foam bound breaker.
55.SAF	SIKAFLEX SEALANT: continuous Sikaflex AT-Facade waterproof sealant / airseal over PEF rod to perimeter of trim cavity.
55.SSB	SUPPORT BAR: Sill support bar, pre-fill fixing holes with silicon sealant.
55.STP	SILL TIMBER PACKER: 25mm H3.2 treated timber reveal, 3 coat.
55.TUP	Turn-up flashing tape 100mm min. at trimmer studs.
55.WANZ	WANZ sill support bar.

- General Notes:**
1. This drawing shall be read in conjunction with all other drawings & specifications.
 2. All work shall be strictly in accordance with the New Zealand Building Code, Local Territorial Authority Requirements, OSH Requirements & Regulations, and any other Statutory Requirements that may be applicable to this project.
 3. All work shall be of best trade practice.
 4. Do not scale from this drawing. Use only figured dimensions. The Contractor shall verify all dimensions on site, and report any discrepancies to the Architect before commencing work.

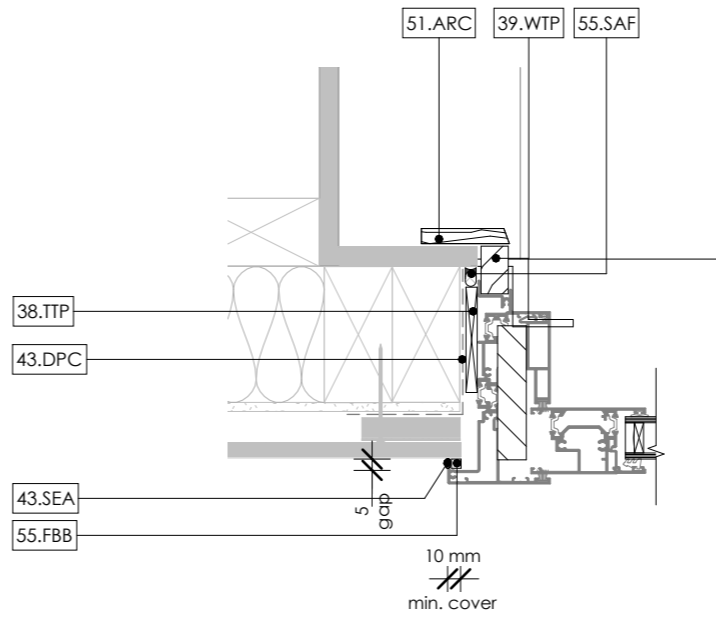

223 Exterior Sliding Door Jamb
1 : 5 @ A3

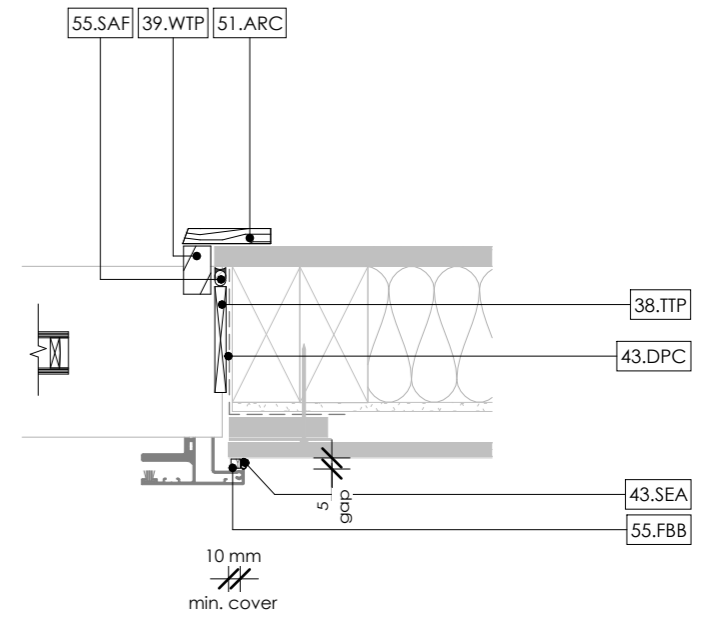

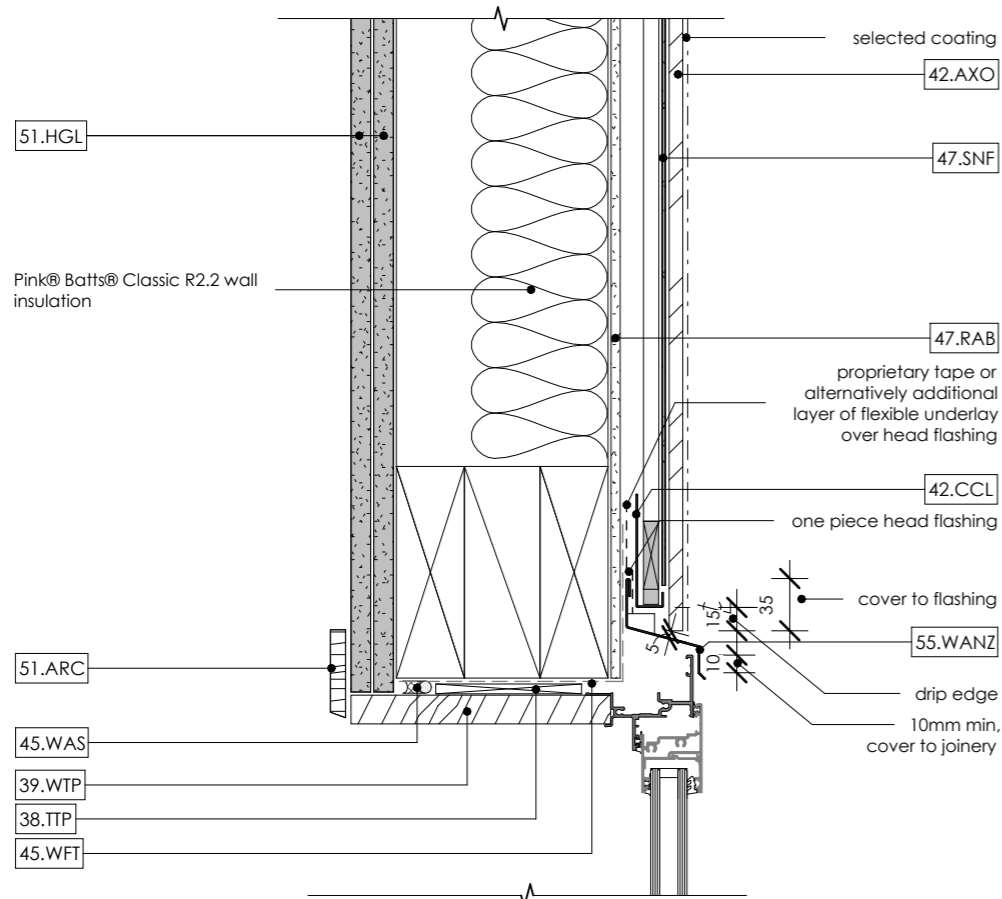

231 Window Head Detail
A4.00 1 : 5 @ A3

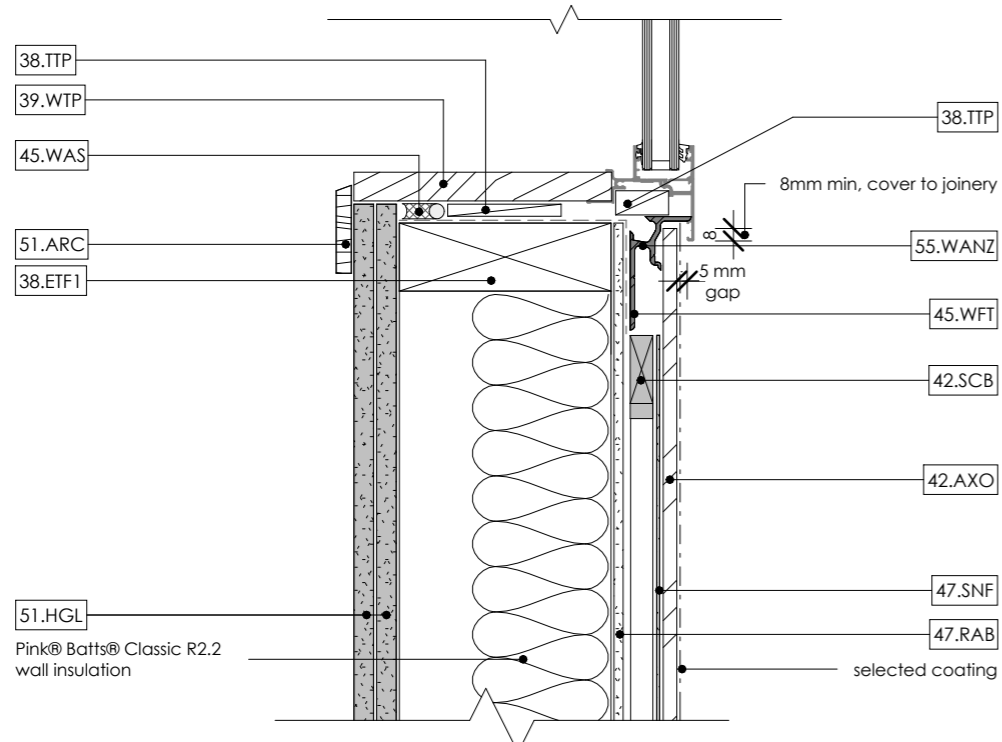

232 Window Sill Detail
A4.00 1 : 5 @ A3

Keynote Legend Per Page	
Key Value	Keynote Text
38.ETF1	EXTERNAL TIMBER FRAMING: 140 x 45mm, H1.2 studs at 600mm centres max.
38.TTP	TIMBER PACKER.
39.WTP	25mm H3.1 pre-primed, pine timber, flush reveals with enamel painted finish.
42.AXO	AXON Panel: 9mm thick x 1200mm wide Axon Panel, over CLD cavity battens fixed to wall framing, over RAB board to new timber wall framing. To be installed in accordance with Axon Panel Technical Specification. Coat paint finish to match existing cladding, unless noted otherwise.
42.CCL	CAVITY CLOSER: Cavity closure strip Hardie uPVC vent strip 75mm min upstand with 1000mm2 of opening per lineal metre. Keep clear of debris.
42.SCB	CAVITY BATTEN: 70 x 19mm Hardie CLD Structural Cavity Batten installed in 20mm drained cavity fixing.
45.WAS	WINDOW AIR SEAL: flexible wet sealant over PEF backing rod.
45.WFT	55: Selected window flashing tape - refer specification
47.RAB	Rigid Air Barrier: James Hardie RAB Board 6mm.
47.SNF	SEAL: apply continuous 6mm bead of Seal n Flex-1 or Sikaflex 11FC adhesive sealant.
51.ARC	ARCHITRAVE: 60x18mm timber architrave with enamel painted finish
51.HGL	13mm GIB Standard interior wall lining, level 4 plaster and paint finish
55.WANZ	WANZ sill support bar.

- General Notes:**
1. This drawing shall be read in conjunction with all other drawings & specifications.
 2. All work shall be strictly in accordance with the New Zealand Building Code, Local Territorial Authority Requirements, OSH Requirements & Regulations, and any other Statutory Requirements that may be applicable to this project.
 3. All work shall be of best trade practice.
 4. Do not scale from this drawing. Use only figured dimensions. The Contractor shall verify all dimensions on site, and report any discrepancies to the Architect before commencing work.

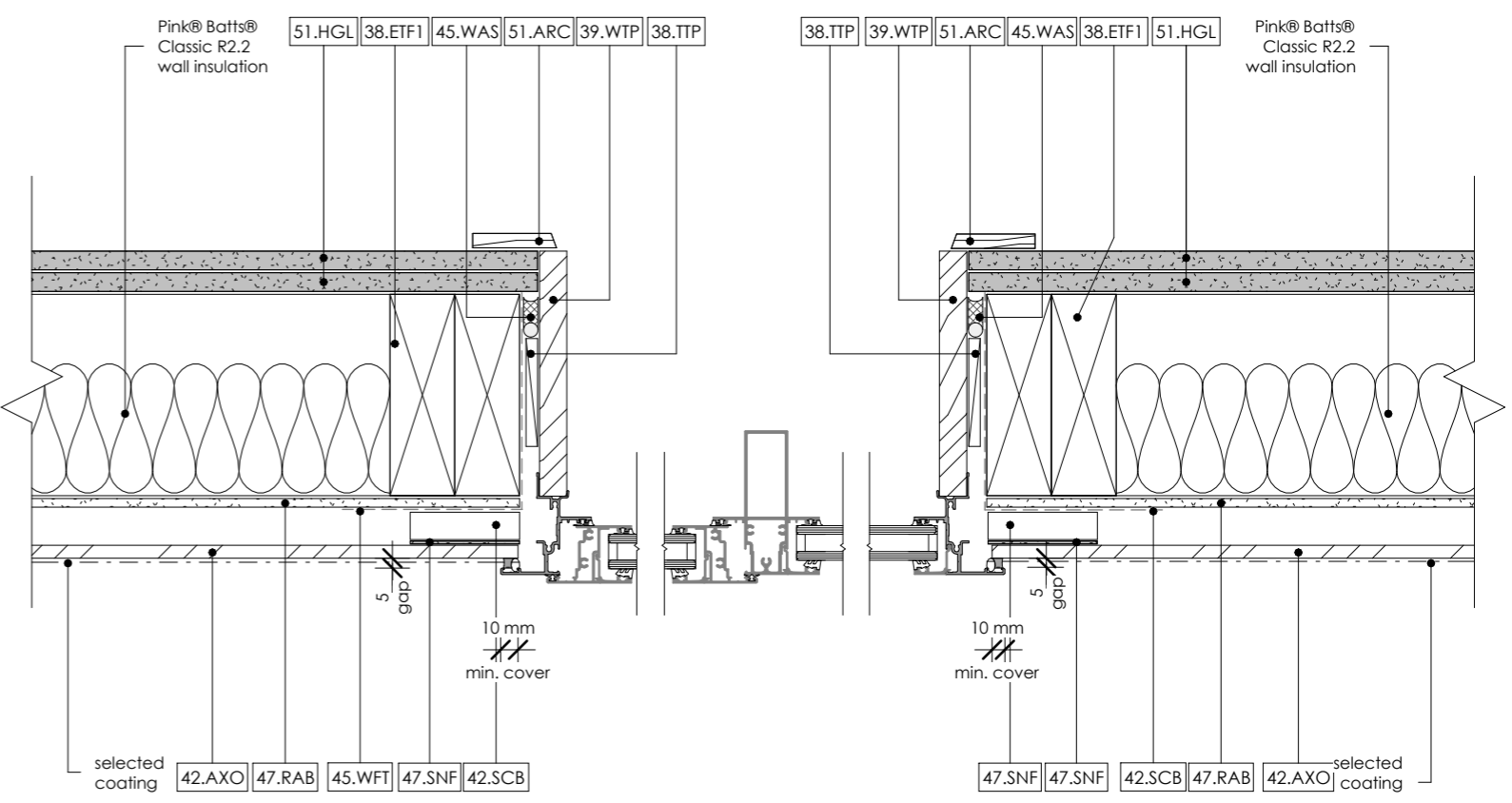

233 Window Jamb Detail
A4.00 1 : 5 @ A3



Copyright:
The copyright of this drawings remains the property of DLA Architects Limited and may only be used or re-used with DLA's prior written consent.

Project:
Clandeboyne Bio Mass Control Room & Amenities

Client:
Fonterra Clandeboyne

Drawing Title:
Exterior Window Details
CAD File:

REV.	DATE	REVISION DETAILS
1	28/08/24	Tender Issue
0	27/05/24	First Issue

Scale: 1 : 5 @ A3	Date: 29/08/24	Drawn: AG
Job No: C919	Designed: MA	Checked: CG
Drawing No: A8.23	Revision No: 1	

Keynote Legend Per Page

Key Value	Keynote Text
32.FSE	FOOTING: Concrete footing 200mm wide down to good ground. 140mm width, 150mm height nib with scabble to slab, d10 starters @ 600crs, D10 running length of nib.
32.FST	FOOTING: Concrete footing 200mm wide down to good ground. 90mm width, 150mm height nib with scabble to slab, d10 starters @ 600crs, D10 running length of nib.
38.ETF1	EXTERNAL TIMBER FRAMING: 140 x 45mm, H1.2 studs at 600mm centres max.
43.DPC	DPC to provide separation of metal capping and timber.
51.HGA	13mm GIB Aqualine interior wall lining, level 4 plaster and paint finish
52.TPI	PACKER: Timber packer over DPC.

General Notes:

1. This drawing shall be read in conjunction with all other drawings & specifications.
2. All work shall be strictly in accordance with the New Zealand Building Code, Local Territorial Authority Requirements, OSH Requirements & Regulations, and any other Statutory Requirements that may be applicable to this project.
3. All work shall be of best trade practice.
4. Do not scale from this drawing. Use only figured dimensions. The Contractor shall verify all dimensions on site, and report any discrepancies to the Architect before commencing work.

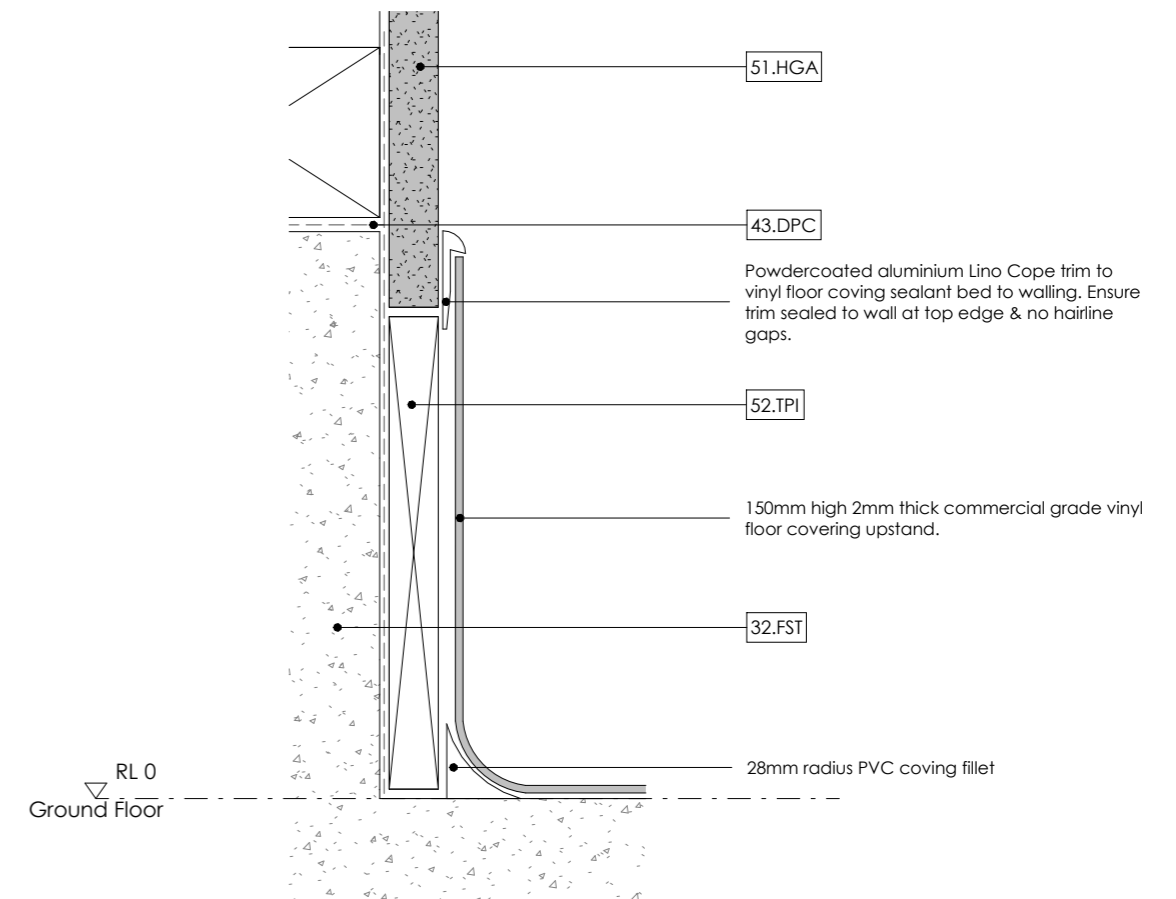
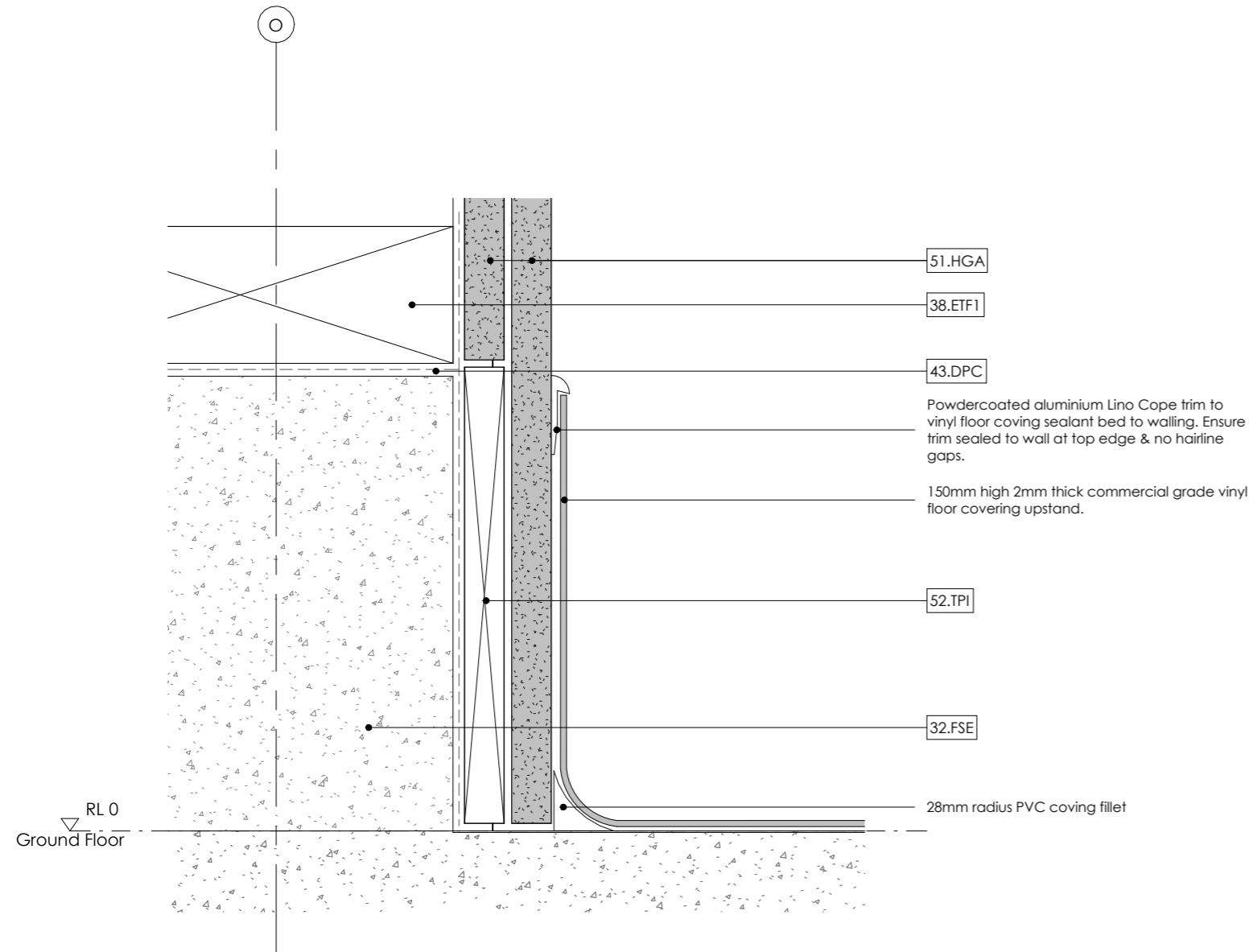

241 140mm Nib Vinyl Detail
A6.11 1 : 2 @ A3

242 90mm Nib Vinyl Detail
A6.16 1 : 2 @ A3

DRAFT



Copyright:
The copyright of this drawings remains the property of DLA Architects Limited and may only be used or re-used with DLA's prior written consent.

Project:
Clandeboye Bio Mass Control Room & Amenities

Client:
Fonterra Clandeboye

Drawing Title:
Exterior Nib To Vinyl Detail
CAD File:

REV.	DATE	REVISION DETAILS
1	28/08/24	Tender Issue
0	27/05/24	First Issue

Scale: 1 : 2 @ A3	Date: 29/08/24	Drawn: AG
Job No: C919	Designed: MA	Checked: CG
Drawing No: A8.24	Revision No: 1	

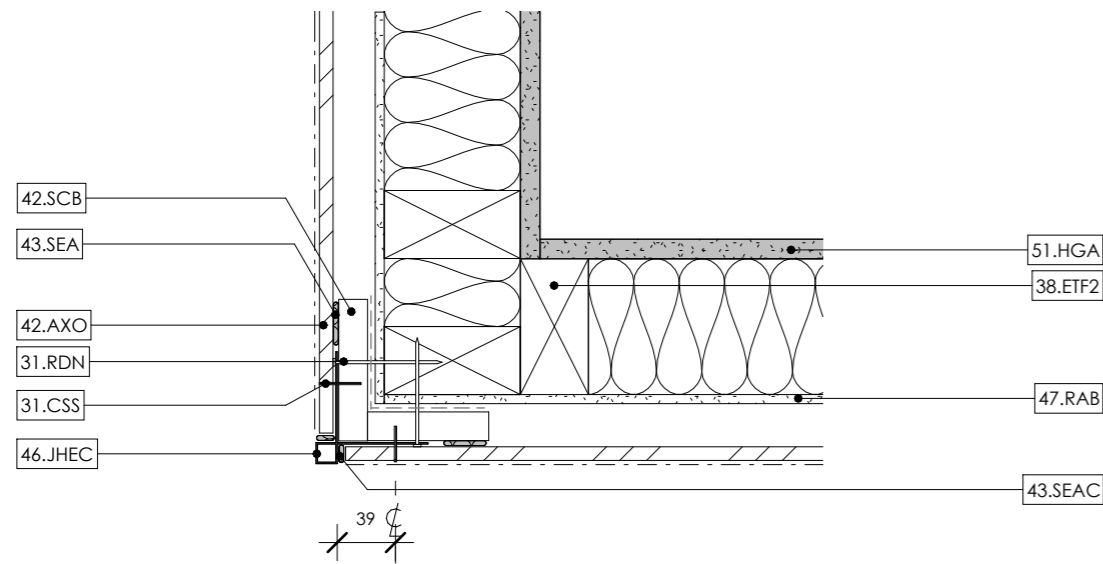

301 Wet Area Exterior Corner Detail

A4.02 1 : 5 @ A3

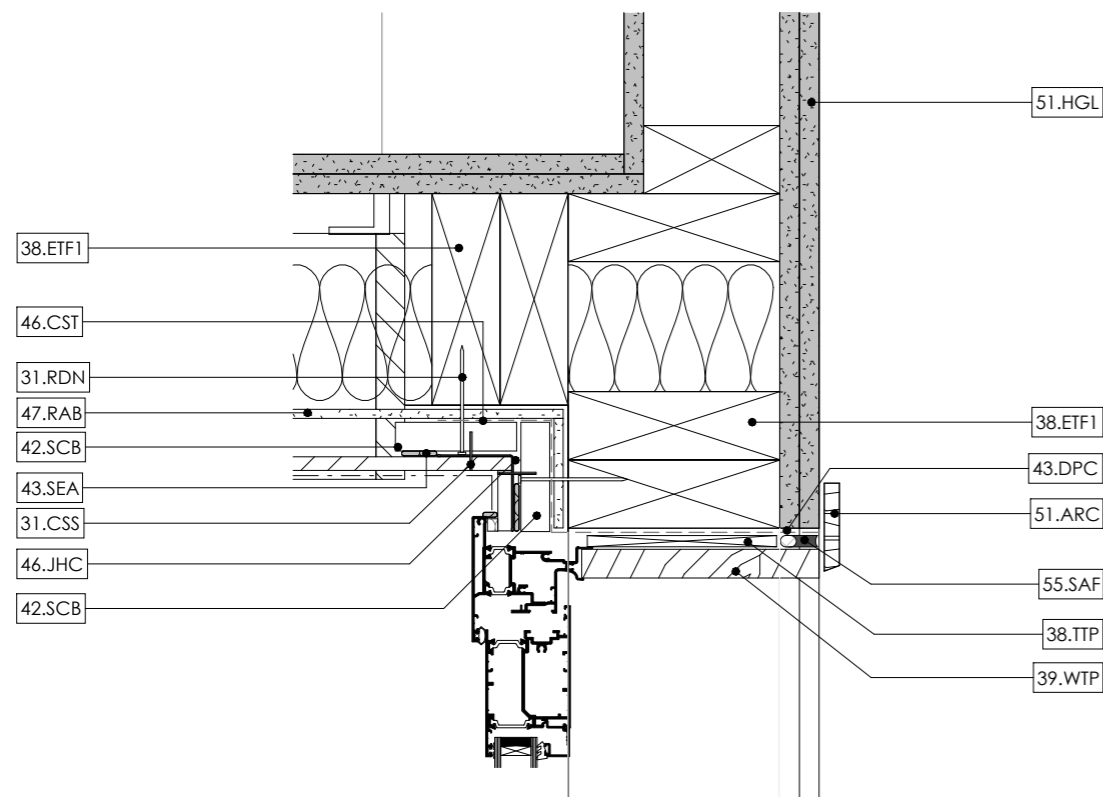

302 Boiler 1 & 2 Internal Corner

A4.00 1 : 5 @ A3

Keynote Legend Per Page	
Key Value	Keynote Text
31.CSS	25mm T head stainless steel brad nails for panel fixing.
31.RDN	65x2.8mm Round Drive ring shank nails for batten fixing
38.ETF1	EXTERNAL TIMBER FRAMING: 140 x 45mm, H1.2 studs at 600mm centres max.
38.ETF2	EXTERNAL TIMBER FRAMING: Construct with 90 x 45mm, H1.2 studs at 600mm centres max.
38.TTP	TIMBER PACKER.
39.WTP	25mm H3.1 pre-primed, pine timber, flush reveals with enamel painted finish.
42.AXO	AXON Panel: 9mm thick x 1200mm wide Axon Panel, over CLD cavity battens fixed to wall framing, over RAB board to new timber wall framing. To be installed in accordance with Axon Panel Technical Specification. Coat paint finish to match existing cladding, unless noted otherwise.
42.SCB	CAVITY BATTEN: 70 x 19mm Hardie CLD Structural Cavity Batten installed in 20mm drained cavity fixing.
43.DPC	DPC to provide separation of metal capping and timber.
43.SEA	BRANZ approved flexible sealant.
43.SEAC	Edge to be sealed before fixing typical 2mm maximum gap.
46.CST	75mm wide sealing tape.
46.JHC	Hardie 9mm aluminium internal corner.
46.JHEC	Hardie 9mm Panel Aluminium External Box Corner.
47.RAB	Rigid Air Barrier: James Hardie RAB Board 6mm.
51.ARC	ARCHITRAVE: 60x18mm timber architrave with enamel painted finish
51.HGA	13mm GIB Aqualine interior wall lining, level 4 plaster and paint finish
51.HGL	13mm GIB Standard interior wall lining, level 4 plaster and paint finish
55.SAF	SIKAFLEX SEALANT: continuous Sikaflex AT-Facade waterproof sealant / airseal over PEF rod to perimeter of trim cavity.

General Notes:

1. This drawing shall be read in conjunction with all other drawings & specifications.
2. All work shall be strictly in accordance with the New Zealand Building Code, Local Territorial Authority Requirements, OSH Requirements & Regulations, and any other Statutory Requirements that may be applicable to this project.
3. All work shall be of best trade practice.
4. Do not scale from this drawing. Use only figured dimensions. The Contractor shall verify all dimensions on site, and report any discrepancies to the Architect before commencing work.

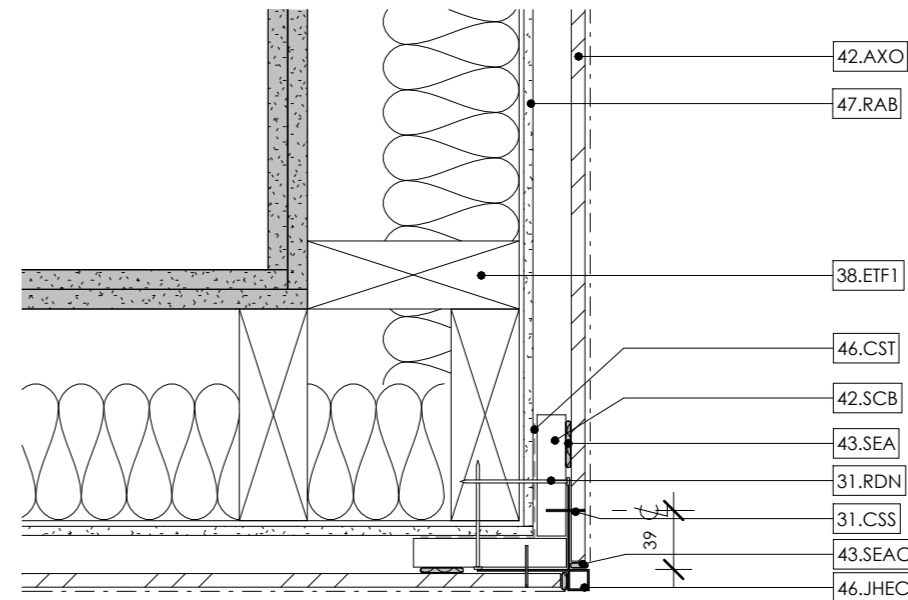

303 Boiler 1 & 2 External Corner

A4.00 1 : 5 @ A3

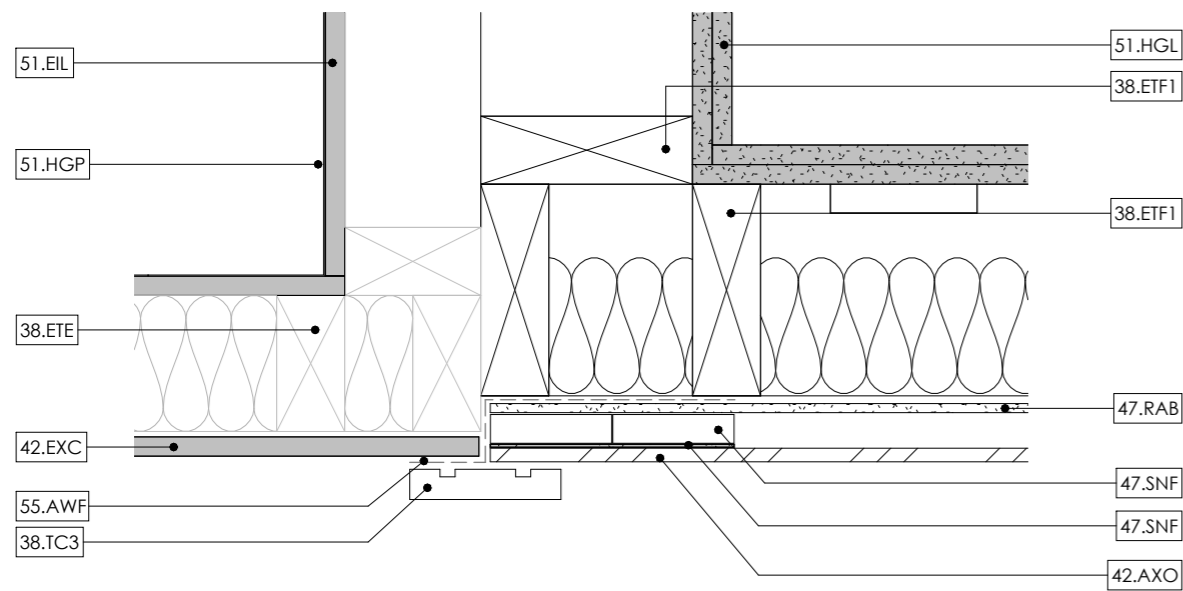

311 Boiler 1 &2 New Wall Join With Existing Structure

A4.00 1 : 5 @ A3

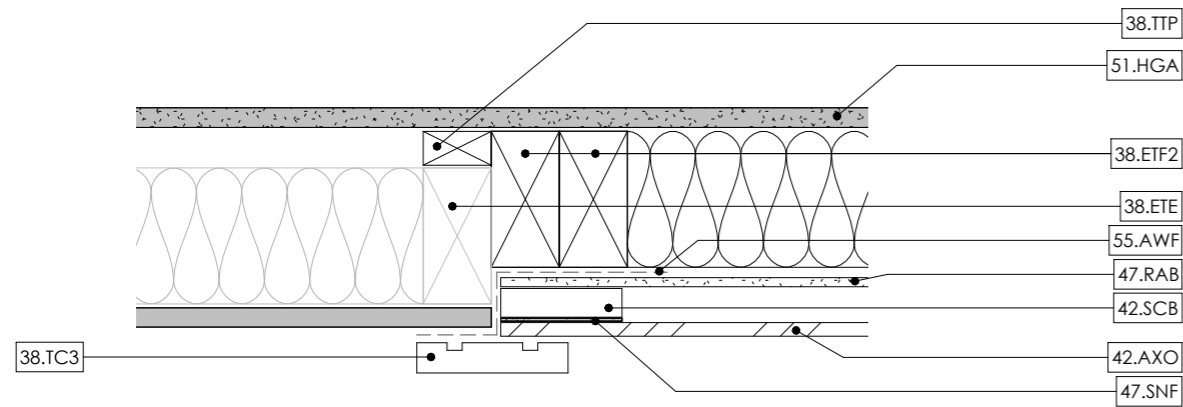

312 1 &2 New Wall Join With Existing Internal Corner

A4.00 1 : 5 @ A3

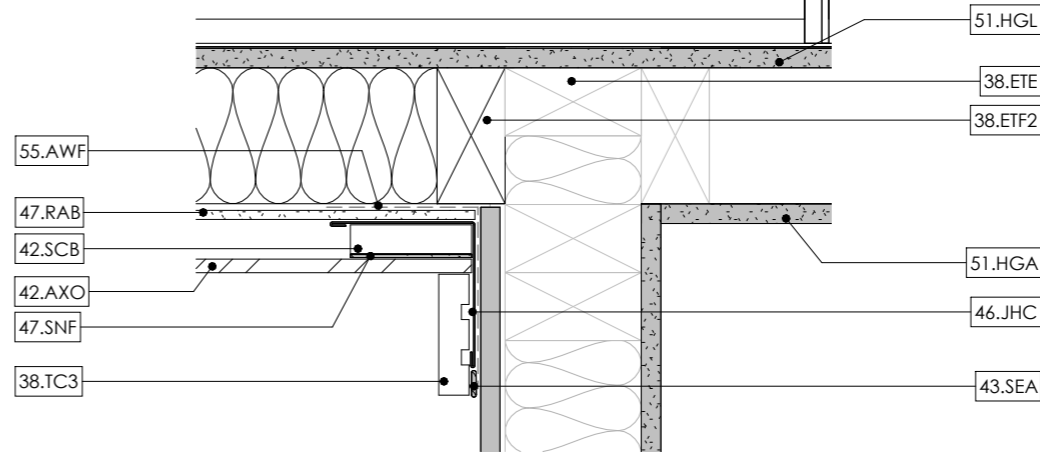

314 4, 5 & 6 Wall Join With Existing Internal Corner

A4.02 1 : 5 @ A3

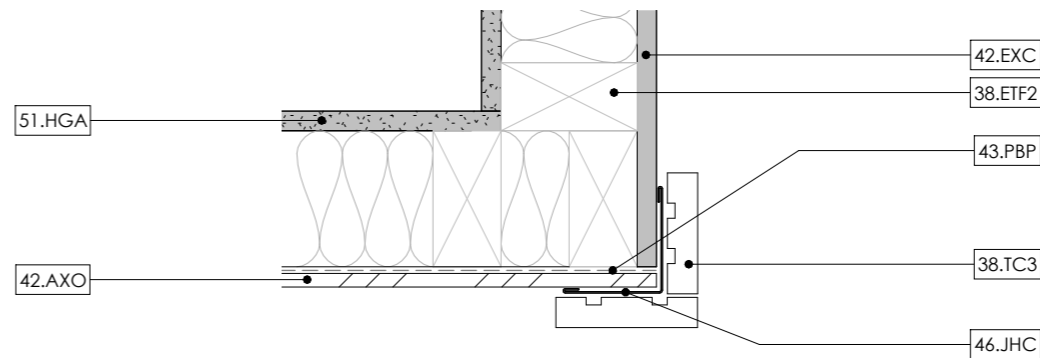

315 Direct Fix to Existing Frame Internal Corner

A4.02 1 : 5 @ A3

316 Direct Fix to Existing Frame External Corner

A4.02 1 : 5 @ A3

- General Notes:**
1. This drawing shall be read in conjunction with all other drawings & specifications.
 2. All work shall be strictly in accordance with the New Zealand Building Code, Local Territorial Authority Requirements, OSH Requirements & Regulations, and any other Statutory Requirements that may be applicable to this project.
 3. All work shall be of best trade practice.
 4. Do not scale from this drawing. Use only figured dimensions. The Contractor shall verify all dimensions on site, and report any discrepancies to the Architect before commencing work.

Keystone Legend Per Page

Key Value	Keystone Text
38.ETE	EXTERNAL TIMBER FRAMING EXISTING: 90 x 45mm, H1.2 treated timber wall framing remain unchanged.
38.ETF1	EXTERNAL TIMBER FRAMING: 140 x 45mm, H1.2 studs at 600mm centres max.
38.ETF2	EXTERNAL TIMBER FRAMING: Construct with 90 x 45mm, H1.2 studs at 600mm centres max.
38.TC3	H3.1 timber cavity battens 20mm.
38.TTP	TIMBER PACKER.
42.AXO	AXON Panel: 9mm thick x 1200mm wide Axon Panel, over CLD cavity battens fixed to wall framing, over RAB board to new timber wall framing. To be installed in accordance with Axon Panel Technical Specification. Coat paint finish to match existing cladding, unless noted otherwise.
42.EXC	Existing cladding.
42.SCB	CAVITY BATTEN: 70 x 19mm Hardie CLD Structural Cavity Batten installed in 20mm drained cavity fixing.
43.PBP	Building Paper under Axon Panel.
43.SEA	BRANZ approved flexible sealant.
46.JHC	Hardie 9mm aluminium internal corner.
47.RAB	Rigid Air Barrier: James Hardie RAB Board 6mm.
47.SNF	SEAL: apply continuous 6mm bead of Seal n Flex-1 or Sikaflex 11FC adhesive sealant.
51.EIL	Existing wall lining.
51.HGA	13mm GIB Aqualine interior wall lining, level 4 plaster and paint finish
51.HGL	13mm GIB Standard interior wall lining, level 4 plaster and paint finish
51.HGP	New paint finish over existing lining.
55.AWF	FLASHING TAPE: Thermakraft Thermaflash flashing tape to run perimeter of opening, lap 50mm minimum over wall underlay/RAB



Copyright:
The copyright of this drawings remains the property of DLA Architects Limited and may only be used or re-used with DLA's prior written consent.

Project:
Clandeboye Bio Mass Control Room & Amenities

Client:
Fonterra Clandeboye

Drawing Title:
Wall Junction Detail Join With Existing Structure
CAD File:

REV.	DATE	REVISION DETAILS
1	28/08/24	Tender Issue
0	27/05/24	First Issue

Scale: 1 : 5 @ A3	Date: 29/08/24	Drawn: MX
Job No: C919	Designed: MA	Checked: CG
Drawing No: A8.31	Revision No: 1	

Keynote Legend Per Page

Key Value	Keynote Text
31.CSS	25mm T head stainless steel brad nails for panel fixing.
31.RDN	65x2.8mm Round Drive ring shank nails for batten fixing
38.ETF1	EXTERNAL TIMBER FRAMING: 140 x 45mm, H1.2 studs at 600mm centres max.
42.AXO	AXON Panel: 9mm thick x 1200mm wide Axon Panel, over CLD cavity battens fixed to wall framing, over RAB board to new timber wall framing. To be installed in accordance with Axon Panel Technical Specification. Coat paint finish to match existing cladding, unless noted otherwise.
42.SCB	CAVITY BATTEN: 70 x 19mm Hardie CLD Structural Cavity Batten installed in 20mm drained cavity fixing.
43.SEA	BRANZ approved flexible sealant.
47.RAB	Rigid Air Barrier: James Hardie RAB Board 6mm.
47.SNF	SEAL: apply continuous 6mm bead of Seal n Flex-1 or Sikaflex 11FC adhesive sealant.
51.HGL	13mm GIB Standard interior wall lining, level 4 plaster and paint finish

General Notes:

1. This drawing shall be read in conjunction with all other drawings & specifications.
2. All work shall be strictly in accordance with the New Zealand Building Code, Local Territorial Authority Requirements, OSH Requirements & Regulations, and any other Statutory Requirements that may be applicable to this project.
3. All work shall be of best trade practice.
4. Do not scale from this drawing. Use only figured dimensions. The Contractor shall verify all dimensions on site, and report any discrepancies to the Architect before commencing work.

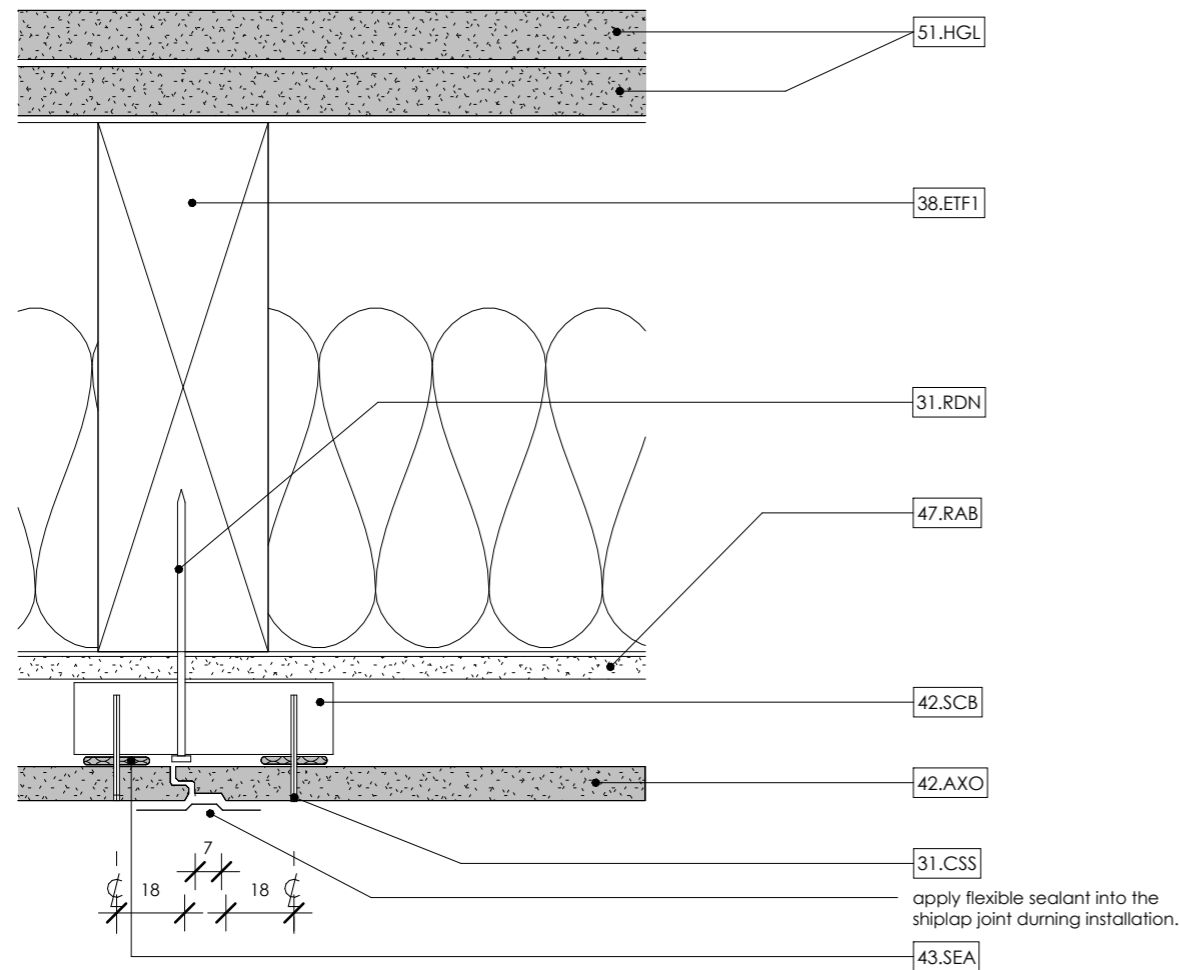

321 Axon Shiplap Joint

A4.00 1 : 2 @ A3

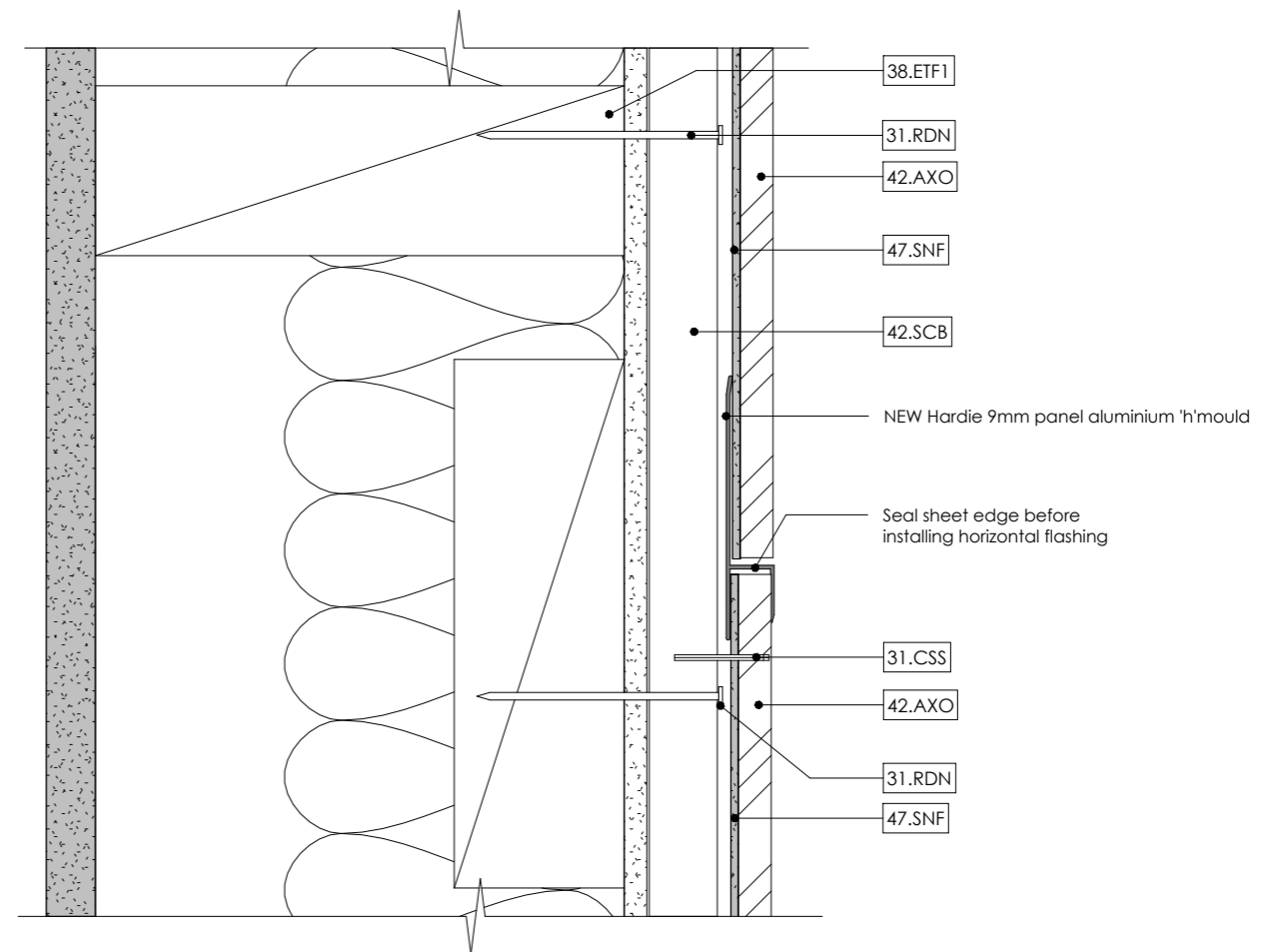

322 Axon Panel Horizontal h Moulding

A4.01 1 : 2 @ A3

General Notes:

1. This drawing shall be read in conjunction with all other drawings & specifications.
2. All work shall be strictly in accordance with the New Zealand Building Code, Local Territorial Authority Requirements, OSH Requirements & Regulations, and any other Statutory Requirements that may be applicable to this project.
3. All work shall be of best trade practice.
4. Do not scale from this drawing. Use only figured dimensions. The Contractor shall verify all dimensions on site, and report any discrepancies to the Architect before commencing work.

Keynote Legend Per Page	
Key Value	Keynote Text
31.SFN	SCREW: min. 12 gauge screw fixing w/ neoprene washer over EPDM washer where required to allow for expansion. 6T3 - Hit 2, Miss 2, Hit 1. 75mm nail.
38.RTP	TIMBER PURLINS: 70x45mm SG8 H1.2 treated timber purlins with 900mm spacing, max fixed with 1/10g Self-drilling screw, 80mm long, at each rafter/truss.
38.TTC	TIMBER TRUSS CONSTRUCTION: Timber trusses @ 900 crs generally designed, fabricated and fixed according to the engineered truss design and specifications.
43.FSR	ROOFING: Freeman Six Rib Roofing 0.55 BMT Colorcote MagnaFlow pre-finished steel trapezoidal roofing. Colour match the existing.

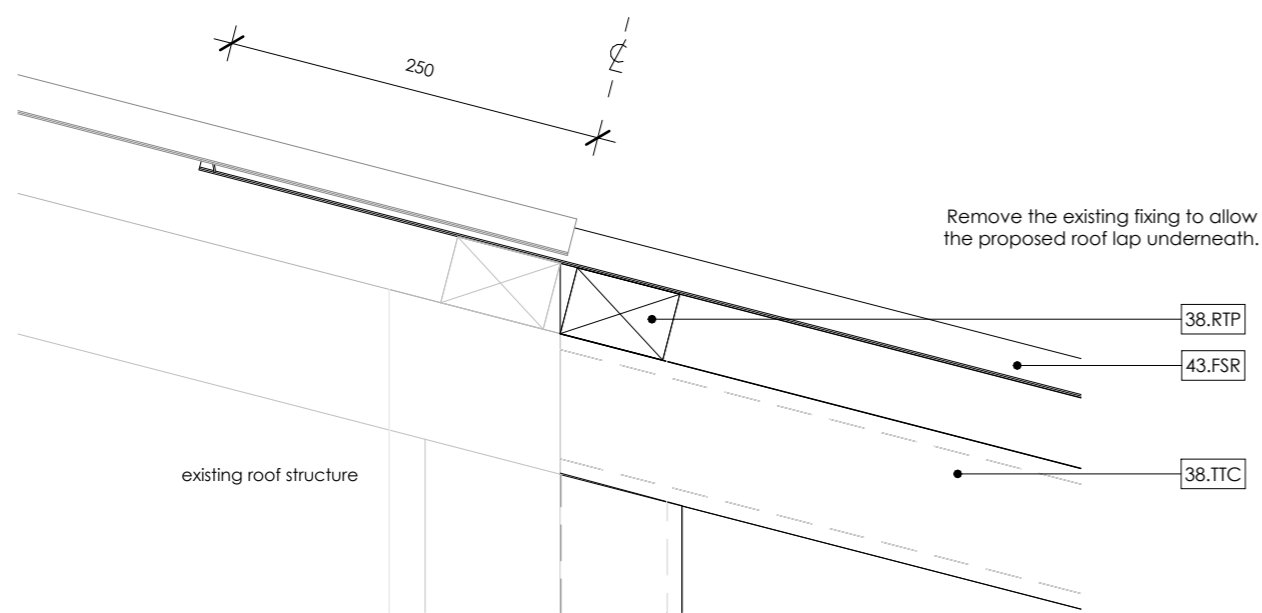

331 Roof Lap Under Existing
A4.02 1 : 5 @ A3

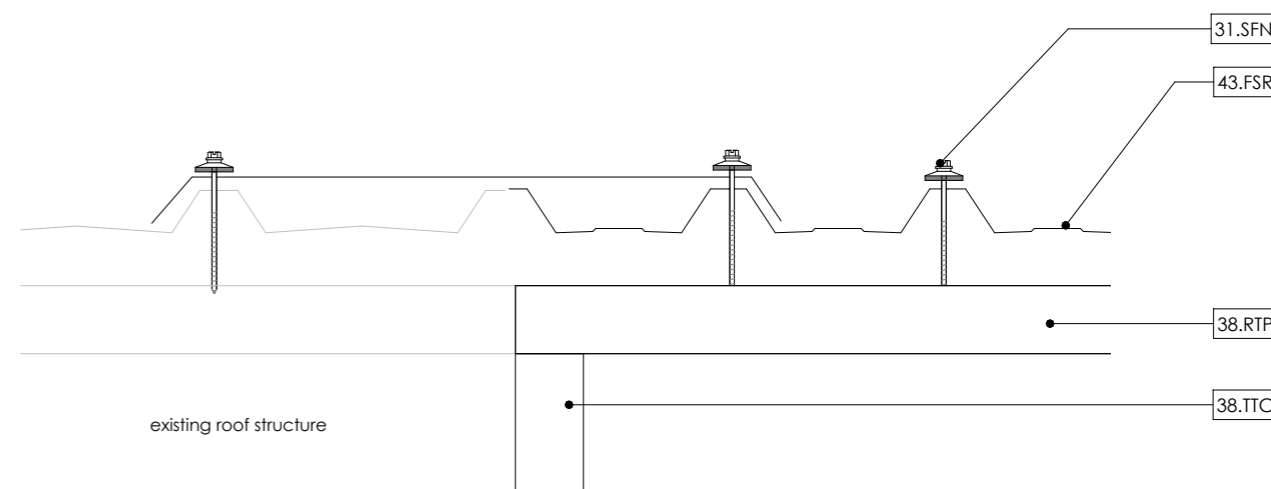

332 Roof Joint With Existing
A4.00 1 : 5 @ A3

Keynote Legend Per Page

Key Value	Keynote Text
31.RDN	65x2.8mm Round Drive ring shank nails for batten fixing
31.RIV	RIVET: Aluminium standard rivets.
31.SFN	SCREW: min. 12 gauge screw fixing w/ neoprene washer over EPDM washer where required to allow for expansion. 6T3 - Hit 2, Miss 2, Hit 1. 75mm nail.
38.ETE	EXTERNAL TIMBER FRAMING EXISTING: 90 x 45mm, H1.2 treated timber wall framing remain unchanged.
38.RTP	TIMBER PURLINS: 70x45mm SG8 H1.2 treated timber purlins with 900mm spacing, max fixed with 1/10g Self-drilling screw, 80mm long, at each rafter/truss.
42.AXO	AXON Panel: 9mm thick x 1200mm wide Axon Panel, over CLD cavity battens fixed to wall framing, over RAB board to new timber wall framing. To be installed in accordance with Axon Panel Technical Specification. Coat paint finish to match existing cladding, unless noted otherwise.
42.CCL	CAVITY CLOSER: Cavity closure strip Hardie uPVC vent strip 75mm min upstand with 1000mm ² of opening per lineal metre. Keep clear of debris.
42.SCB	CAVITY BATTEN: 70 x 19mm Hardie CLD Structural Cavity Batten installed in 20mm drained cavity fixing.
43.FSR	ROOFING: Freeman Six Rib Roofing 0.55 BMT Colorcote MagnaFlow pre-finished steel trapezoidal roofing. Colour match the existing.
43.JHS	JAMES HARDIE SOFFIT LINING: 6mm prefinished Villaboard Eaves soffit lining and pvc jointers with painted finish
43.SEA	BRANZ approved flexible sealant.
43.TAF	TYPICAL APRON FLASHING: 0.55mm BMT Colorcote MagnaFlow apron flashings complete with hem. 75mm min. cover to over flashing, 110mm total height. over flashing w/ 35mm min. clearance to apron flashing. refer to cladding notes for material type.
47.RAB	Rigid Air Barrier: James Hardie RAB Board 6mm.
47.SNF	SEAL: apply continuous 6mm bead of Seal n Flex-1 or Sikaflex 11FC adhesive sealant.
51.HGL	13mm GIB Standard interior wall lining, level 4 plaster and paint finish

General Notes:

1. This drawing shall be read in conjunction with all other drawings & specifications.
2. All work shall be strictly in accordance with the New Zealand Building Code, Local Territorial Authority Requirements, OSH Requirements & Regulations, and any other Statutory Requirements that may be applicable to this project.
3. All work shall be of best trade practice.
4. Do not scale from this drawing. Use only figured dimensions. The Contractor shall verify all dimensions on site, and report any discrepancies to the Architect before commencing work.

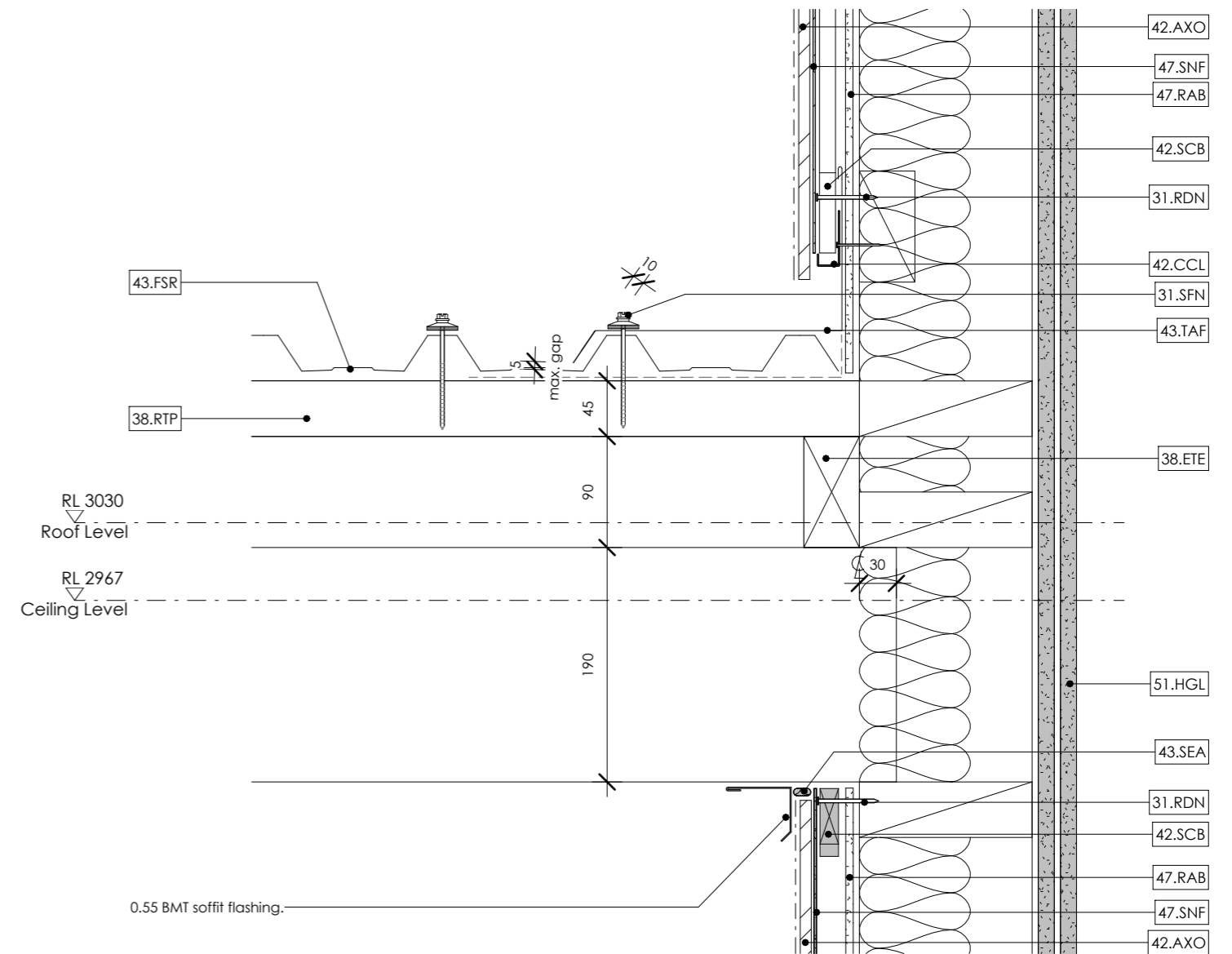
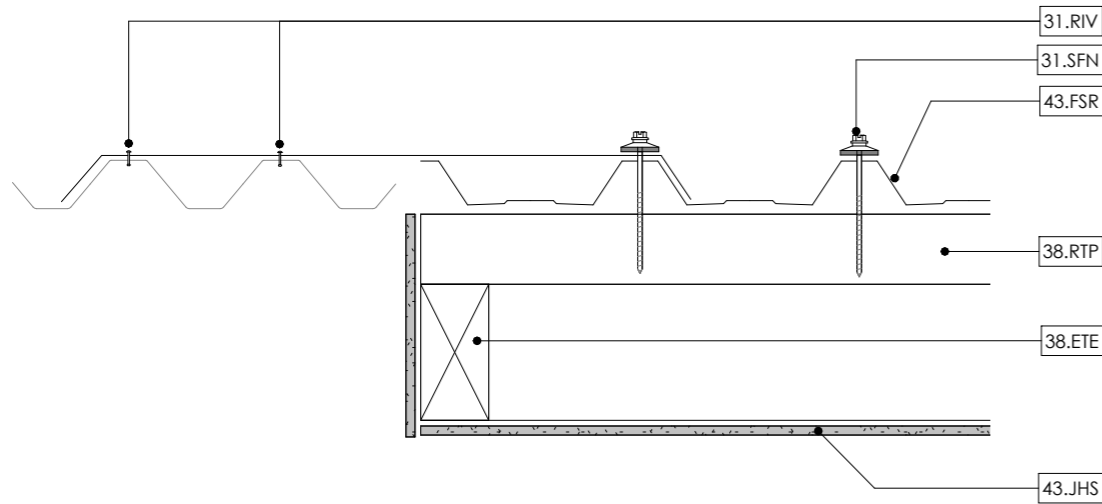

341 Trapezoidal Roof Join With Existing

1 : 5 @ A3

342 Varanda Rafter Joint With Wall

A4.00 1 : 5 @ A3

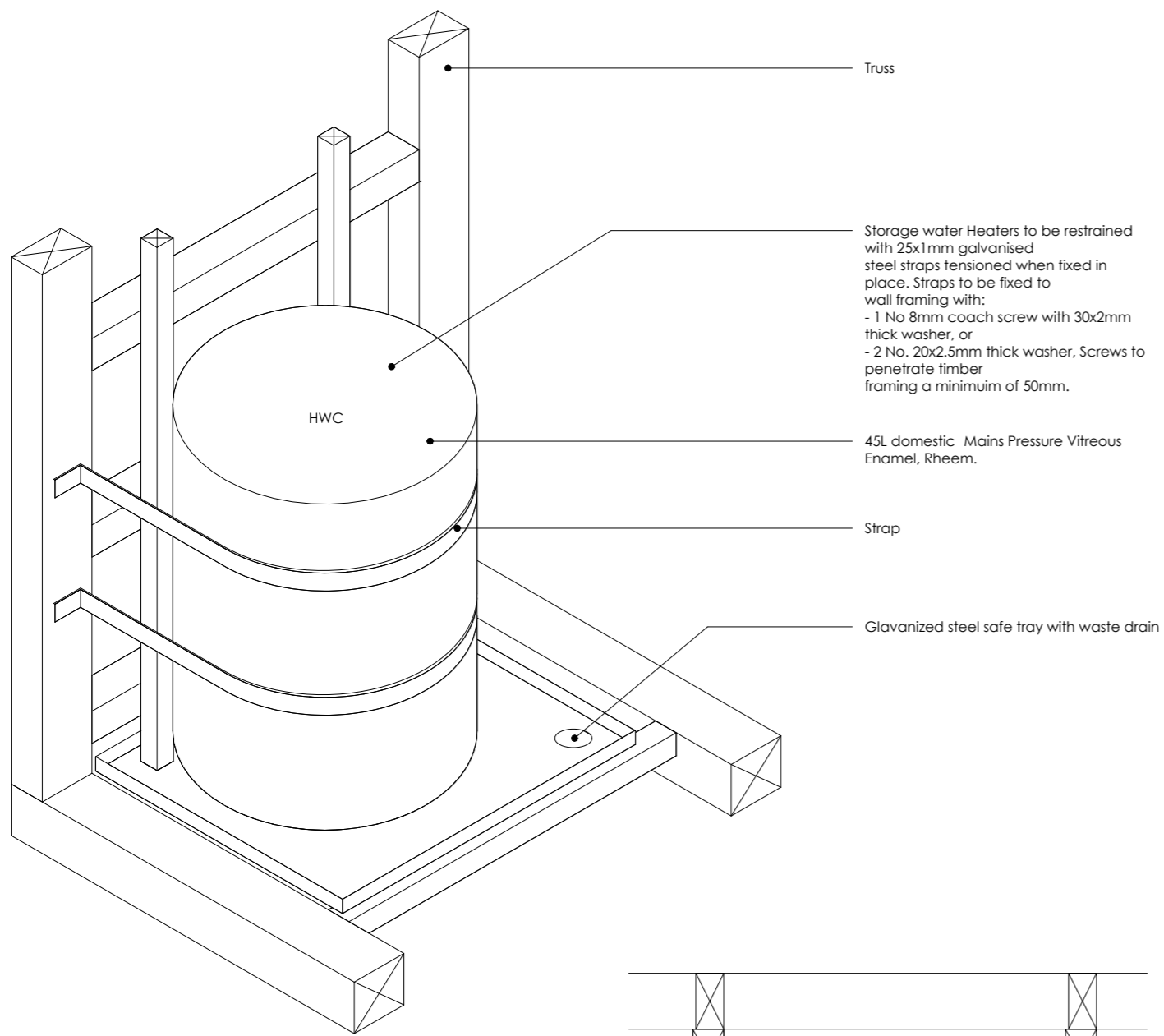

Ex50x50mm Vertical blocking full height of water heater. Fixed to wall framing with 1 No. 100x3.75mm nail at 600mm Maximum centres

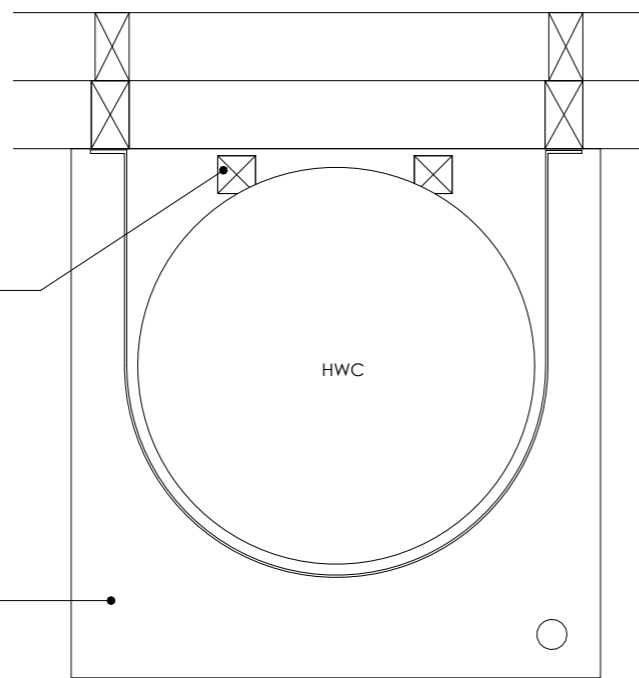

1 HWC
A5.00 1 : 10 @ A3

Keystone Legend Per Page	
Key Value	Keystone Text
42.AXO	AXON Panel: 9mm thick x 1200mm wide Axon Panel, over CLD cavity battens fixed to wall framing, over RAB board to new timber wall framing. To be installed in accordance with Axon Panel Technical Specification. Coat paint finish to match existing cladding, unless noted otherwise.
42.SCB	CAVITY BATTEN: 70 x 19mm Hardie CLD Structural Cavity Batten installed in 20mm drained cavity fixing.
43.DPC	DPC to provide separation of metal capping and timber.
43.SEA	BRANZ approved flexible sealant.
47.INW	Pink Batts wall insulation 90mm.
47.RAB	Rigid Air Barrier: James Hardie RAB Board 6mm.

- General Notes:**
1. This drawing shall be read in conjunction with all other drawings & specifications.
 2. All work shall be strictly in accordance with the New Zealand Building Code, Local Territorial Authority Requirements, OSH Requirements & Regulations, and any other Statutory Requirements that may be applicable to this project.
 3. All work shall be of best trade practice.
 4. Do not scale from this drawing. Use only figured dimensions. The Contractor shall verify all dimensions on site, and report any discrepancies to the Architect before commencing work.

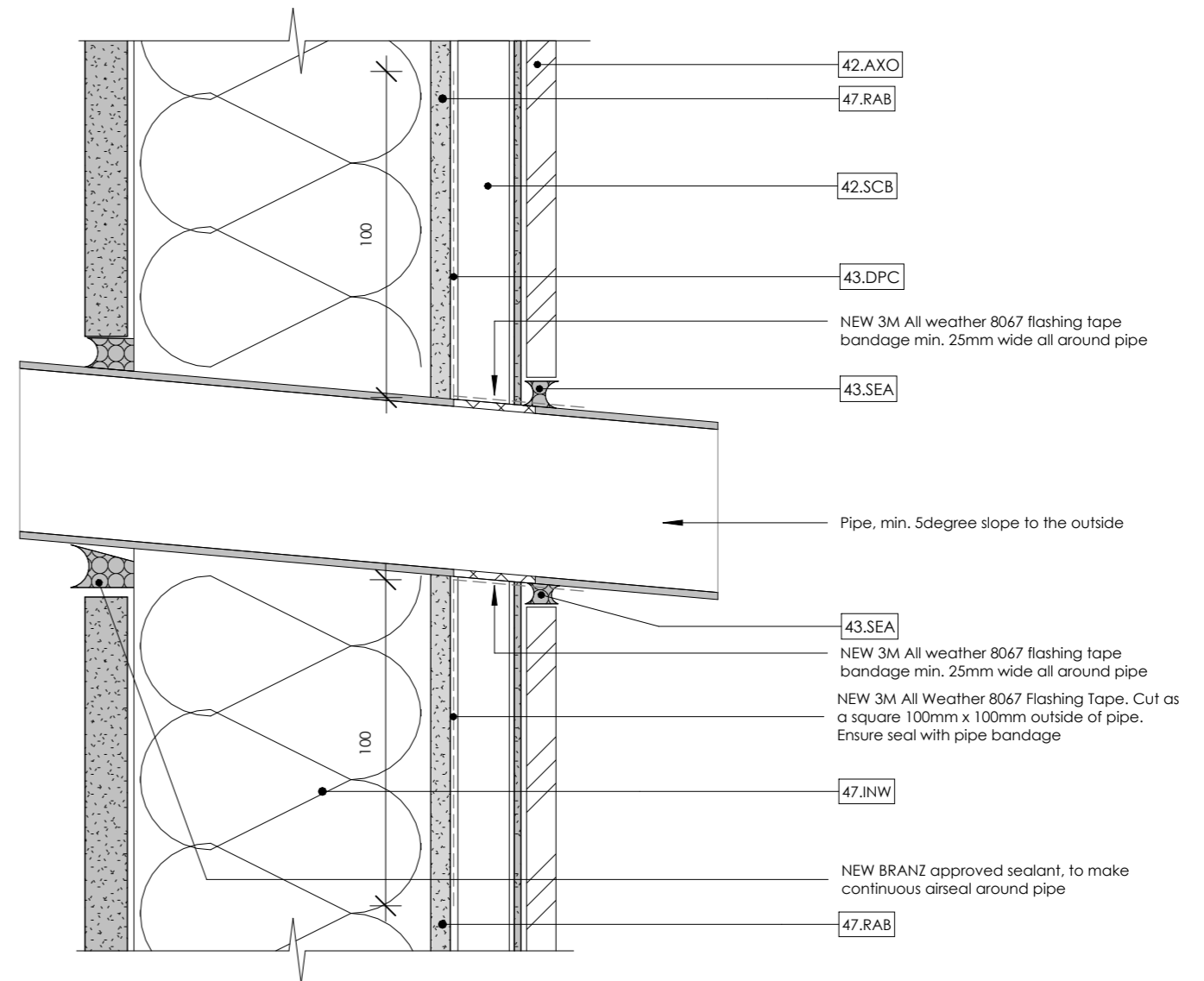

2 Pipe Penetration
1 : 2 @ A3



Copyright:
The copyright of this drawings remains the property of DLA Architects Limited and may only be used or re-used with DLA's prior written consent.

Project:
Clandeboye Bio Mass Control Room & Amenities

Client:
Fonterra Clandeboye

Drawing Title:
HWC and Pipe Penetration
CAD File:

REV.	DATE	REVISION DETAILS
1	28/08/24	Tender Issue
0	27/05/24	First Issue

Scale: As indicated @ A3	Date: 29/08/24	Drawn: MX
Job No: C919	Designed: MA	Checked: CG
Drawing No: A8.35	Revision No: 1	

- General Notes:**
1. This drawing shall be read in conjunction with all other drawings & specifications.
 2. All work shall be strictly in accordance with the New Zealand Building Code, Local Territorial Authority Requirements, OSH Requirements & Regulations, and any other Statutory Requirements that may be applicable to this project.
 3. All work shall be of best trade practice.
 4. Do not scale from this drawing. Use only figured dimensions. The Contractor shall verify all dimensions on site, and report any discrepancies to the Architect before commencing work.

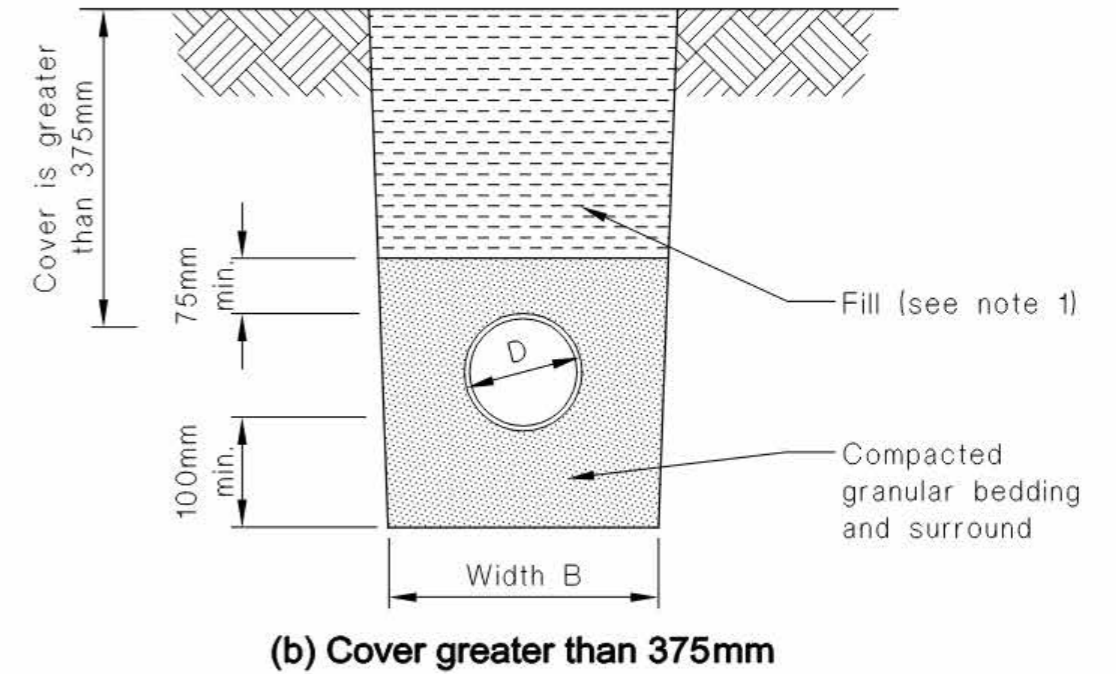
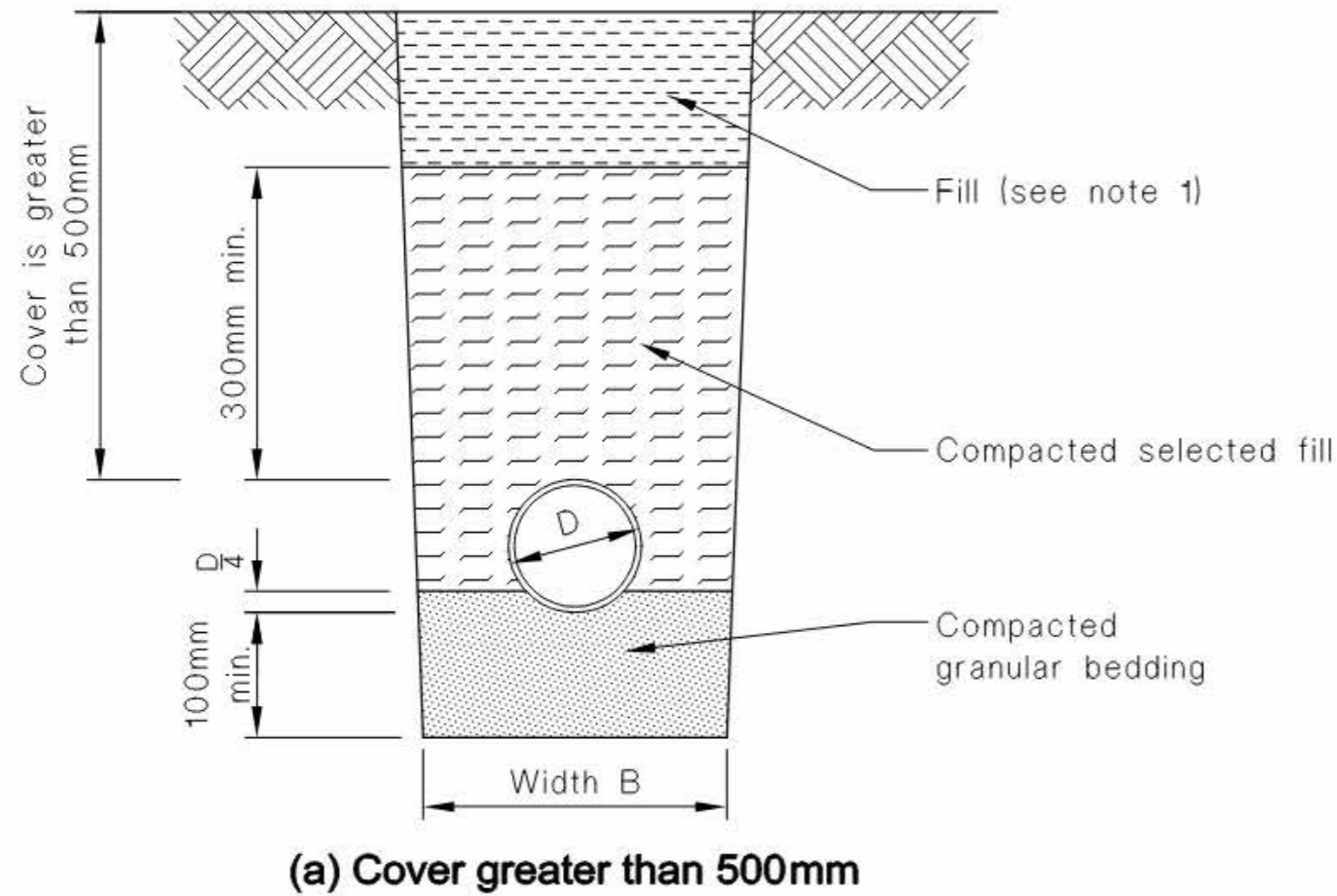

NOTE:
 1. Fill shall be:
 -Ordinary fill where drains are located below gardens and open country.
 -Compacted selected fill where the drains are located below residential driveways and similar areas subjected to light traffic.

Keynote Legend Per Page

Key Value	Keynote Text
38.ITF	INTERNAL TIMBER FRAMING: Construct with 90mm x 45mm SG8 h1.2 framing with studs @ 600mm crs to nzs3604:2011. Dwang at 800mmcrs. Dwang for all fittings, fixtures, linings, bracing panels & trims. DPC between bottom plate and conc. Slab.
51.HGA	13mm GIB Aqualine interior wall lining, level 4 plaster and paint finish
51.HGL	13mm GIB Standard interior wall lining, level 4 plaster and paint finish

General Notes:

1. This drawing shall be read in conjunction with all other drawings & specifications.
2. All work shall be strictly in accordance with the New Zealand Building Code, Local Territorial Authority Requirements, OSH Requirements & Regulations, and any other Statutory Requirements that may be applicable to this project.
3. All work shall be of best trade practice.
4. Do not scale from this drawing. Use only figured dimensions. The Contractor shall verify all dimensions on site, and report any discrepancies to the Architect before commencing work.

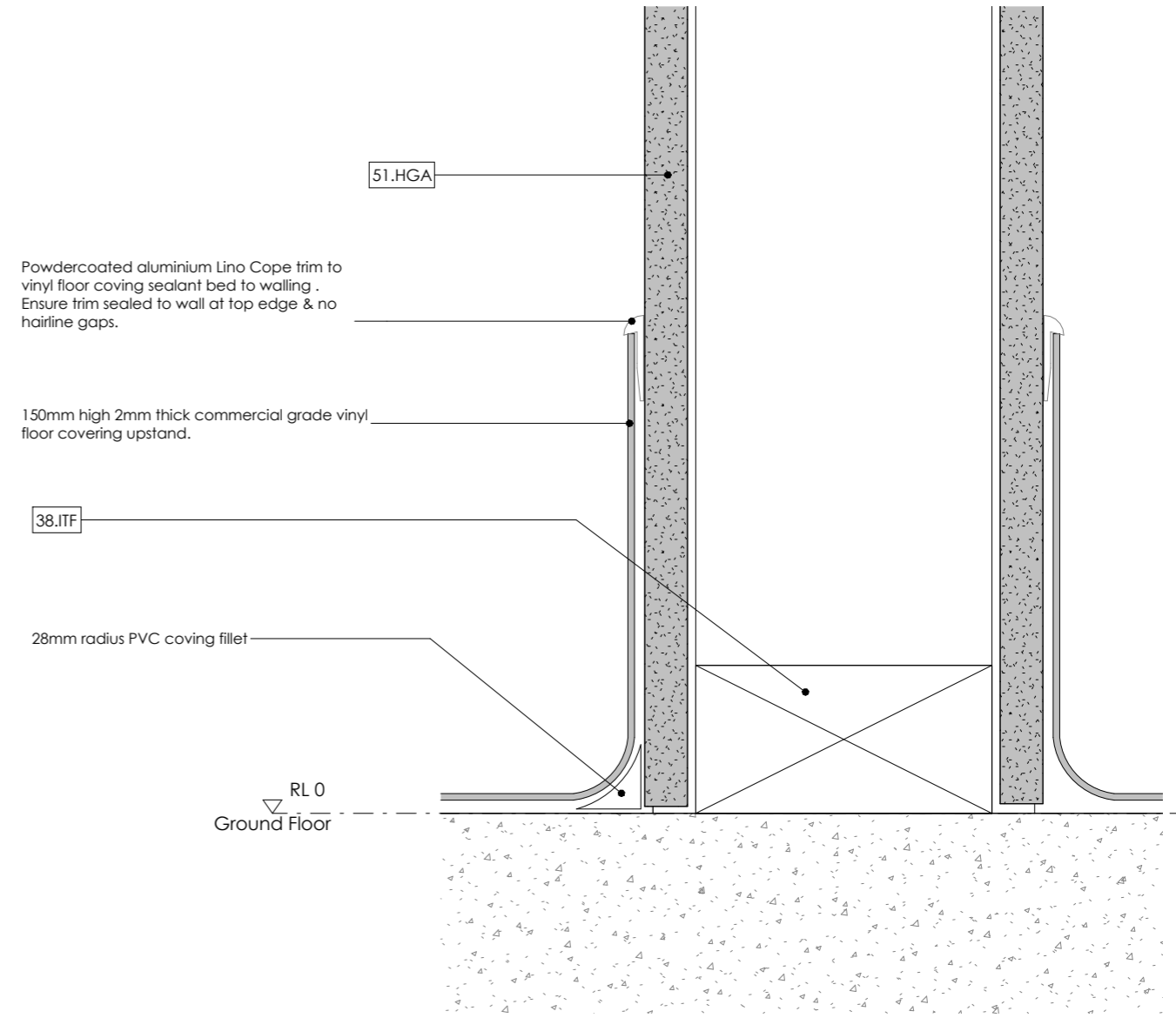
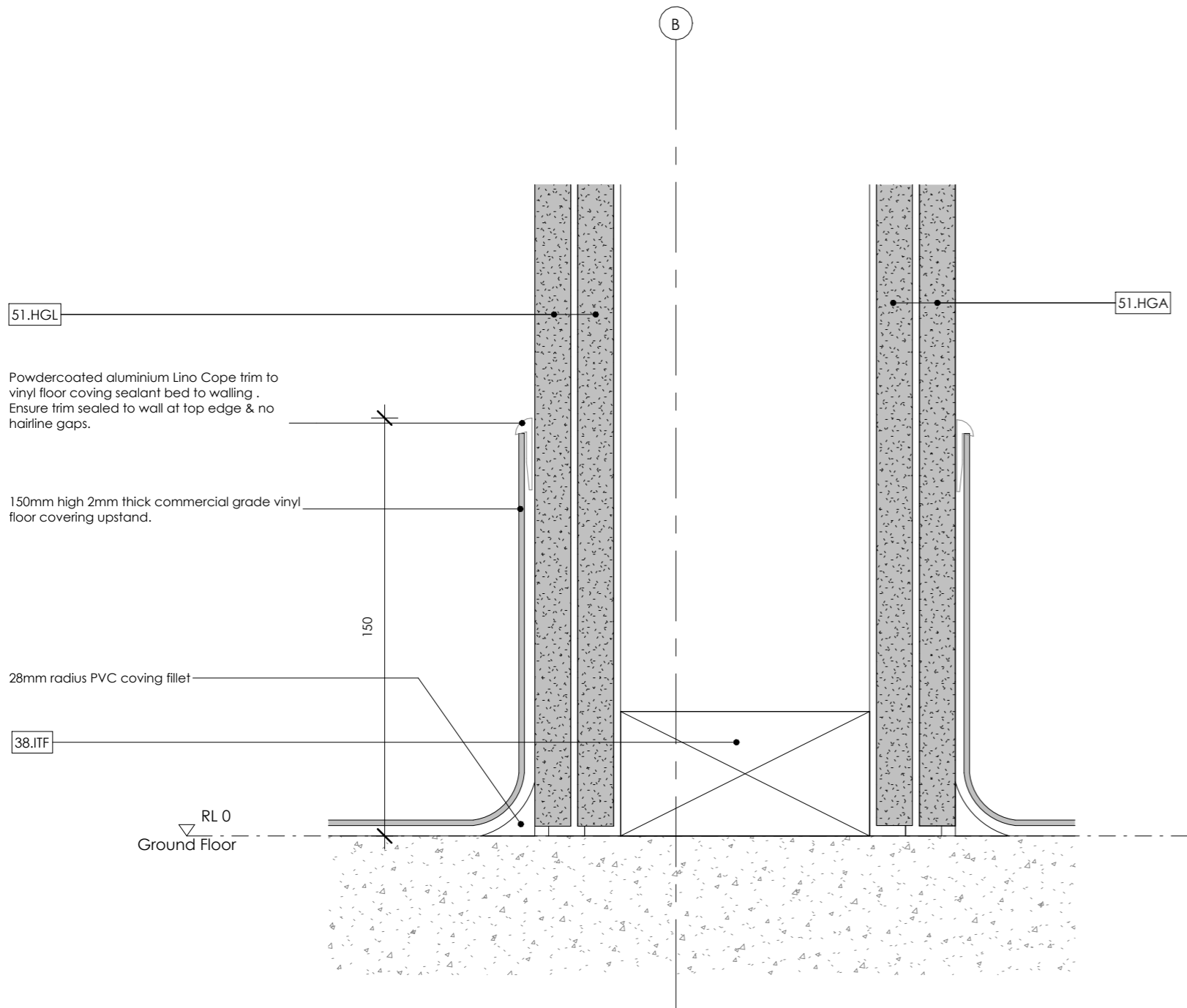

1 Vinyl Covered Upstand to ACC Toilet

A6.01 1 : 2 @ A3

2 Vinyl Detail Upstand in ACC and Wc.

A6.01 1 : 2 @ A3

- General Notes:**
1. This drawing shall be read in conjunction with all other drawings & specifications.
 2. All work shall be strictly in accordance with the New Zealand Building Code, Local Territorial Authority Requirements, OSH Requirements & Regulations, and any other Statutory Requirements that may be applicable to this project.
 3. All work shall be of best trade practice.
 4. Do not scale from this drawing. Use only figured dimensions. The Contractor shall verify all dimensions on site, and report any discrepancies to the Architect before commencing work.

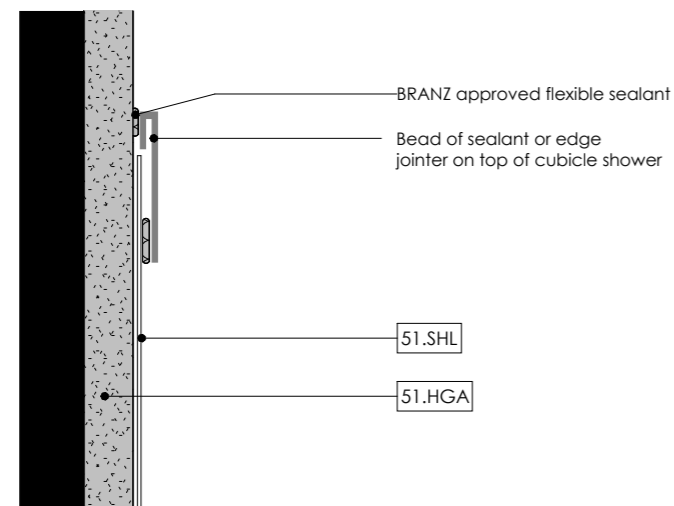

1 Cubicle Shower Top Seal
A5.02 1 : 2 @ A3

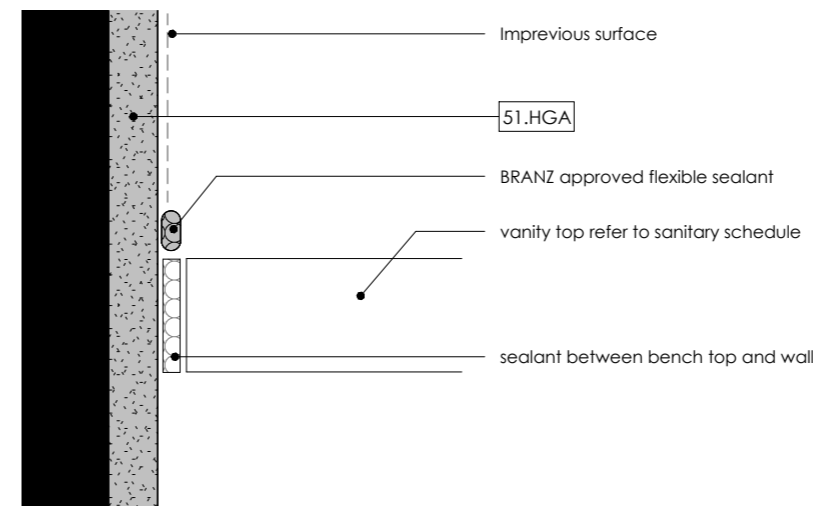

2 Vanity Top Join With Aqualine
A6.16 1 : 2 @ A3

Keynote Legend Per Page

Key Value	Keynote Text
43.SEA	BRANZ approved flexible sealant.
51.HGA	13mm GIB Aqualine interior wall lining, level 4 plaster and paint finish
51.SHL	Acrylic liner over unsealed GIB Aqualine.

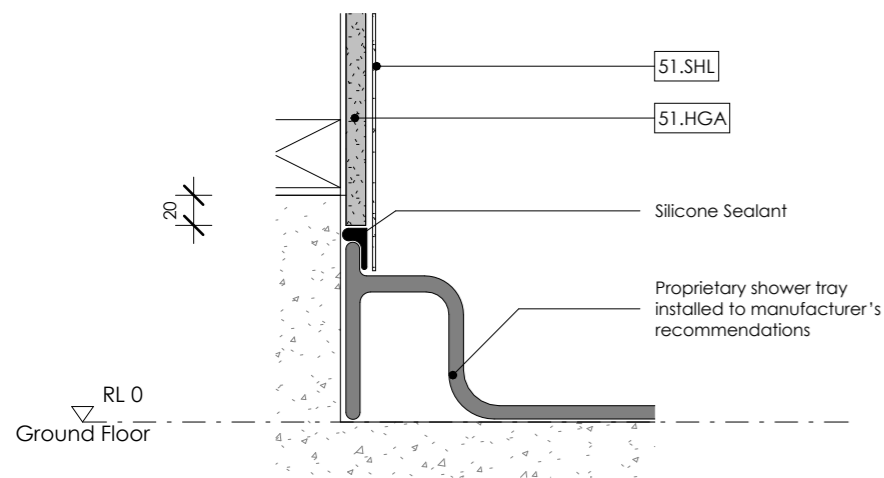

3 Shower Edge Detail
A5.02 1 : 5 @ A3

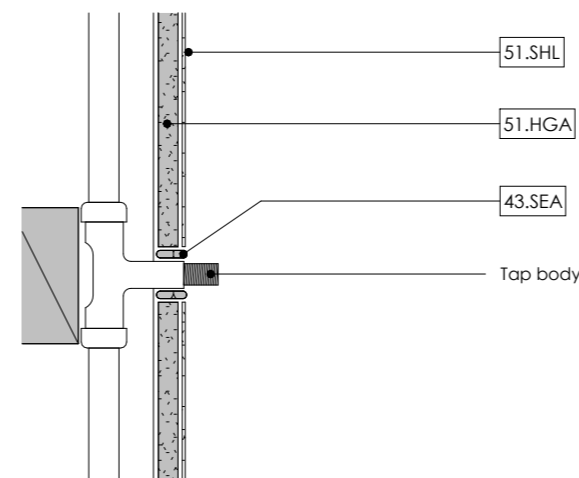

4 Sealing Semi Wet Area Penetration
A6.16 1 : 5 @ A3

REV.	DATE	REVISION DETAILS
1	28/08/24	Tender Issue
0	27/05/24	First Issue

Scale: As indicated @ A3	Date: 29/08/24	Drawn: MX
Job No: C919	Designed: MA	Checked: CG
Drawing No: A8.41	Revision No: 1	

General Notes:

1. This drawing shall be read in conjunction with all other drawings & specifications.
2. All work shall be strictly in accordance with the New Zealand Building Code, Local Territorial Authority Requirements, OSH Requirements & Regulations, and any other Statutory Requirements that may be applicable to this project.
3. All work shall be of best trade practice.
4. Do not scale from this drawing. Use only figured dimensions. The Contractor shall verify all dimensions on site, and report any discrepancies to the Architect before commencing work.

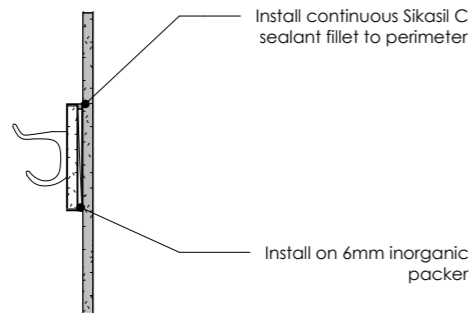

1 Coat Hooks Detail
A6.01 1 : 10 @ A3

For Overall Dimensions Refer to Coat Hook Rail Size Table below

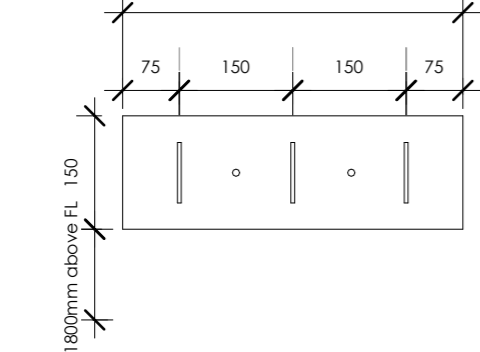

2 Coat Hooks Elevation
1 : 10 @ A3

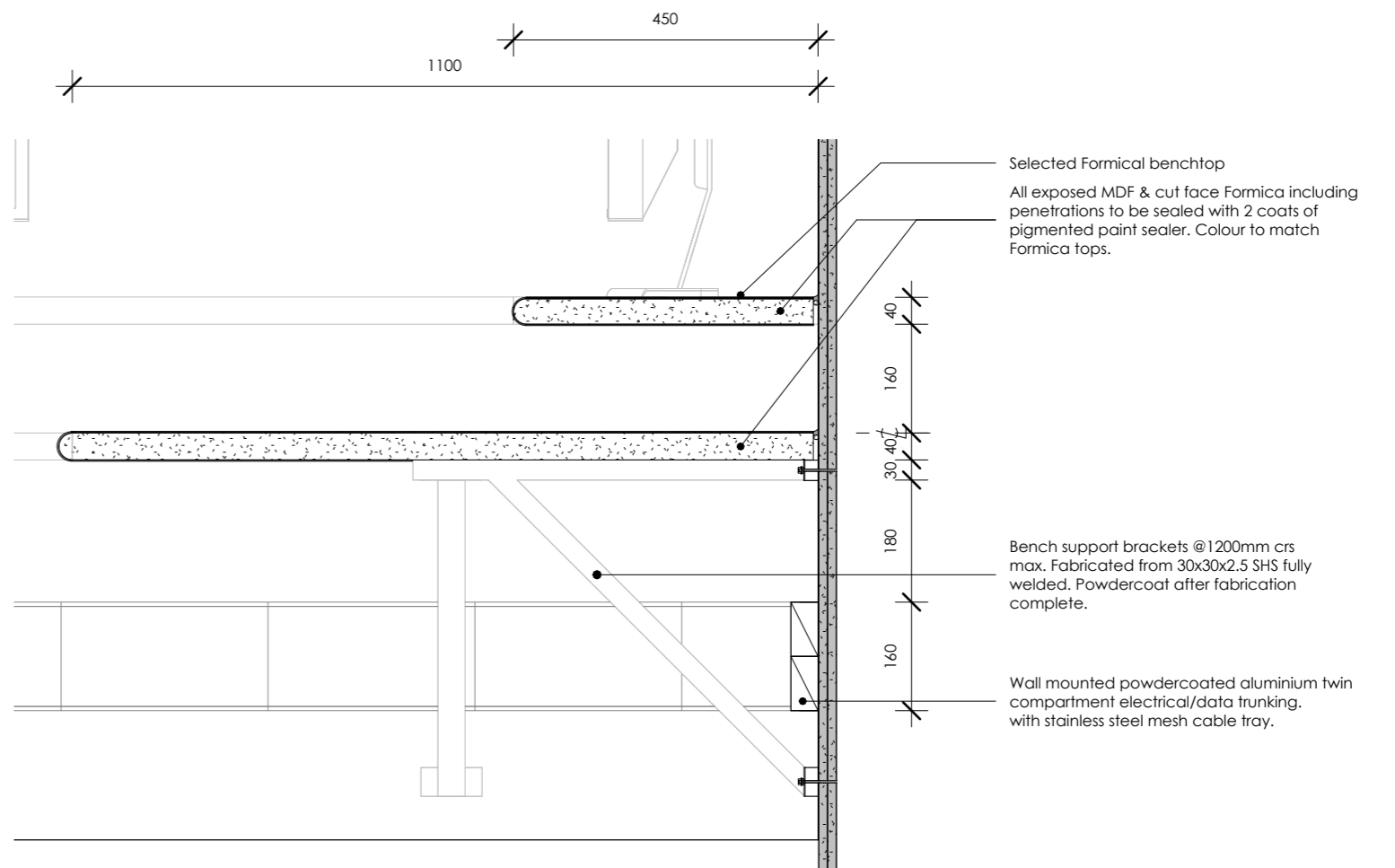

3 Control Room Benchtop Detail
A6.01 1 : 10 @ A3

Keynote Legend Per Page	
Key Value	Keynote Text
51.HGL	13mm GIB Standard interior wall lining, level 4 plaster and paint finish

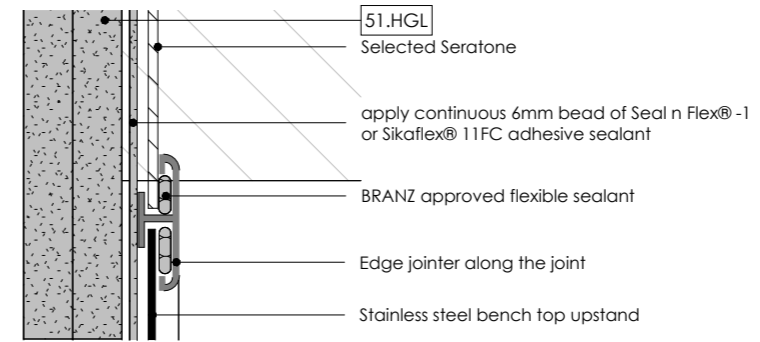
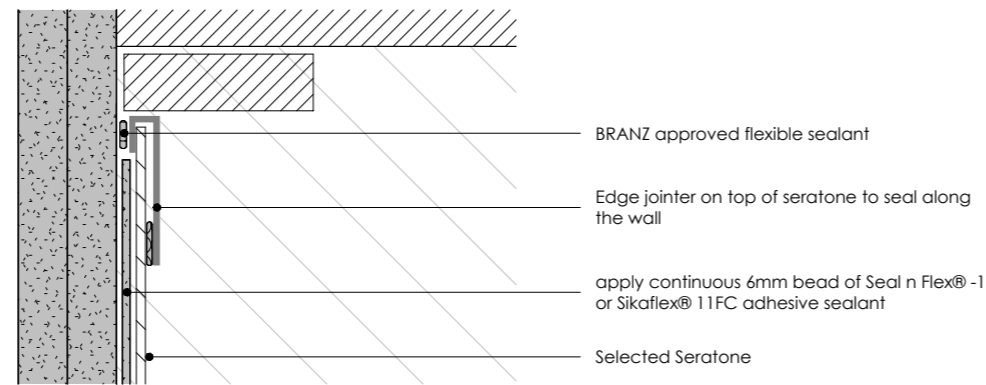

General Notes:

1. This drawing shall be read in conjunction with all other drawings & specifications.
2. All work shall be strictly in accordance with the New Zealand Building Code, Local Territorial Authority Requirements, OSH Requirements & Regulations, and any other Statutory Requirements that may be applicable to this project.
3. All work shall be of best trade practice.
4. Do not scale from this drawing. Use only figured dimensions. The Contractor shall verify all dimensions on site, and report any discrepancies to the Architect before commencing work.

a Seratone top seal
A9.02 1 : 2 @ A3

b Upstand joint with seratone
A9.02 1 : 2 @ A3

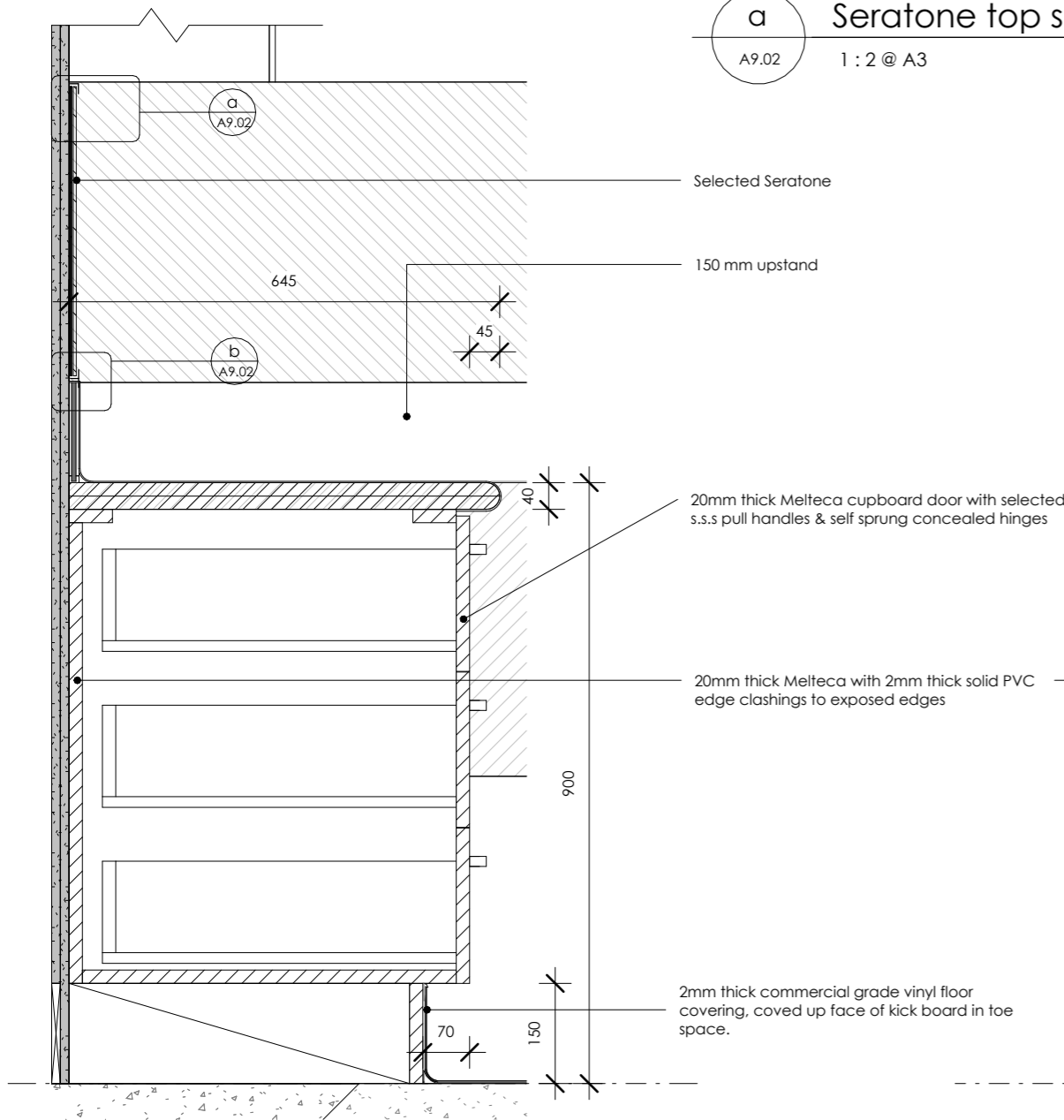

1 Permits Benchtop with cabinets
A6.01 1 : 10 @ A3

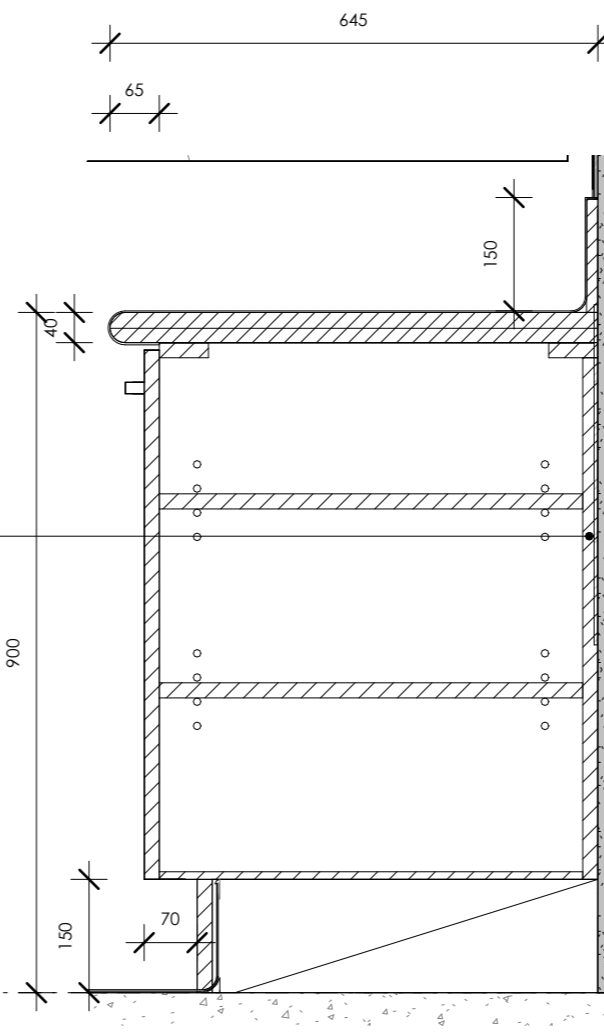

2 Permits Benchtop Cupboard Detail
A6.01 1 : 10 @ A3

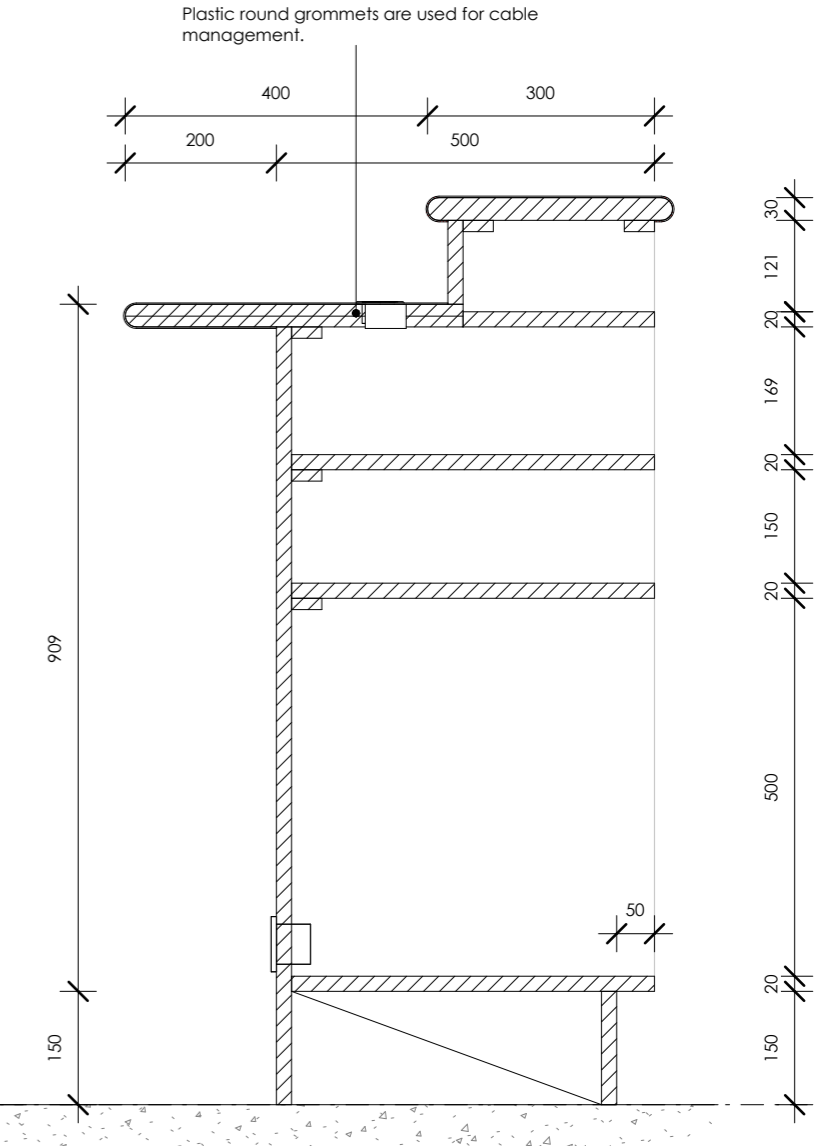

3 Permits Signin Table
A6.01 1 : 10 @ A3



Copyright:
The copyright of this drawings remains the property of DLA Architects Limited and may only be used or re-used with DLA's prior written consent.

Project:
Clandeboye Bio Mass Control Room & Amenities

Client:
Fonterra Clandeboye

Drawing Title:
Joinery Detail - Permits Detail
CAD File:

REV.	DATE	REVISION DETAILS
1	28/08/24	Tender Issue
0	27/05/24	First Issue

Scale: As indicated @ A3	Date: 29/08/24	Drawn: MX
Job No: C919	Designed: MA	Checked: CG
Drawing No: A9.02	Revision No: 1	

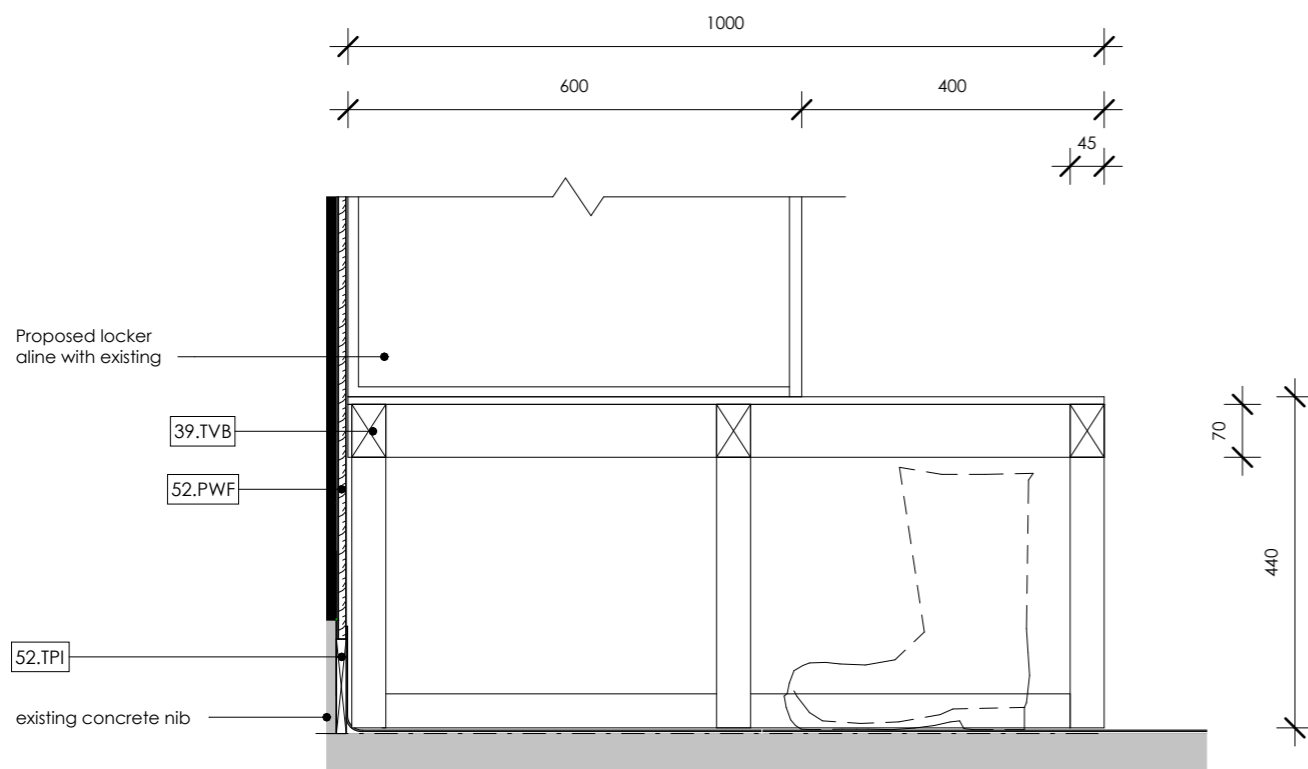

Keynote Legend Per Page	
Key Value	Keynote Text
39.TVB	BENCH: 70 x 45mm timber frame for Vinyl Bench.
52.PWF	FINISH: proposed plywood finish align with existing.
52.TPI	PACKER: Timber packer over DPC.

- General Notes:**
1. This drawing shall be read in conjunction with all other drawings & specifications.
 2. All work shall be strictly in accordance with the New Zealand Building Code, Local Territorial Authority Requirements, OSH Requirements & Regulations, and any other Statutory Requirements that may be applicable to this project.
 3. All work shall be of best trade practice.
 4. Do not scale from this drawing. Use only figured dimensions. The Contractor shall verify all dimensions on site, and report any discrepancies to the Architect before commencing work.

1 Locker With Vinyl Upstand
A6.01 1 : 10 @ A3

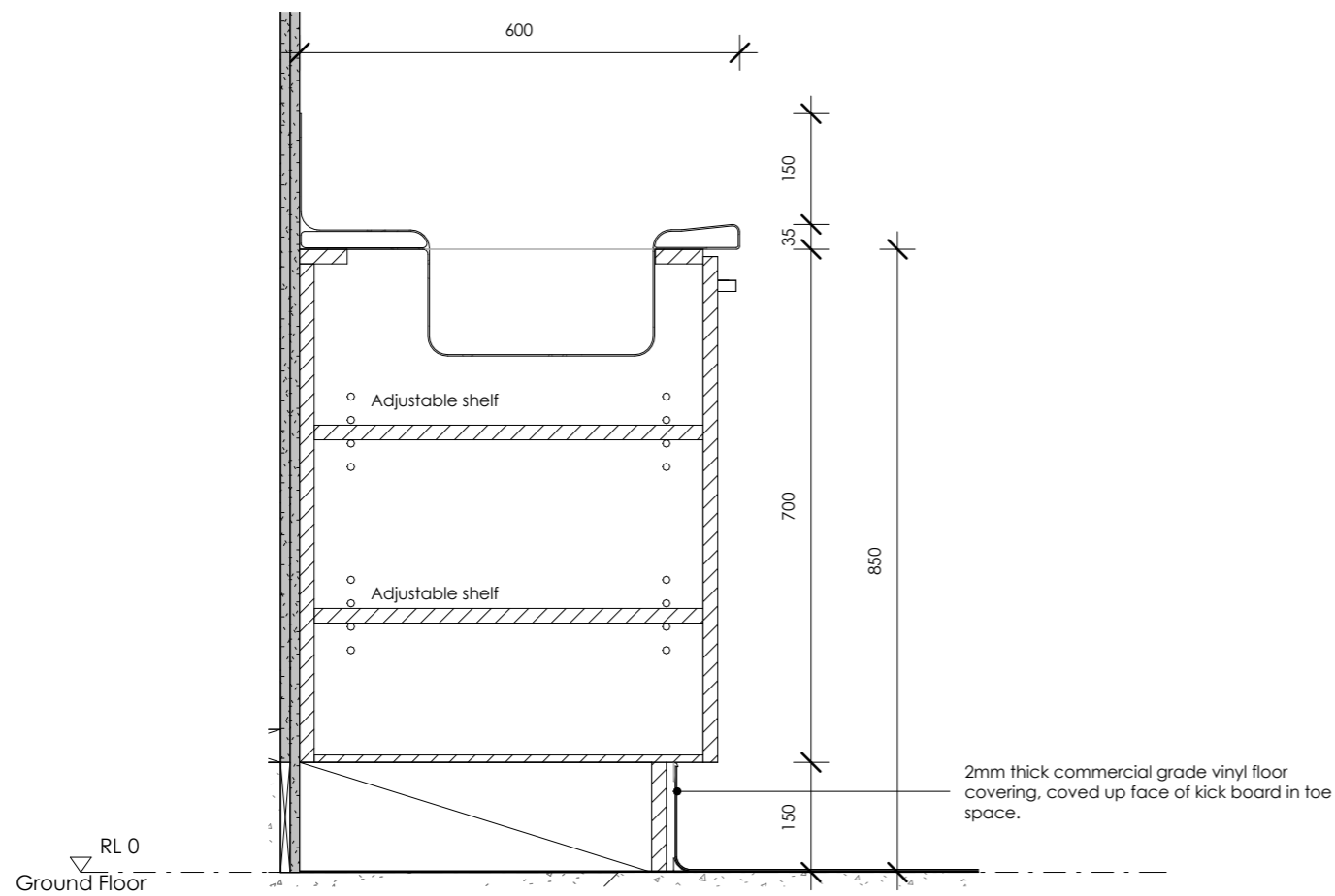

2 Lab Stainless Steel Benchtop
A6.01 1 : 10 @ A3

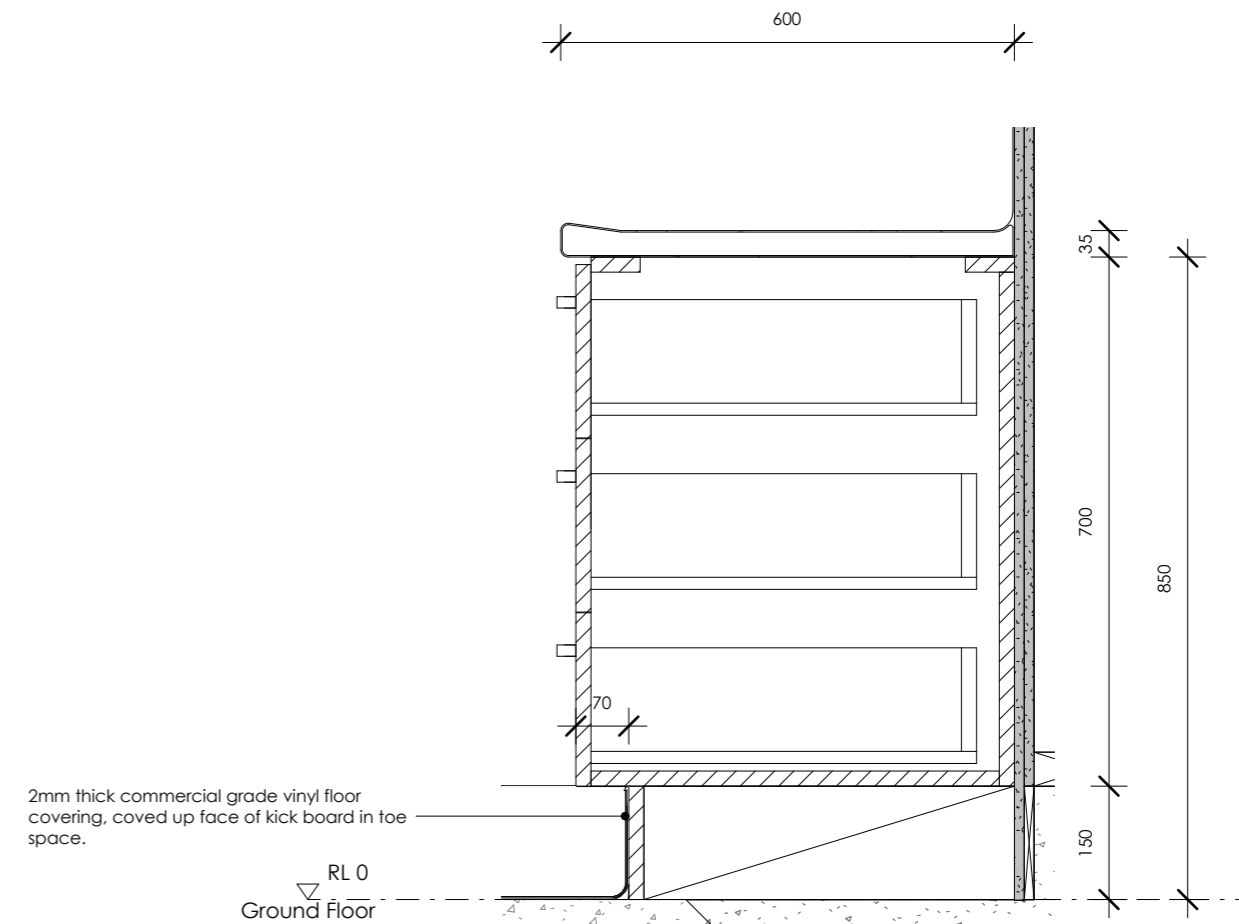

3 Lab Stainless Steel Benchtop 2
A6.01 1 : 10 @ A3



Copyright:
The copyright of this drawings remains the property of DLA Architects Limited and may only be used or re-used with DLA's prior written consent.

Project:
Clandeboyne Bio Mass Control Room & Amenities

Client:
Fonterra Clandeboyne

Drawing Title:
Joinery Detail - Lab And Locker Detail
CAD File:

REV.	DATE	REVISION DETAILS
1	28/08/24	Tender Issue
0	27/05/24	First Issue

Scale: 1 : 10 @ A3	Date: 29/08/24	Drawn: MX
Job No: C919	Designed: MA	Checked: CG
Drawing No: A9.03	Revision No: 1	

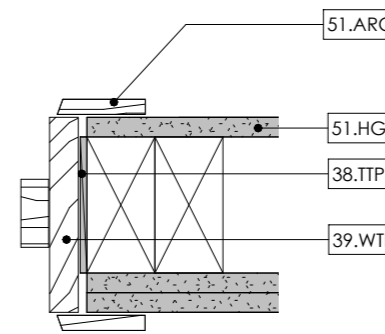
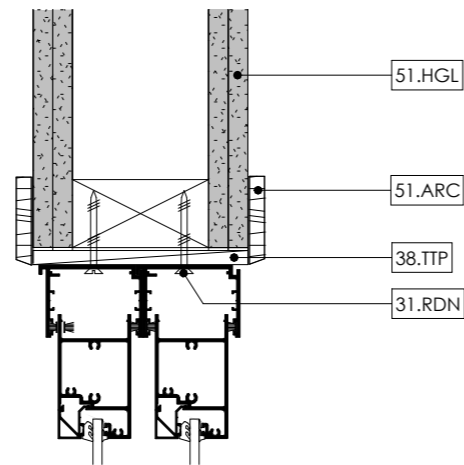
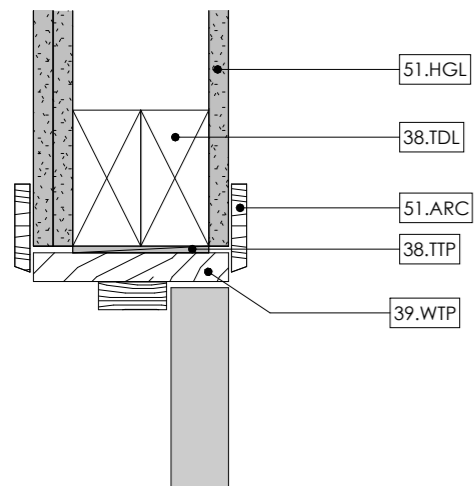

General Notes:

1. This drawing shall be read in conjunction with all other drawings & specifications.
2. All work shall be strictly in accordance with the New Zealand Building Code, Local Territorial Authority Requirements, OSH Requirements & Regulations, and any other Statutory Requirements that may be applicable to this project.
3. All work shall be of best trade practice.
4. Do not scale from this drawing. Use only figured dimensions. The Contractor shall verify all dimensions on site, and report any discrepancies to the Architect before commencing work.

Keynote Legend Per Page

Key Value	Keynote Text
31.RDN	65x2.8mm Round Drive ring shank nails for batten fixing
38.TDL	LINTEL: lintel refer to truss and lintel design schedule.
38.TTP	TIMBER PACKER.
39.WTP	25mm H3.1 pre-primed, pine timber, flush reveals with enamel painted finish.
51.ARC	ARCHITRAVE: 60x18mm timber architrave with enamel painted finish
51.HGL	13mm GIB Standard interior wall lining, level 4 plaster and paint finish

1 Interior Door Head Detail

A6.05 1 : 5 @ A3

2 Interior Sliding Door Head Detail

A6.02 1 : 5 @ A3

3 Interior Door Jamb Detail

A6.05 1 : 5 @ A3

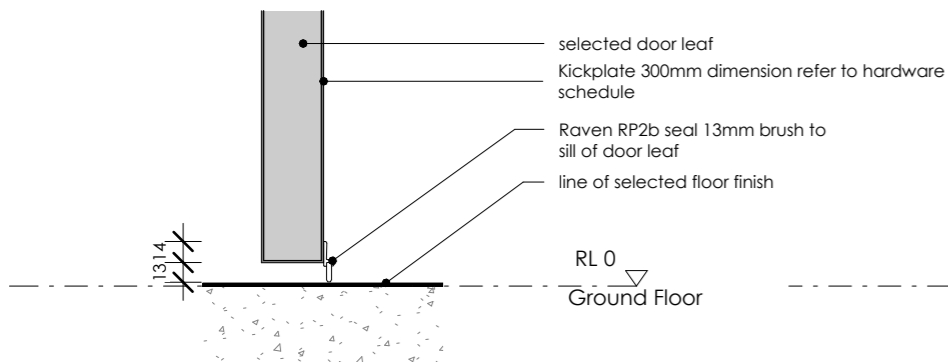

4 Interior Door Sill Detail

A6.05 1 : 5 @ A3

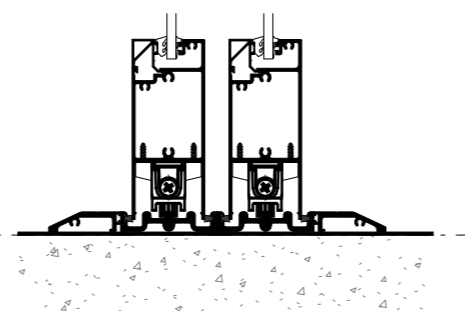

5 Interior Sliding Door Sill Detail

A6.02 1 : 5 @ A3

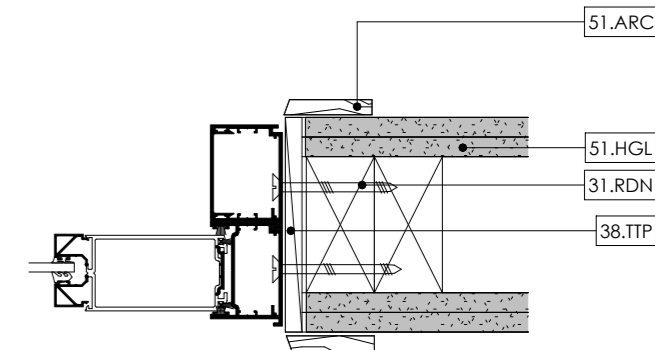
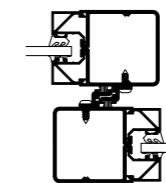
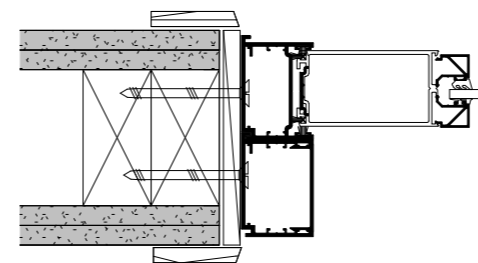

6 Interior Sliding Door Jamb Detail

A6.02 1 : 5 @ A3

General Notes:

1. This drawing shall be read in conjunction with all other drawings & specifications.
2. All work shall be strictly in accordance with the New Zealand Building Code, Local Territorial Authority Requirements, OSH Requirements & Regulations, and any other Statutory Requirements that may be applicable to this project.
3. All work shall be of best trade practice.
4. Do not scale from this drawing. Use only figured dimensions. The Contractor shall verify all dimensions on site, and report any discrepancies to the Architect before commencing work.

Keynote Legend Per Page	
Key Value	Keynote Text
31.RDN	65x2.8mm Round Drive ring shank nails for batten fixing
38.TTP	TIMBER PACKER.
39.WTP	25mm H3.1 pre-primed, pine timber, flush reveals with enamel painted finish.
51.ARC	ARCHITRAVE: 60x18mm timber architrave with enamel painted finish

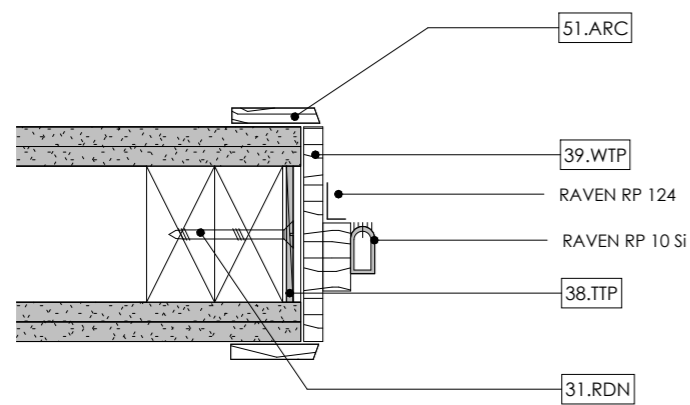

1 Office Door Jamb with Acoustic Sealing
A7.10 1 : 5 @ A3

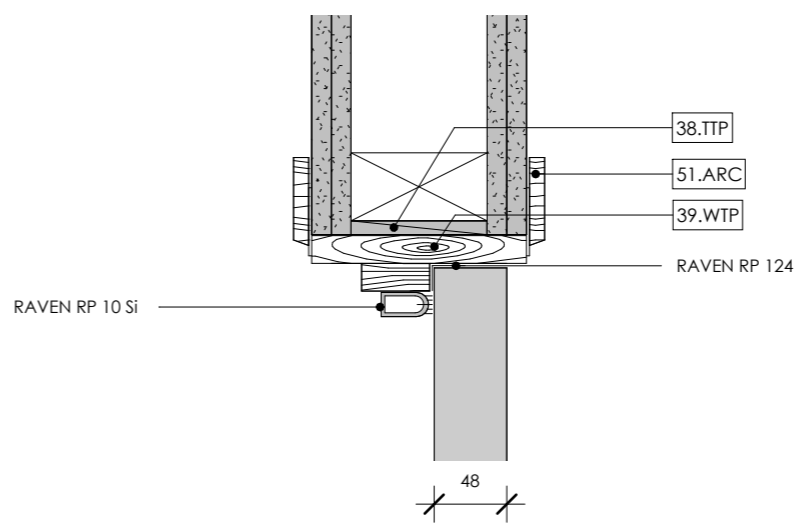

2 Office Door Head with Acoustic Sealing
A6.05 1 : 5 @ A3

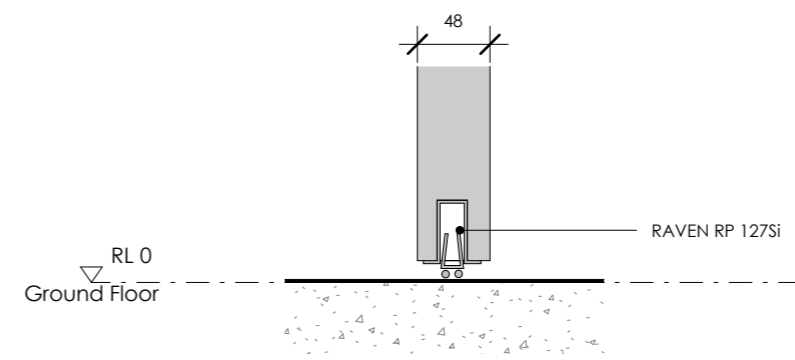

3 Office Door Sill with Acoustic Sealing
A6.05 1 : 5 @ A3



Copyright:
The copyright of this drawings remains the property of DLA Architects Limited and may only be used or re-used with DLA's prior written consent.

Project:
Clandeboye Bio Mass Control Room & Amenities

Client:
Fonterra Clandeboye

Drawing Title:
Interior Door with Raven Seal
CAD File:

REV.	DATE	REVISION DETAILS
1	28/08/24	Tender Issue
0	27/05/24	First Issue

Scale: 1 : 5 @ A3	Date: 29/08/24	Drawn: MX
Job No: C919	Designed: MA	Checked: CG
Drawing No: A9.05	Revision No: 1	

- General Notes:**
1. This drawing shall be read in conjunction with all other drawings & specifications.
 2. All work shall be strictly in accordance with the New Zealand Building Code, Local Territorial Authority Requirements, OSH Requirements & Regulations, and any other Statutory Requirements that may be applicable to this project.
 3. All work shall be of best trade practice.
 4. Do not scale from this drawing. Use only figured dimensions. The Contractor shall verify all dimensions on site, and report any discrepancies to the Architect before commencing work.

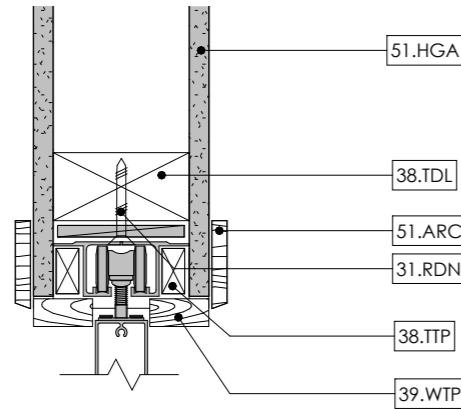

Keynote Legend Per Page	
Key Value	Keynote Text
31.RDN	65x2.8mm Round Drive ring shank nails for batten fixing
38.TDL	LINTEL: lintel refer to truss and lintel design schedule.
38.TTP	TIMBER PACKER.
39.WTP	25mm H3.1 pre-primed, pine timber, flush reveals with enamel painted finish.
51.ARC	ARCHITRAVE: 60x18mm timber architrave with enamel painted finish
51.HGA	13mm GIB Aqualine interior wall lining, level 4 plaster and paint finish
51.HGL	13mm GIB Standard interior wall lining, level 4 plaster and paint finish

1 ACC CS Sliding Door Head
A6.09 1 : 5 @ A3

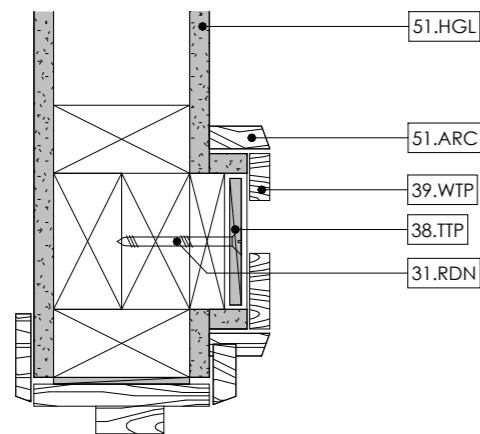

2 ACC CS Sliding Door Jamb
A7.10 1 : 5 @ A3

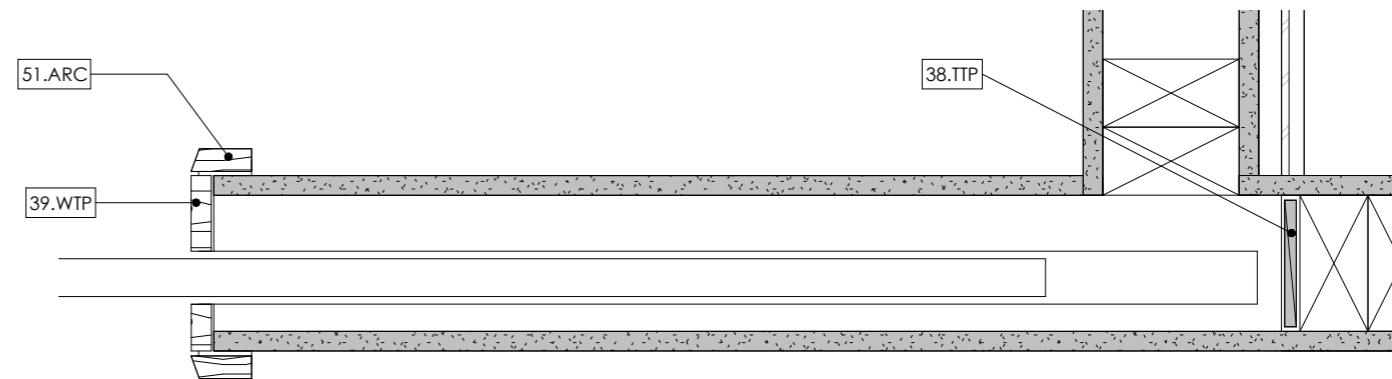

3 Cavity Slider
A7.10 1 : 5 @ A3